

| SPECIFICATION            | VALUE                |
|--------------------------|----------------------|
| NO. of PHASES            | 3                    |
| NO. of POLES             | 4                    |
| RATED VOLTAGE(V)         | 24                   |
| RATED CURRENT(A)         | 5±10%                |
| RATED POWER(W)           | 75                   |
| RATED SPEED(RPM)         | 4000±10%             |
| RATED TORQUE(mN.m)       | 179                  |
| NO LOAD CURRENT(A)       | 0.36                 |
| NO LOAD SPEED(RPM)       | 6200                 |
| SENSOR                   | HALL SENSOR          |
| INSULATION CLASS         | CLASS B              |
| INSULATION RESISTANCE    | 100MΩ MIN @ 500VDC   |
| DIELECTRIC STRENGTH TEST | 500VAC for 1 MINUTE  |
| BEARING TYPE             | NMB BALL BEARING, C3 |

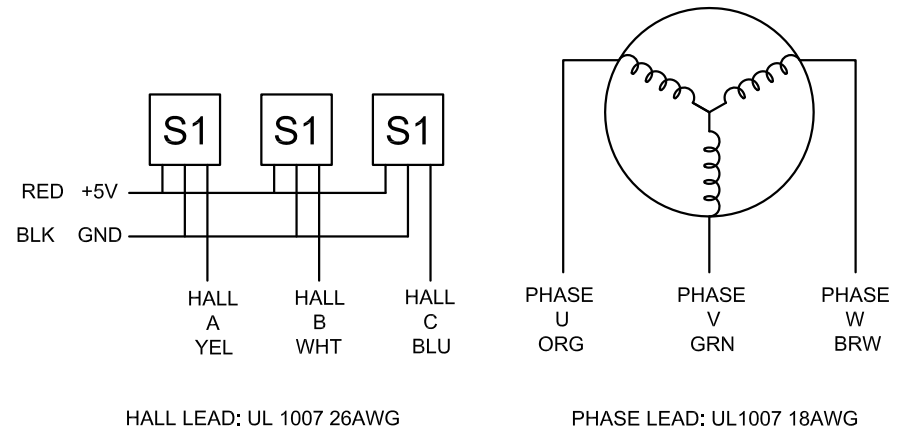

|       |           |      |
|-------|-----------|------|
| APVD  |           |      |
| CHKD  |           |      |
| 1.5:1 | DRN       |      |
| SCALE | SIGNATURE | DATE |

## BRUSHLESS DC MOTOR

42BLR83-24-01