

END COVER COLOR : BLACK

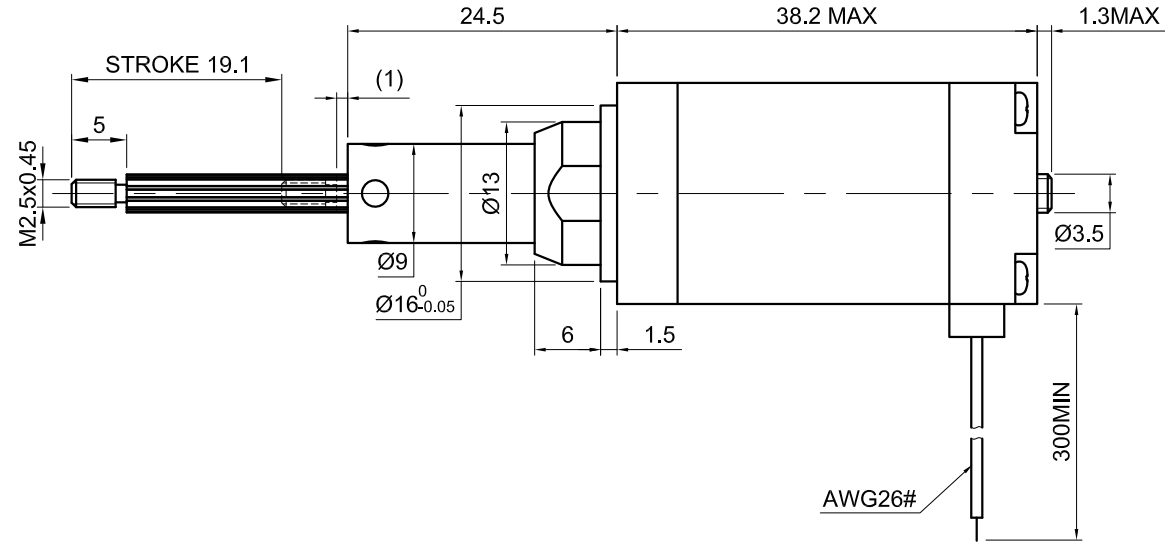
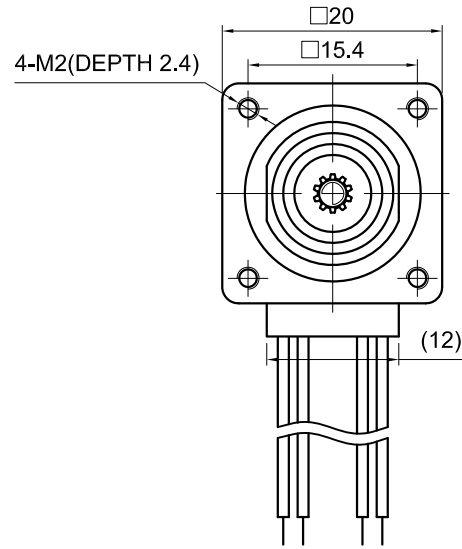

| SPECIFICATION | CONNECTION | BIPOLAR |
|-----------------------------|------------|------------|
| AMPS/PHASE | | 0.50 |
| RESISTANCE/PHASE(Ohms)@25°C | | 12.00±10% |
| INDUCTANCE/PHASE(mH)@1KHz | | 4.50±20% |
| HOLDING TORQUE(Nm)[lb-in] | | 0.02[0.18] |
| LEAD(mm) | | 2 |
| LINEAR TRAVEL/STEP(mm) | | 0.01 |
| STEP ANGLE(°) | | 1.80 |
| STEP ACCURACY(NON-ACCUM) | | ±5.00% |
| WEIGHT(Kg)[lb] | | — |

| |
|--|
| TEMPERATURE RISE:MAX.80°C (MOTOR STANDSTILL;FOR 2PHASE ENERGIZED) |
| AMBIENT TEMPERATURE -20°C~-+50°C[-4°F~-+122°F] |
| INSULATION RESISTANCE 100 Mohm (UNDER NORMAL TEMPERATURE AND HUMIDITY) |
| INSULATION CLASS B 130°C[266°F] |
| DIELECTRIC STRENGTH 500VAC FOR 1MIN.(BETWEEN THE MOTOR COILS AND THE MOTOR CASE) |

| TYPE OF CONNECTION (EXTERN) | | MOTOR | |
|-----------------------------|---------|---------|---------|
| PIN NO | BIPOLAR | LEADS | WINDING |
| 1 | A+ | RED | A+ |
| 2 | A- | RED/WHT | A- |
| 3 | B+ | GRN | B+ |
| 4 | B- | GRN/WHT | B- |

FULL STEP 2 PHASE-Ex. ,
WHEN FACING MOUNTING END (X)

| STEP | A+ | B+ | A- | B- | | CCW |
|------|----|----|----|----|--------|--------|
| 1 | + | + | - | - | ↓ ↑ | ↑ ↓ |
| 2 | - | + | + | - | | |
| 3 | - | - | + | + | | |
| 4 | + | - | - | + | | |

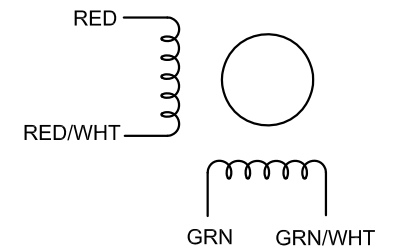

| | | |
|-------|-----------|-----------|
| APVD | | 8.10.2022 |
| CHKD | | |
| 1.5:1 | DRN | |
| SCALE | SIGNATURE | DATE |

STEPPER MOTOR

8C15S0504AC5-019RS