





E6 Series

Servo Driver with Motor User Manual



Safety precautions (please read carefully before use)





When receiving inspection, installation, wiring, operation, maintenance and inspection, you should pay attention to the following safety precautions at all times:



Regarding ignoring the contents of the manual and using this product incorrectly, the degree of harm and damage that may be caused is distinguished and explained as shown in the following table.







 Danger	This mark indicates the content of “ accidents that may cause injury or property damage”
 Notes	This mark indicates the content of “ accidents that may cause injury or property damage”



Use the following graphic signs to explain the matters that should be observed:

	This graphic shows the contents of the prohibited items.
	This graphic shows the "mandatory" content that must be implemented.

 Danger		
About installation and wiring		
	Never connect the motor directly to a commercial power source.	Otherwise, it may cause fire and malfunction.
	Do not place flammable materials around the motor and driver.	Otherwise, it may cause a fire accident.
	The drive must be protected by an outer box. When installing the protective outer box, the outer box wall, other Keep the distance specified in the instruction manual between the machine and the drive.	Otherwise, it may cause electric shock, fire, and malfunction
	It should be installed in a place with less dust and no contact with water, oil, etc.	Otherwise, it may cause a fire accident
	The motor and driver are installed on non-combustible materials such as metal.	Otherwise, it may cause electric shock.
	Be sure to have a professional electrician perform the wiring work.	Otherwise, it may cause electric shock.
	The FG terminal of the motor and driver must be grounded.	Otherwise, it may cause electric shock, injury, malfunction, or damage.
	The upper circuit breaker must be cut off in advance and the correct wiring must be performed.	Otherwise, it may cause a fire accident
	The cable should be properly connected and the energized parts must be insulated with insulators.	Otherwise, it may cause electric shock, fire, and malfunction.
About operation and operation		
	Do not touch the inside of the drive.	Otherwise, it may cause fire and malfunction.
	Do not let the cable be damaged, subjected to excessive external force, heavy pressure, or pinched.	Otherwise, it may cause a fire accident.
	Do not touch the rotating part of the motor during operation.	Otherwise, it may cause electric shock, fire, and malfunction
	Do not use it in a place with water, in an environment with corrosive, flammable gas, or near combustible materials.	Otherwise, it may cause a fire accident
	Do not use it in places subject to intense vibration or shock.	Otherwise, it may cause electric shock.
	Do not immerse the cable in oil and water for use.	Otherwise, it may cause electric shock.
	Do not connect and operate with wet hands.	Otherwise, it may cause electric shock, injury, malfunction, or damage.
	When using a motor with a keyway on the shaft end, do not touch the keyway with your bare hands.	Otherwise, it may cause a fire accident
	The temperature of the motor, driver, and radiator will rise, please do not touch them.	Otherwise, it may cause electric shock, fire, and malfunction.
	Do not use external power to drive the motor.	Otherwise, it may cause fire and malfunction.

Notes on other use		
	Be sure to confirm relevant safety after the earthquake.	Otherwise, it may cause a fire accident
	In order to prevent fires and personal accidents in the event of an earthquake, the installation and installation should be carried out properly.	Otherwise, it may cause electric shock, fire, and malfunction.
	An emergency stop circuit must be installed externally to ensure that the operation can be stopped and the power supply can be cut off in time in an emergency.	Otherwise, it may cause fire and malfunction.
About maintenance and inspection		
	The drive has dangerous high voltage parts. When wiring and inspection work, you must cut off the power supply and leave it to discharge (more than 5 minutes). And, it is absolutely not allowed to decompose it.	Otherwise, it may cause fire and malfunction.

 Notes		
About installation and wiring		
	The motor and driver must be combined as specified.	Otherwise, it may cause electric shock.
	Do not touch the connector terminals directly.	Otherwise, it may cause electric shock, injury, malfunction, or damage.
	Note that the vents must not be blocked or foreign objects enter.	Otherwise, it may cause a fire accident
	The test run must be carried out with the motor fixed and separated from other mechanical systems.	Otherwise, it may cause electric shock, fire, and malfunction.
	After confirming the action, install it on the mechanical system.	Otherwise, it may cause fire and malfunction.
	Observe the specified installation method and installation direction. Install properly according to the weight of the equipment and the rated output of the product.	Otherwise, it may cause electric shock.
About operation and operation		
	Do not stand on the product or place heavy objects on the product.	Otherwise, it may cause fire and malfunction.
	Prohibition of extreme gain adjustments and changes will cause unstable operation.	Otherwise, it may cause a fire accident.
	Do not use it in places exposed to direct sunlight.	Otherwise, it may cause electric shock, fire, and malfunction
	Do not subject the motor and motor shaft to strong impact.	Otherwise, it may cause a fire accident
	The function of the built-in brake of the motor is to keep the brake, and it is prohibited to use it for normal braking.	Otherwise, it may cause electric shock.
	When the power supply is restored after a power failure, it may start suddenly, so please do not approach the machine. Make sure to set up the machine to ensure personal safety even after restarting.	Otherwise, it may cause electric shock.
	Do not use faulty or damaged motors and drives.	Otherwise, it may cause electric shock, injury, malfunction, or damage.
	Please confirm whether the power supply specifications are normal.	Otherwise, it may cause a fire accident
	The holding brake is not a stopping device to ensure mechanical safety. Install a stop device to ensure safety on the machine side.	Otherwise, it may cause electric shock, fire, and malfunction.
	When alarming, remove the cause of the fault and ensure safety, then clear the alarm and restart.	Otherwise, it may cause fire and malfunction.
	The brake relay and the emergency stop circuit breaker relay must be connected in series.	Otherwise, it may cause a fire accident.
About maintenance and inspection		
	Do not store in places where rain or water splashes, or where there are toxic gases and liquids.	Otherwise, it may cause electric shock.
	When carrying, do not hold the cable or the motor shaft.	Otherwise, it may cause a fire accident
	Avoid falling or tipping when carrying or installing.	Otherwise, it may cause electric shock, fire, and malfunction.
	If long-term storage is required, please consult the contact method described in this manual.	Otherwise, it may cause fire and malfunction.

	Please keep it in a storage place that complies with the storage environment specified in this manual.	Otherwise, it may cause a fire accident.
Notes on other use		
	When disposing of batteries, please insulate them with tape, etc., and dispose of them in accordance with the regulations of the relevant authorities.	
	Please dispose of it as industrial waste.	
About maintenance and inspection		
	Do not carry out disassembly and repair work except our company.	Otherwise, it may cause fire and malfunction.
	Do not open and close the main circuit power switch frequently.	Otherwise, it may cause a fire accident.
	During power-on or within a certain period of time after the power is cut off, the motor, the radiator of the driver, and the regenerative resistor may be in a high temperature state. Do not touch it.	Otherwise, it may cause electric shock.
	When the drive fails, please cut off the control power supply and the main circuit power supply.	Otherwise, it may cause a fire accident.
	Be sure to cut off the main power supply when not in use for a long time.	Otherwise, it may cause electric shock.
About maintenance and inspection		
<p><Warranty Period></p> <p>◆ The warranty period of the product is 18 months from the month of manufacture of the company. However, for motors with brakes, the number of acceleration and deceleration of the shaft does not exceed the life span.</p>		
<p><Guaranteed Content></p> <p>◆ According to the normal use of this manual, within the warranty period, it will be repaired free of charge in case of failure. However, even if the following failure occurs during the warranty period, it is a paid repair.</p> <p>① Wrong use, and inappropriate repair and modification. ② When it is dropped after purchase, and the cause of damage during transportation. ③ The reason for using the product beyond the product specifications. ④ Fire, earthquake, thunderstorm, wind and flood, salt damage, abnormal voltage and other natural disasters. ⑤ When water, oil, metal pieces, or other foreign matter invades.</p> <p>◆ The scope of guarantee is the main body of the deliverable. If the damage is caused by the failure of the deliverable, it is judged to be outside the scope of compensation.</p>		

Content

Chapter 1 Product description and system selection.....	6
1.1 Model Type.....	6
1.2 Servo drive specifications.....	6
1.3 Servo System Wiring.....	9
1.4 Braking resistor related specifications.....	10
Chapter 2 Installation and Dimensions.....	11
2.1 Install environment.....	11
2.1.1 Install Site.....	11
2.1.2 Environment condition.....	11
2.1.3 Servo drive installation dimensions.....	11
2.1.4 Driver Installation	12
2.2 Servo Motor Installation.....	13
2.2.1 Install site.....	13
2.2.2 Environment condition	13
2.2.3 Notes.....	13
2.2.4 Wiring of the motor.....	15
Chapter 3 Instructions of Connection.....	16
3.1 The name of each part of the drive.....	16
3.2 I/O Terminal arrangement.....	17
3.2.1 CN1 Terminal arrangement description.....	17
3.2.2 CN2 Illustration of the terminal arrangement of the absolute encoder.....	17
3.2.3 CN3、CN4 Illustration of terminal arrangement.....	17
3.3 Models and specifications of main circuit connecting cables.....	18
3.3.1 Servo Drive Specification.....	18
3.3.2 Example of power supply wiring.....	18
3.3.3 Main circuit wiring precaution.....	19
3.3.4 Power line connection of servo drive and servo motor.....	20
3.4 Control signal terminal connection method.....	21
3.4.1 Position command input signal.....	21
3.4.2 Digital input and output signal.....	30
3.4.3 Encoder Frequency-Division Output Signal.....	34
3.4.4 Brake wiring.....	35
3.5 Comm. CN3/CN4 cable.....	37
3.5.1 CAN Communication networking connection.....	38
3.5.2 RS485 Comm. Connect way.....	39
3.5.3 Communication connection with PC (232 communication).....	41
3.6 Anti-interference countermeasures for electrical wiring.....	42
3.6.1 Examples of anti-interference wiring and grounding treatment.....	43
3.6.2 How to use the noise filter.....	43
3.7 Precautions for the use of cables.....	46
Chapter 4 Operation and Display.....	47
4.1 Location Mode Instructions.....	47
4.1.1 Location Mode Wiring.....	48
4.1.2 Position control mode related function code setting.....	49
4.2 Speed Mode Instructions.....	53
4.2.1 Speed Mode Overview.....	53
4.2.2 Speed Control Mode Block Diagram.....	54
4.2.3 Speed mode related function code setting.....	55

4.3 Instructions for use of torque mode.....	58
4.3.1 Torque Mode Wiring.....	59
4.3.2 Torque mode related function code setting.....	60
4.4 Instructions for using the absolute value system.....	63
4.4.1 Introduction.....	63
4.4.2 Related function code settings.....	63
4.4.3 Precautions for using the battery box of the absolute value system.....	68
4.5 Softlimit function.....	68
4.6 Pre-run Check.....	69
4.7 Load inertia identification and gain adjustment.....	70
4.7.1 Inertia identification.....	71
4.7.2 Manual gain adjustment.....	72
4.7.4 Notch filter.....	73
4.8 Background software.....	73
Chapter 5 Parameter summary.....	74
P00 Group Servo motor data sheet.....	74
P01 Group Servo Drive Datasheet.....	75
P02 Group Basic control parameters.....	75
P03 Group Terminal input parameters.....	77
P04 Group Terminal output parameters.....	79
P05 Group Position control parameters.....	81
P06 Group Speed control parameters.....	85
P07 Group Torque control parameters.....	85
P08 Group Gain class parameters.....	87
P09 Group Self-adjusting parameters.....	88
P0A Group Fault and Protection Parameters.....	09
P0B Group Monitoring parameters.....	91
P0C Group Communication parameters.....	93
P0D Group Auxiliary function parameters.....	94
P11 Group Multi-segment position function parameter.....	94
P12 Group Multi-segment speed parameter.....	99
P17 Group Virtual DIDO parameters.....	102
P30 Group Communication read servo-related variables Panel invisible.....	105
P31 Group Communication gives servo-related variables Panel invisible.....	105
DIDO Function definition.....	105
Chapter 6 MODBUS communication protocols.....	110
Chapter 7 Troubleshooting.....	113
7.1 Fault and warning handling at startup.....	113
7.1.3 Torque Control Mode.....	117
7.2 Runtime failures and warning handling.....	118
7.2.2 Trouble shooting method.....	121
7.2.3 How to deal with warnings.....	136

Chapter 1 Product description and system selection

1.1 Model Type

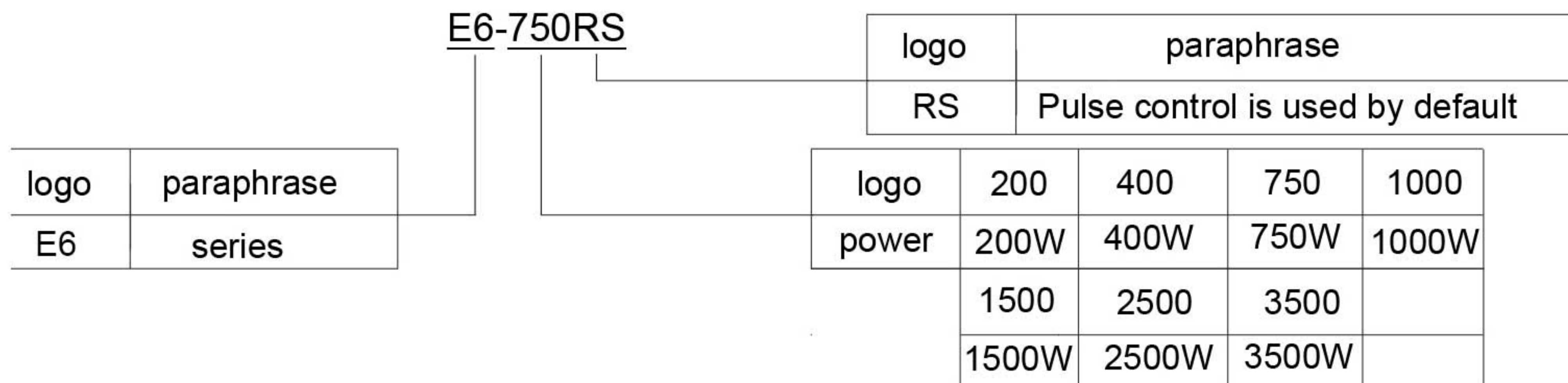

1.2 Servo drive specifications

Item		Specifications			
Model Type	E6 Series	E6-200RS	E6-400RS	E6-750RS	E6-1000RS
Outlook	L(mm)	51			
	H(mm)	171			
	D(mm)	154			
	Weight(kg)	0.9			
	Input Power	Single phase AC 200V-240V, -15%~10%, 50/60Hz			
Basic information	Temp °C	Use environment humidity	0~55°C		
		Storage environment humidity	-20~65°C		
	Humidity	Use environment humidity	20~85% RH below (No condensation)		
		Storage environment humidity	20~85% RH below (No condensation)		
	Use to preserve ambient air	indoor (no sunshine) 、 No corrosive gas, flammable gas, oil mist, dust			
	altitude	Below 1000m			
	vibration	5.8m/s ² (0.6G) below 10~60Hz (Can not be used continuously at resonance frequency)			
	Insulation withstand voltage	Basic—FG between AC1500V 1min			
Control way	Three-phase PWM converter sine wave drive				

Item		Specifications		
	Encoder feedback		1: 17bit (after adding a battery, it can be used as a multi-turn absolute encoder) 2: 23bit (after adding a battery, it can be used as a multi-turn absolute encoder)	
	Control signal	Input	9 inputs (DC24V optocoupler isolation) switch according to the control mode function	
		Output	5 output (DC24V optocoupler isolation, open collector output) switch according to the control mode function	
	Pulse signal	Input	2 inputs (optocouplerisolation, RS-422 differential, open collector output)	
		Output	4 outputs (A/B/Z phase RS-422 differential; Z phase open collector output)	
	Comm. function	RS232	For PC communication (for "Servostudio" connection)	
		RS-485	For upper remote control communication (1:n)	
		CAN	CANOPEN bus communication	
	Regeneration function		Optional regenerative resistor, external regenerative resistor. Pay attention to modify internal parameters	
	Control model		6 control modes: speed control, position control, torque control, torque/speed control, speed/position control, torque/position, torque/speed/position hybrid control	
Function	Control input		Alarm reset, proportional action switching, zero fixed function enable, forward drive prohibited, reverse drive prohibited, external torque limit for forward rotation, external torque limit for reverse rotation, forward jog, reverse jog, forward Reset switch, reverse reset switch, origin switch, emergency stop, servo enable, gain switch	
	Control output		Servo ready, motor rotating, zero speed signal, speed reached, position reached, positioning approach signal, torque limit, speed limit, brake output, warning, servo failure, alarm code (3-digit output)	
	P o s i t i o n	Pulse input	Maximum command pulse frequency	Differential input: high-speed maximum 4Mpps, pulse width cannot be less than 0.125μs The maximum low speed is 500Kpps, and the pulse width cannot be less than 1μs Open collector: maximum 200Kpps, pulse width cannot be less than 2.5μs
			Input pulse signal form	Differential input; open collector
			Input pulse signal method	Pulse + direction, right angle phase difference (Aphase + B phase), CW + CCW pulse
			Command pulse division/multiplication (Electronic gear ratio setting)	$0.1048576 < B/A < 419430.4$
			Command filter	Smoothing filter, FIR filter
	c o n t r o l	Pulse output	Output pulse form	PhaseA, Phase B: Differential output Z phase: differential output or open collector output
			Frequency division ratio	Arbitrary frequency division
			Outputpulse function	Encoder position pulse and position pulse command (can be set)

Item		Specifications
S p e e d	Control input	Servo ON, alarm reset, speed command reverse, zero speed clamp, internal command selection input 1, internal command selection input 2, internal command selection input 3, internal command selection input 4, forward rotation external torque limit input, reverse rotation External torque limit input, emergency stop
	Control output	Alarm status, servo preparation, brake release, torque limit output, speed limit output speed reached, speed consistent, motor rotation output, zero-speed signal output
c o n t r o l	Control input	Servo ON, alarm reset, torque command reverse, zero speed clamp
	Control output	Alarm status, servo preparation, brake release, torque limit, speed limit output, emergency stop
	Torque command input	(Factory default setting, the range can be set by function code)
	Speed limit function	Positive and negative internal speed limit P03.27, P03.28
Torque Control	Speed observer function	YES
	Damping control function	YES
	Adaptive notch filter	YES
	Automatic adjustment function	YES
	Encoder output frequency division	YES
	Internal location planning function	YES
	Adjustment/ function setting	Use the host computer setting software "Servostudio" to adjust
	Protection	Over voltage, abnormal power supply, overcurrent, overload, abnormal encoder, overspeed, excessive position deviation, abnormal parameters, etc.
Common	Control input	Servo ON, alarm reset, torque command reverse, zero speed clamp
	Control output	Alarm status, servo preparation, brake release, torque limit, speed limit output, emergency stop
	Torque command input	(Factory default setting, the range can be set by function code)
	Speed limit function	Positive and negative internal speed limit P03.27, P03.28
	Speed observer function	YES
	Damping control function	YES
	Adaptive notch filter	YES
	Automatic adjustment function	YES

1.3 Servo System Wiring

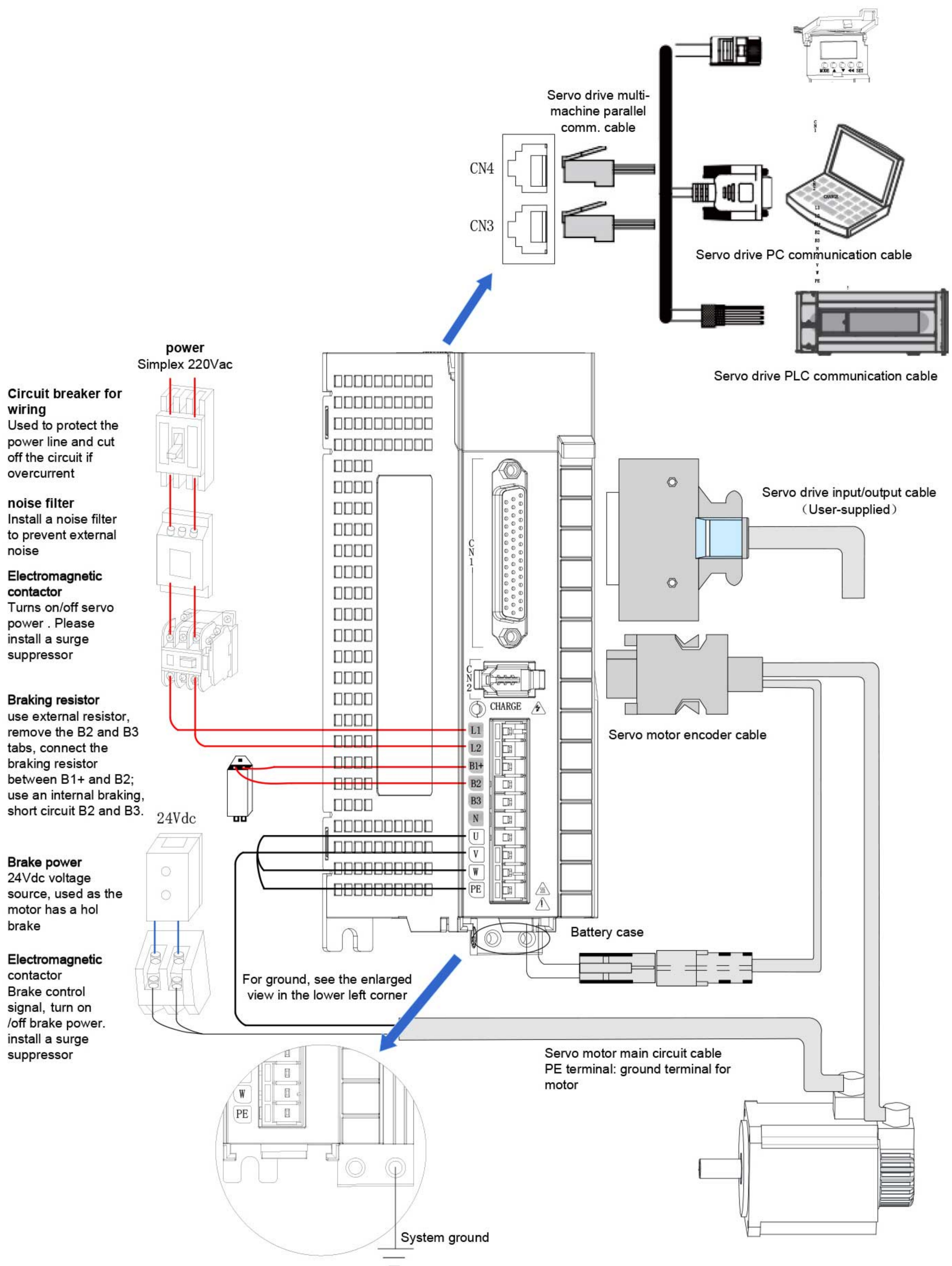

Please pay attention to the power supply capacity when connecting external control power supply or 24Vdc power supply, especially when supplying power to several drives or multiple brakes at the same time, insufficient power supply capacity will lead to insufficient supply current and failure of the drive or the brake. The braking power supply is a 24V DC voltage source. The power should refer to the motor model and meet the braking power requirements. System wiring precautions:

1. When connecting an external braking resistor, please remove the short-circuit wire between terminals B2 and B3 of the servo drive before connecting. Pay attention to modify the internal parameters.
2. CN3 and CN4 define exactly the same communication interface for the two pins, which can be used arbitrarily between the two.
3. In single-phase 220V wiring, the main circuit terminals are L1 and L2, and the reserved terminals should not be connected.

1.4 Braking resistor related specifications

Model Type		Built-in braking resistor specifications		Min. Allowed Resistance (Ω)	Max. Braking Energy Absorbed by Capacitor (J)
		Resistance (Ω)	Power(W)		
Single phase 220V	E6-200RS	-	-	50	9
	E6-200RS	-	-	45	18
	E6-750RS	50	50	40	26
	E6-1000RS	50	50	40	26

Note: E6-200RS and E6-400RS models have no built-in braking resistor. If you need to use it, please configure the external braking resistor by yourself. Please consult our technical support for the power selection of the external braking resistor.

2.1 Install environment

2.1.1 Install Site

- ① Install in a place that will not be directly exposed to sunlight. ② The driver must be installed in the control box
- ③ Install it in a place where it will not be immersed by water or oil (cutting oil, oil mist) and without moisture.
- ④ Keep away from corrosive atmospheres such as explosive and flammable gas, sulfide gas, chlorinated gas, ammonia, etc., acid/alkali and salt.
- ⑤ A place that will not be disturbed by dust, iron powder, cutting powder, etc.
- ⑥ Keep away from high temperature places, places with continuous vibration and excessive shock.

2.1.2 Environment condition

Figure 2-1 Drive install condition

Item	Description
Use ambient humidity	0~55°C (45°C~55°C, The average load rate should not exceed 80%)
Use ambient humidity	<90%RH
Storage temp.	-20~85°C
Storage temp.	90%RH below
Shock	4.9m/s ² below
Impact	19.6m/s ² below
protect level	IP20
Altitude	Below 1000m normal use, 1000m~2000m please lower power

2.1.3 Servo drive installation dimensions

E6-200RS, E6-400RS, E6-750RS, E6-1000RS (Unit:mm)

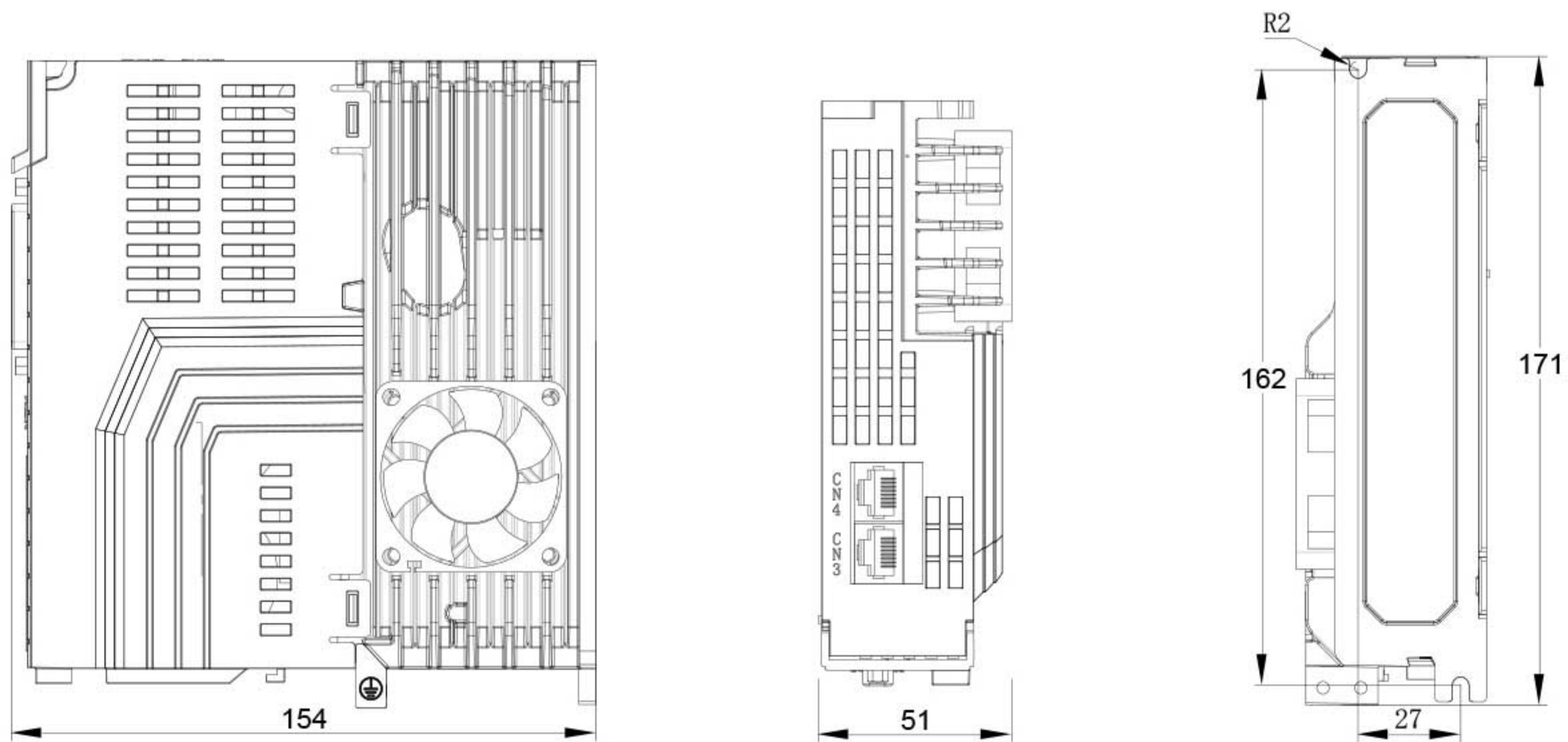

2.1.4 Drive Installation

direction and interval

When setting up the drive, in order to ensure the heat dissipation and heat convection in the protection box or the control box, sufficient space should be left around.

For the driver, install it in the vertical direction. When installing the driver, please use two M4 screws to fix it.

When installed in a sealed box such as a control box, in order to ensure that the surrounding

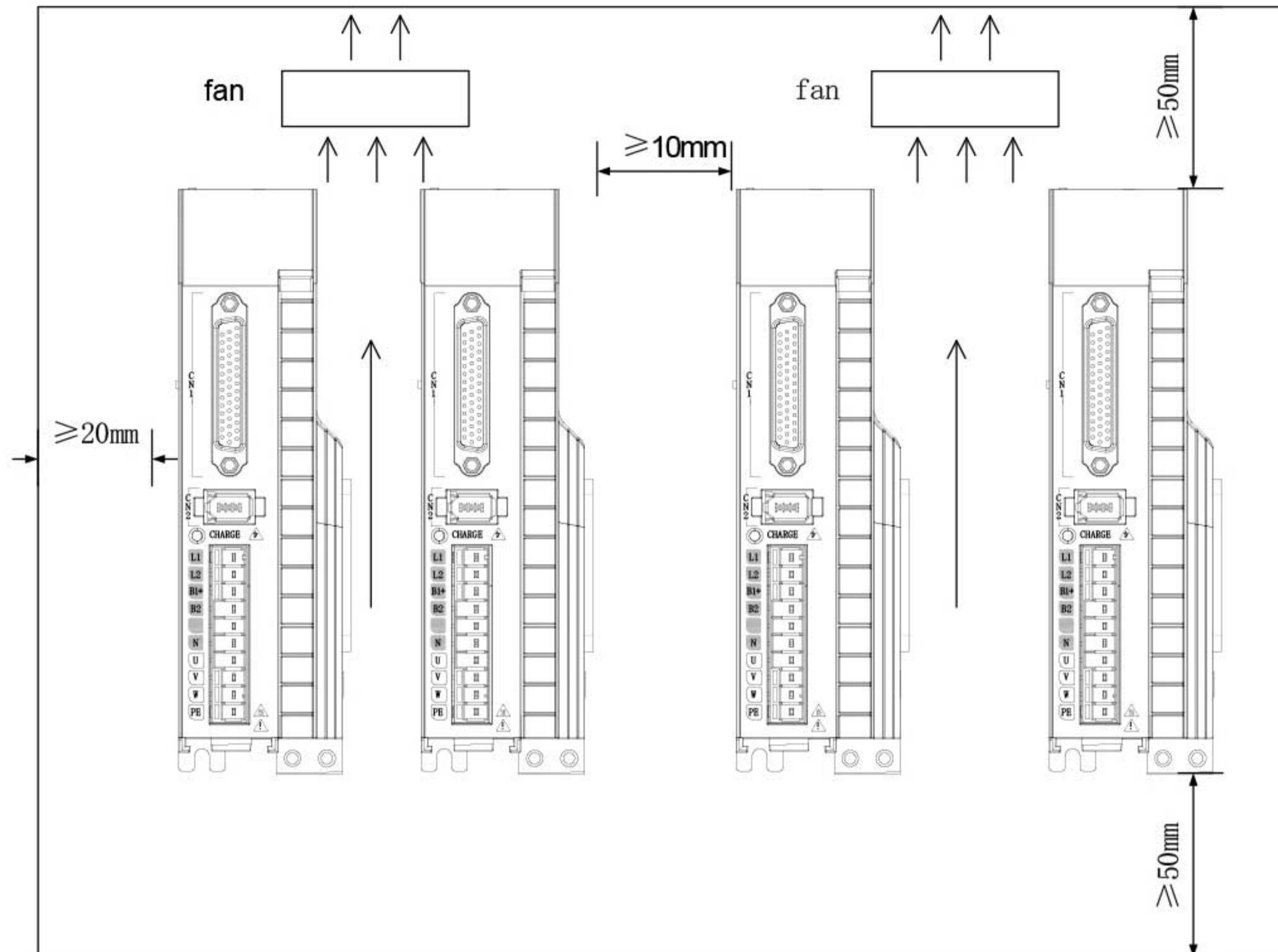

temperature of the internal boards does not exceed 55°C, it is necessary to install a fan or cooler for cooling.

The surface of the heat sink will be 30°C higher than the surrounding temperature.

Use heat-resistant materials for wiring materials, and isolate them from devices and wiring that are easily affected by temperature.

The service life of the servo drive depends on the temperature around the internal electrolytic capacitor. When the electrolytic capacitor reaches the end of its service life, the

electrostatic capacitance decreases and the internal resistance increases. Due to the above reasons, please be aware that it will cause over voltage alarms, malfunctions caused by noise, and damage to various components. The life of an electrolytic capacitor is about 5 to 6 years under the conditions of "an average of 30°C per year, a load rate of 80%, and an average of 20 hours a day."

2.2 Servo Motor Installation

2.2.1 Install site

- Do not use this product near corrosive and flammable gas environments such as hydrogen sulfide, chlorine gas, ammonia, sulfur, chlorinated gas, acid, alkali, salt, etc., and combustible materials;
- Please choose the model with oil seal in the places with grinding fluid, oil mist, iron powder, cutting, etc.;
- Places away from heat sources such as stoves;
- Do not use the motor in a closed environment. A closed environment will cause the motor to heat up and shorten its life.

Environment condition

Figure 2-2 Motor installation environment

Item	Description
Use ambient humidity	0~40°C (non-freezing)
Use ambient humidity	20~80%RH (no condensation)
Storage temp.	-20~60°C
Storage temp.	20~90%RH (no condensation)
Shock	<49m/s ²
Impact	<490m/s ²
protect level	IP67(except for the through-shaft section and motor connectors)
Altitude	<1000m

2.2.3 Notes

Figure 2-2 Install notes

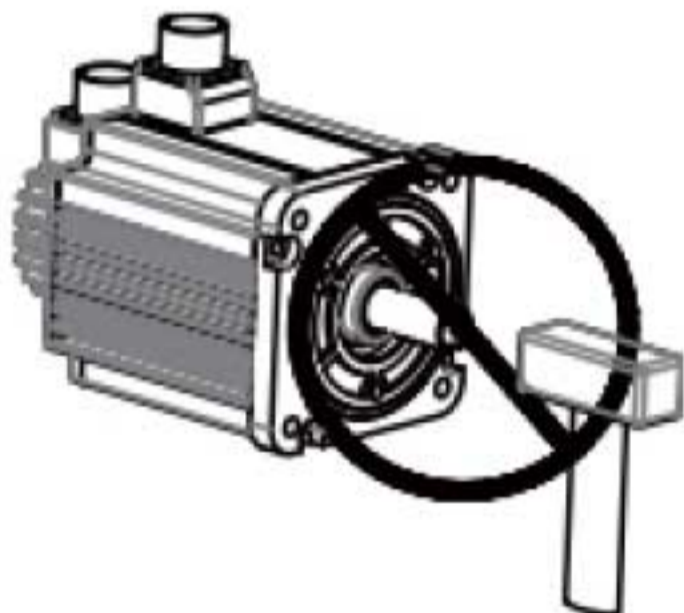
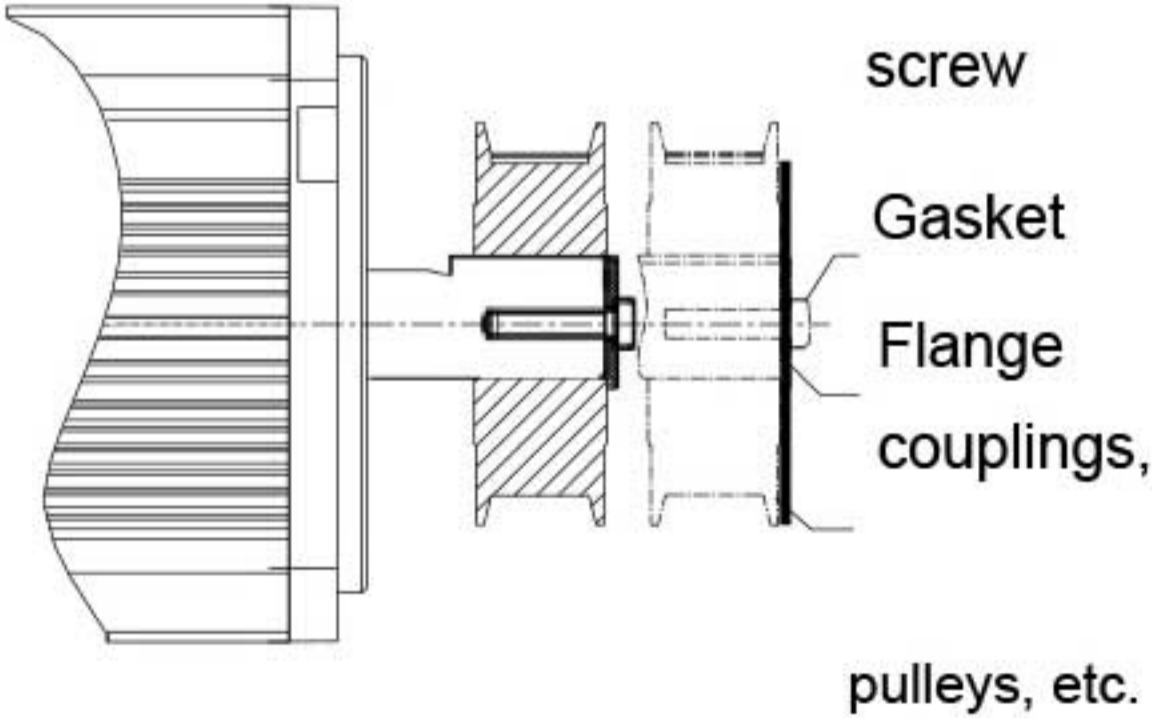
Item	Description
Anti-rust treatment	Before installation, please wipe clean the "anti-rust agent" on the shaft extension end of the servo motor, and then do the relevant anti-rust treatment.
Encoder Note	<p>During the installation process, it is forbidden to hit the shaft extension, otherwise the internal encoder will be broken.</p> 
	 <ul style="list-style-type: none"> ◆ When installing a pulley on a servo motor shaft with a keyway, use a tapped hole on the shaft end. ◆ To install the pulley, first insert the stud into the threaded hole of the shaft. Use a washer on the face of the coupling end and gradually lock it into the pulley with a nut. ◆ For shafts without keyway, use friction coupling or similar. ◆ When removing the pulley, use the pulley remover to prevent the bearing from being strongly

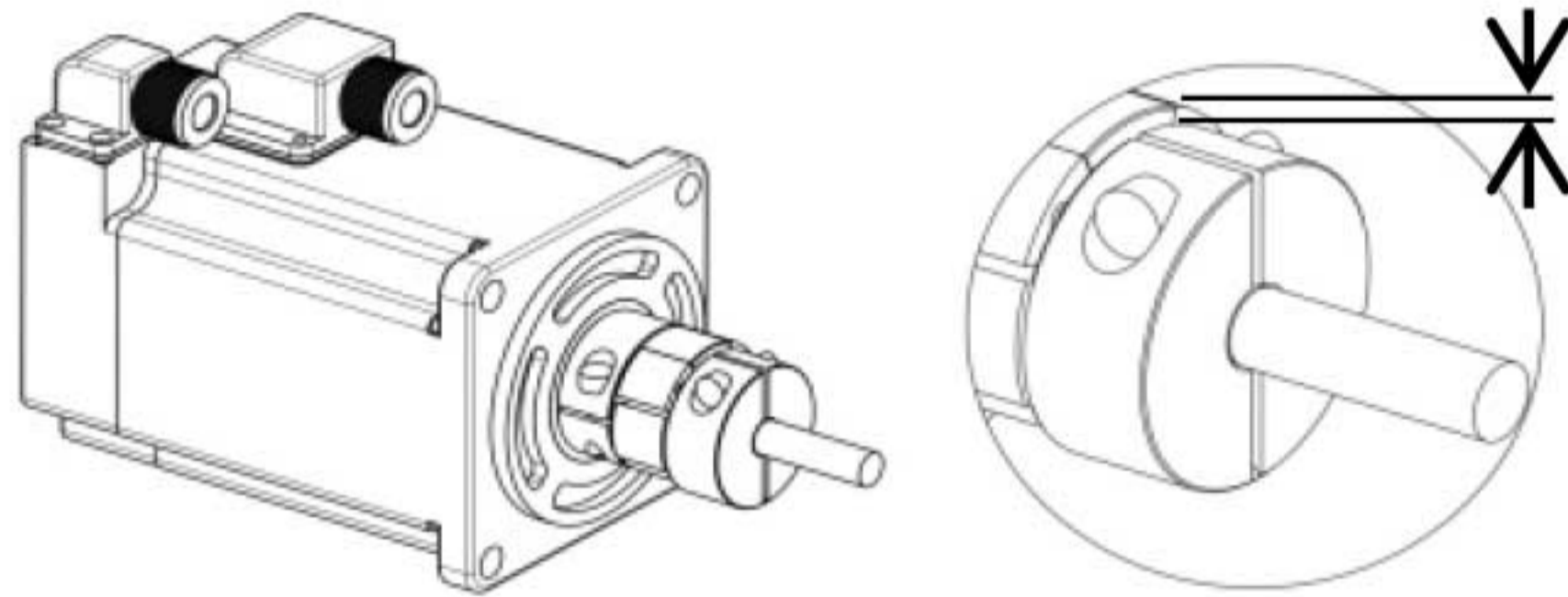
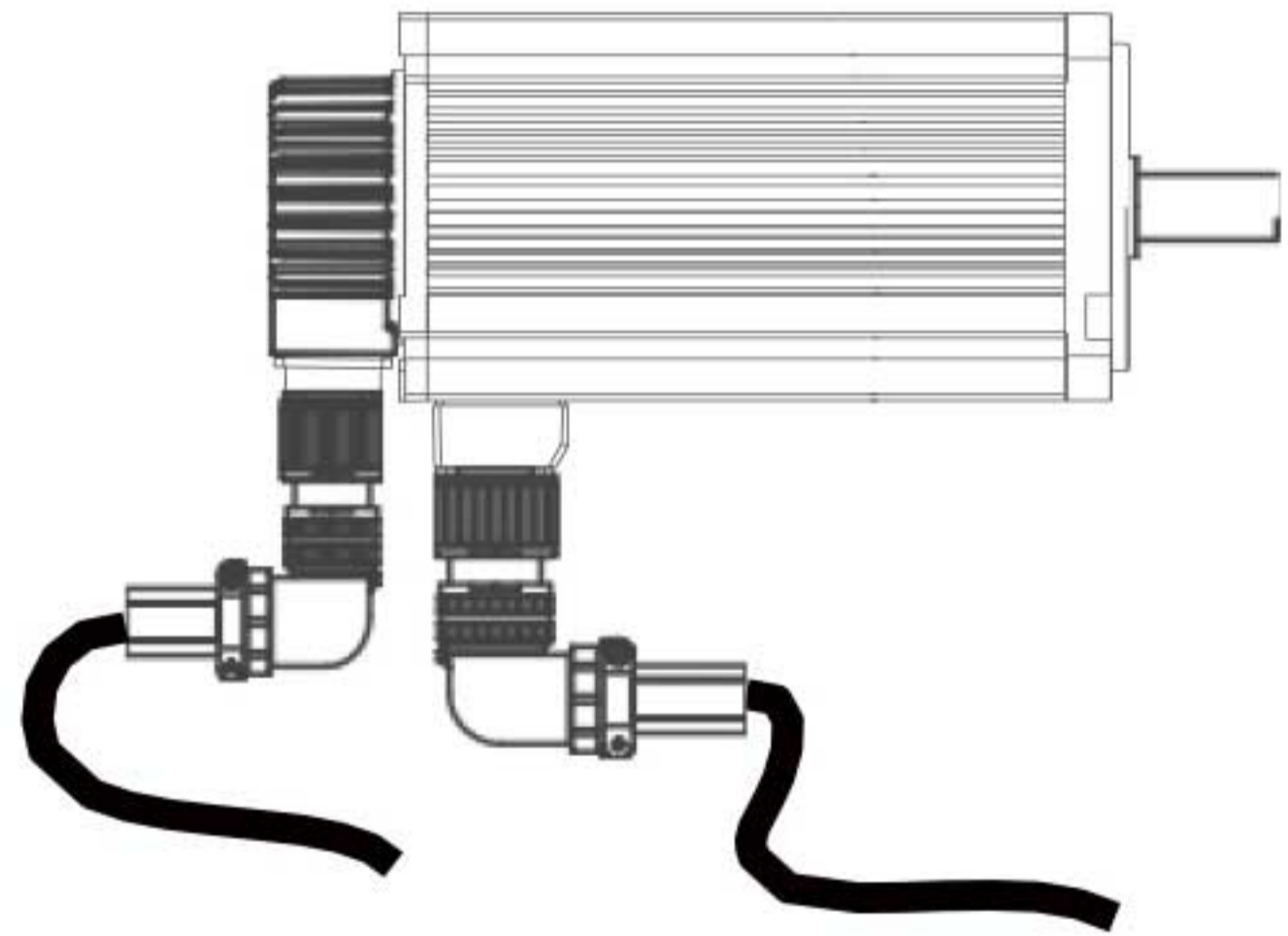
Item	Description
	<p>impacted by the load.</p> <ul style="list-style-type: none"> ◆ For safety, install protective covers or similar devices, such as pulleys mounted on shafts, in the swivel area.
Centering	<p>When connecting with the machine, please use the coupling, and keep the axis of the servo motor and the axis of the machine in a straightline.</p> <p>When installing the servo motor, make it meet the centering accuracy requirements shown in the figure on the left. If the centering is insufficient, vibration will occur, which may damage bearings and encoders.</p> <div data-bbox="463 802 1591 1111">  <p>Measure at four positions on the entire circumference, concentricity deviation $\leq 0.03\text{mm}$</p> </div>
Install direction	<p>Servo motors can be installed in the horizontal or vertical direction.</p>
oil or water use condition	<ul style="list-style-type: none"> ◆ Do not use the motor and cable immersed in oil or water; <p>When using it in a place where there are water droplets, please use it after confirming the protection level of the servo motor. (Except the shaft penetration part)</p> <ul style="list-style-type: none"> ◆ In applications with liquid, please install the motor wiring port downward (as shown in the figure below) to prevent the liquid from flowing along the cable to the motor body; <div data-bbox="612 1693 1240 2149">  </div> <ul style="list-style-type: none"> ◆ Please specify a servo motor with an oil seal when using it in a place where oil droplets may drip onto the shaft penetration. <p>Conditions of use for servo motors with oil seals:</p> <ol style="list-style-type: none"> 1) When using, please make sure that the oil level is lower than the lip of the oil seal; 2) When the servo motor is installed vertically upward, do not allow oil to accumulate on the lip of the oil seal.
The stress condition of	<p>Do not "bend" or apply "tension" to the wire, especially the core wire of the signal wire is 0.2mm or</p>

Item	Description
the cable	0.3mm, which is very thin, so when wiring (use), please do not make it too tight.
Handling of the connector part	<p>Regarding the connector section, please note the following:</p> <ul style="list-style-type: none"> ◆ When connecting the connector, please confirm that there is no foreign matter such as garbage or metal pieces in the connector. ◆ When connecting the connector to the servo motor, be sure to connect it from the main circuit cable side of the servo motor first, and the ground wire of the main cable must be connected reliably. If the encoder cable side is connected first, the encoder may malfunction due to the potential difference between PE. ◆ When wiring, please confirm that the pin arrangement is correct. ◆ The connector is made of resin. Do not apply shock to avoid damaging the connector. ◆ Be sure to hold the main body of the servo motor when carrying out the transportation work with the cables connected. If you handle only by the cable, you may damage the connector or pull the cable. ◆ If a bent cable is used, be careful not to apply stress to the connector part during the wiring work. If stress is applied to the connector portion, it may cause damage to the connector.

2.2.4 Wiring of the motor



1. Power socket:

Flange size 90 Power line sockets for motors up to and including (4-pinAMP socket)

Terminal Pin No.	1	2	3	4
Signal	U	V	W	PE

Power line socket for motors with flange surface 110 and above (4-pin aviation socket)

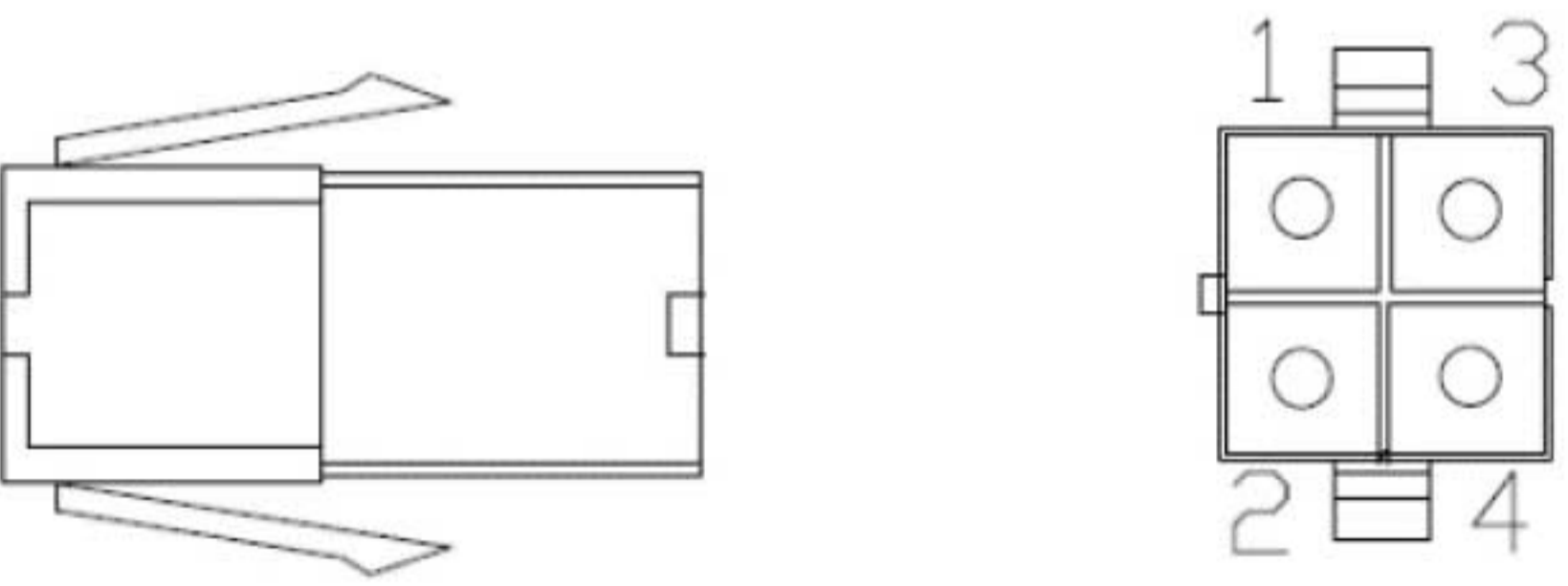
Terminal Pin No.	1	2	3	4
Signal	PE	U	V	W

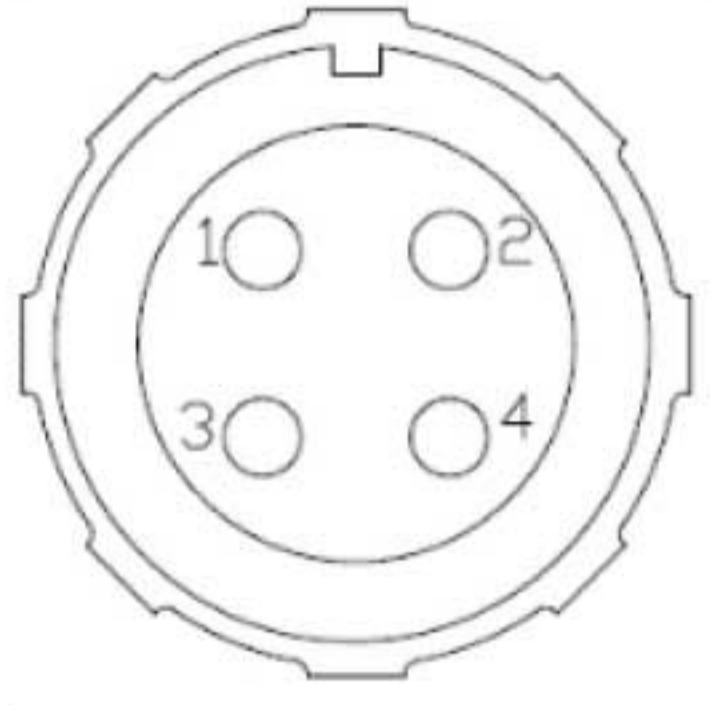
4-pinAMP socket	4-pin angled aviation socket	4-pin straight aviation socket
 <p>1-U、2-V、3-W、4-PE</p>	 <p>1-PE、2-U、3-V、4-W</p>	 <p>1-U、2-V、3-W、4-PE</p>

2. Encoder socket:

110-180 Absolute encoder socket (15 cores)

Terminal	1	2	3	6	9	12	15
Signal	PE	5V	GND	E+	E-	SD+	SD-

60-80 Absolute encoder socket (9 cores)

Terminal	1	2	3	7	9	4	6
Signal	PE	5V	GND	SD+	SD-	E+	E-

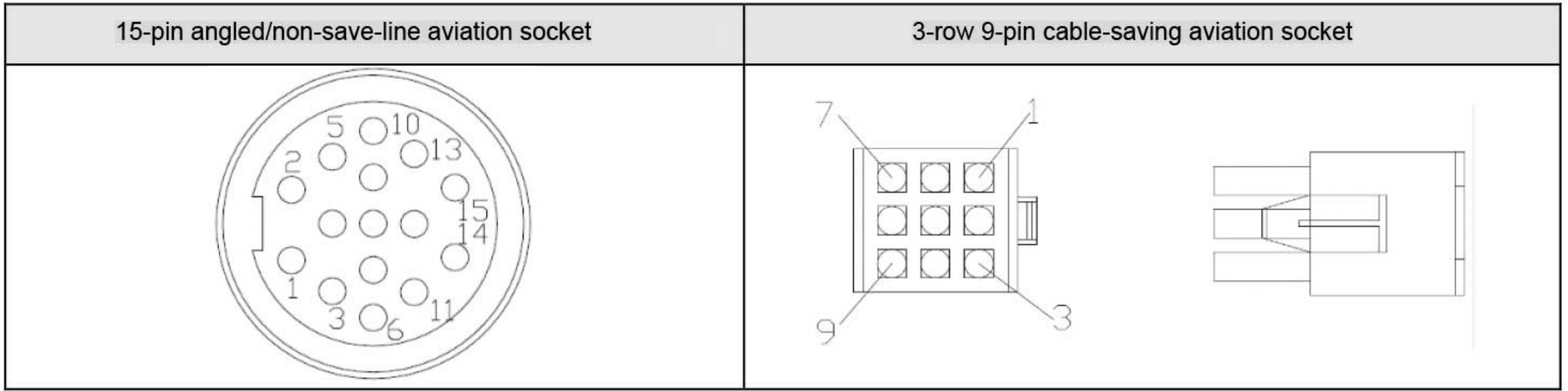

Chapter 3 Instructions of Connection

3.1 The name of each part of the drive

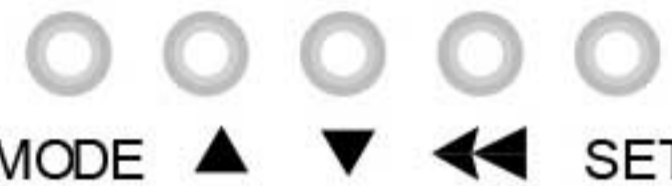
project	Specification
CN3、CN4 Comm.terminal	Internal parallel, with RS-232、RS-485、Canopen Comm. command device connection.
digital tube display	5-digit 7-segment LED digital tube is used to display the running status and data setting.
key operator	 <p> Press the key to display the setting value of each parameter, enter the data setting state (long press the parameter to confirm) Shift the current blinking bit to the left The set value can be reduced to act as a reverse ed. start key during JOG operation in auxiliary function mode. The set value can be increased it acts as a forward rotation start key when the auxiliary function mode JOG is running. Switch basic mode: status display, auxiliary function, parameter setting, monitoring </p>
CN1 I/O terminal	Ports for command input signals and other input signals.
CN2 Motor encoder terminal	Connect to the motor encoder terminals.
CHARGE Bus voltage indicator	Used to indicate bus capacitor is in a charged state. when light on, even if the main circuit power is turned off, the capacitors in unit may still have electric charges. so, do not touch the power terminals when the light is on to avoid electric shock.
L1、L2 Main power terminal	Simplex AC200V-240V, -15%~10%, 50/60Hz.
B1+、B2、B3 Braking resistor terminal	if using an external braking resistor, connect a resistor between B1+ and B2; when using an internal resistor, short-circuit B2 and B3 (B2 and B3 are short-circuited at factory).
U、V、W、PE Motor power terminal and ground terminal	It must be in one-to-one correspondence with the UVW terminals of the motor.

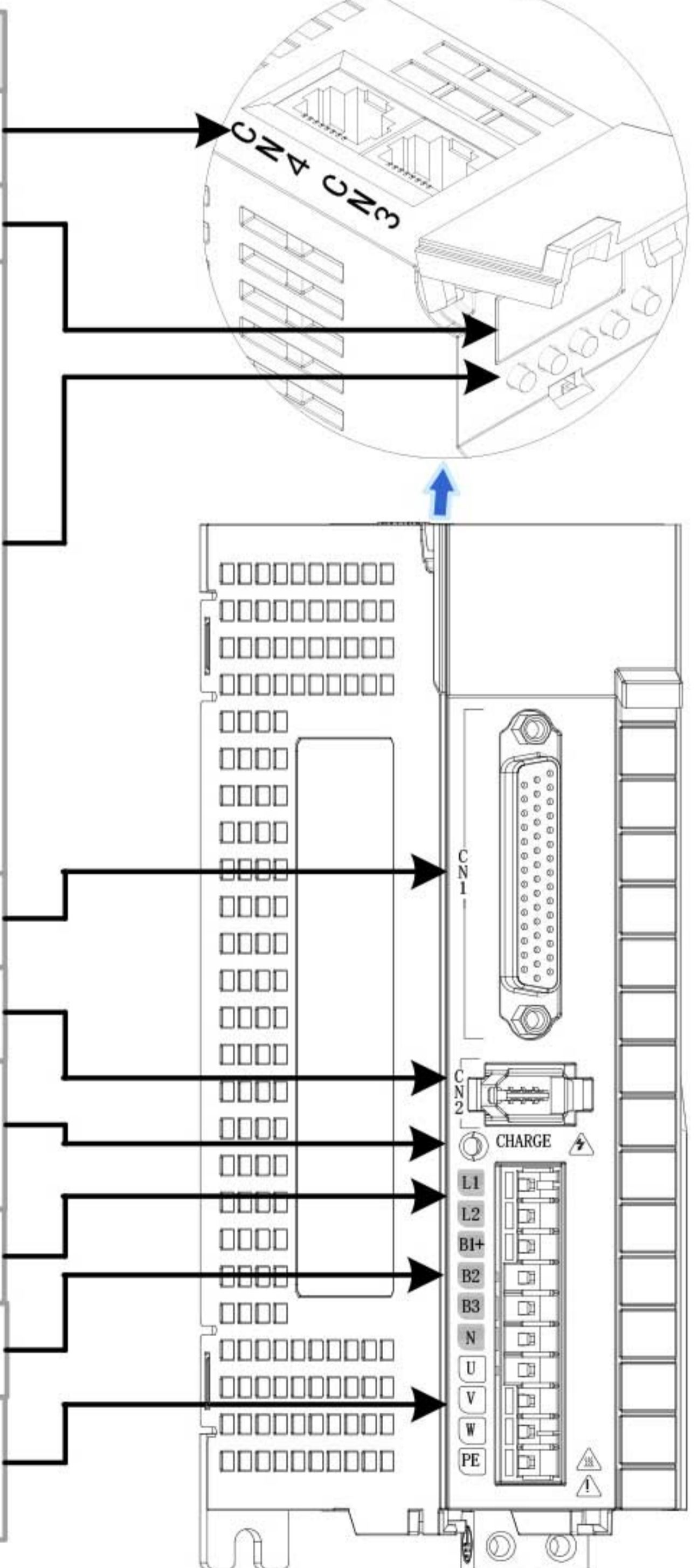

3.2 I/O Terminal arrangement

3.2.1 CN1 Terminal arrangement description

15 +5V	14 COM	13 PZO+	12 DI9	11 COM+	10 DI2	9 DI1	8 DI4	7 DO1+	6 DO1-	5 DO2+	4 DO2-	3 DO3+	2 DO3-	1 DO4+
30 DI8	29 GND	28 DO5+	27 DO5-	26 DO4-	25 PBO+	24 PZO-	23 PBO-	22 PAO-	21 PAO+	20 AI1	19 GND	18 AI2	17 +24V	16 GND
44 PZ-OUT	43 PULSE-	-	41 PULSE+	-	39 SIGN-	-	37 SIGN+	-	35 PULLHI	34 DI3	33 DI5	32 DI6	31 DI7	

Model type show

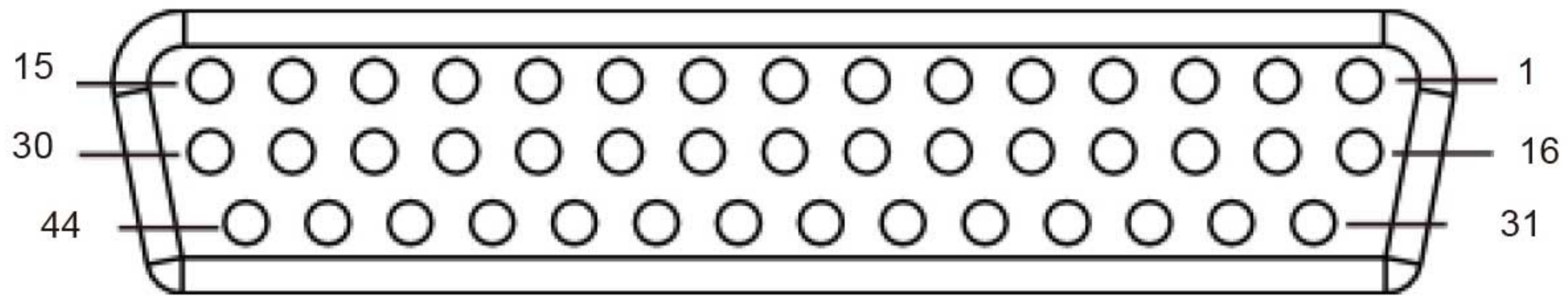

3.2.2 CN2 Illustration of the terminal arrangement of the absolute encoder

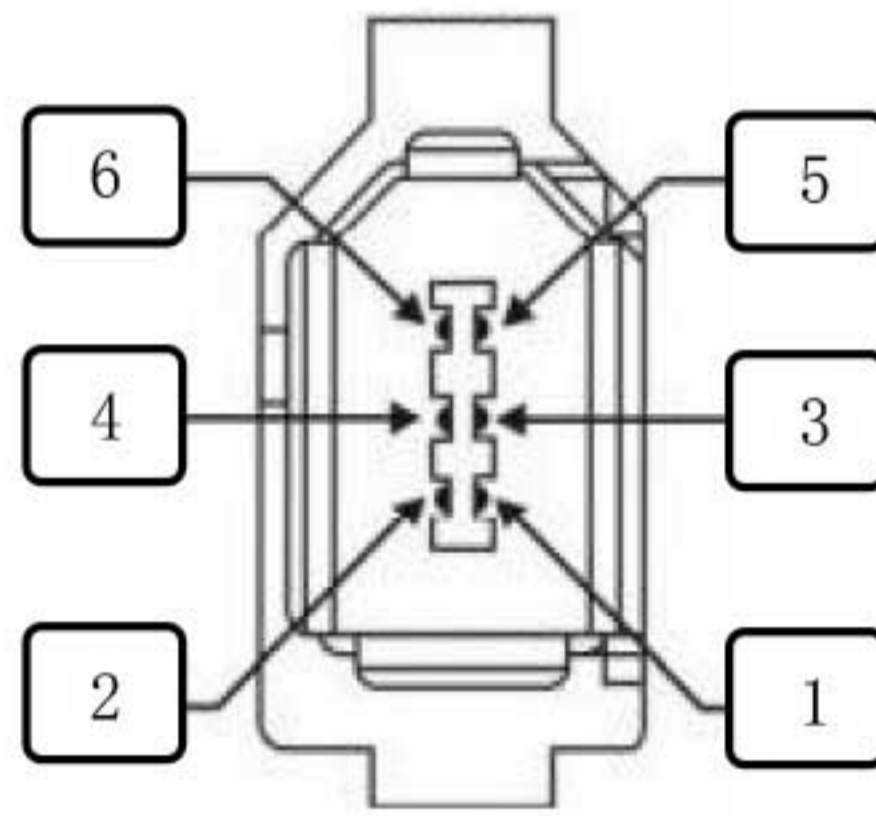

Terminal	Name	Function
1	+5V	PG power+5V
3	-	-
5	PS+	S+ phase

Terminal	Name	Function
2	0V	Signal
4	-	-
6	PS-	S-phase

3.2.3 CN3、CN4 Illustration of terminal arrangement

Pin	Definition	Description	Terminal Pinout
1	CANH	CAN comm. port	
2	CANL		
3	CGND	CAN comm. port	
4	RS485+	RS485 comm. port	
5	RS485-		
6	RS232-TXD	RS232 Sending end, connected with the receiving end of the host computer	
7	RS232-RXD	RS232 The receiver is connected to the transmitter of the host computer	
8	GND	Ground	
Shell	PE	shield	

3.3 Models and specifications of main circuit connecting cables 3.3.1

Servo Drive Specification

Model E6 Series	Rated input current(A)	Rated output current (A)	Max output current(A)
One phase 220V	200	2.3	5.8
	400	4.0	10.1
	750	7.9	16.9
	1000	11	16.9

3.3.2 Example of power supply wiring

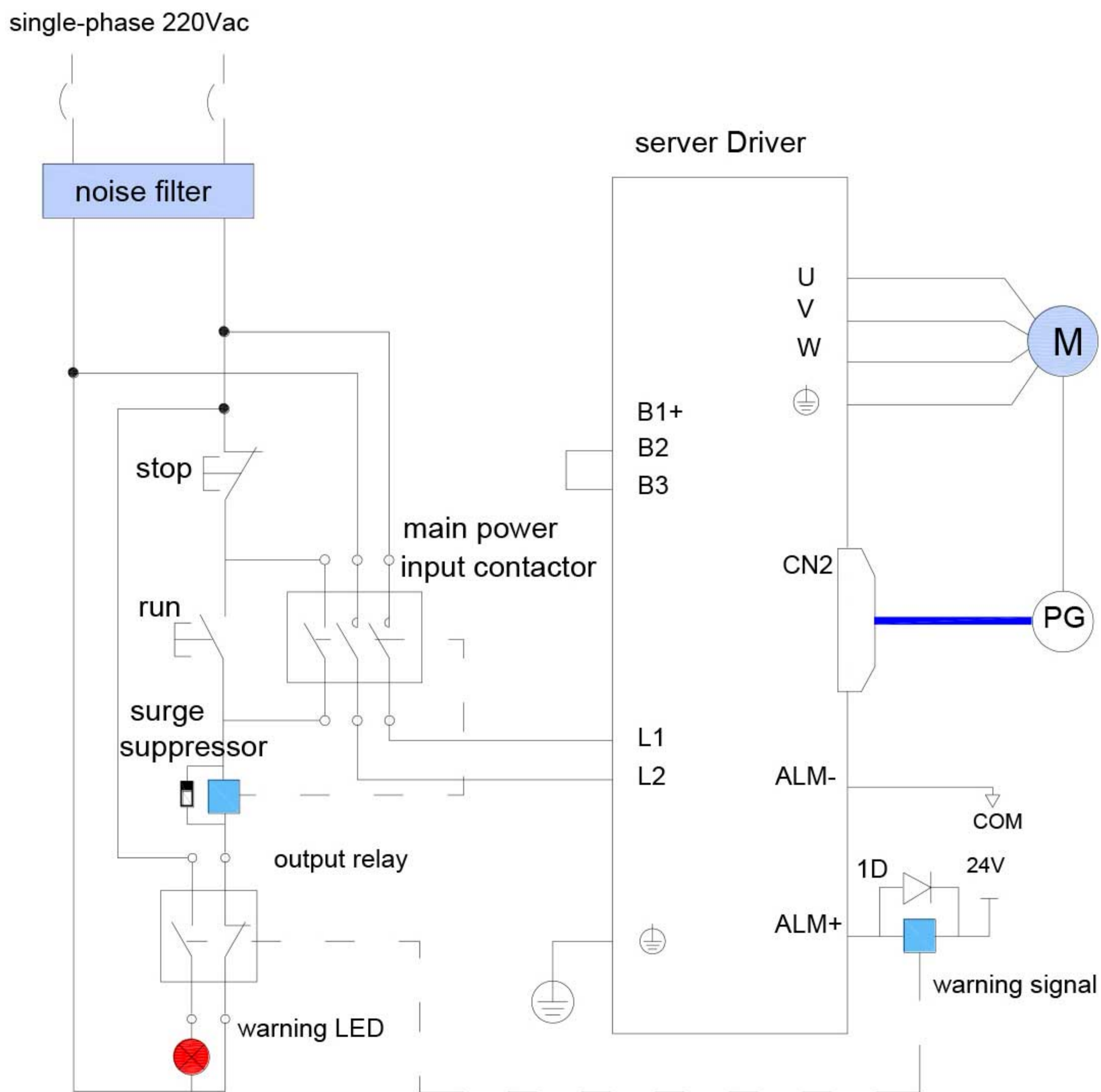

Figure 3-1 single phase 220V Main circuit wiring

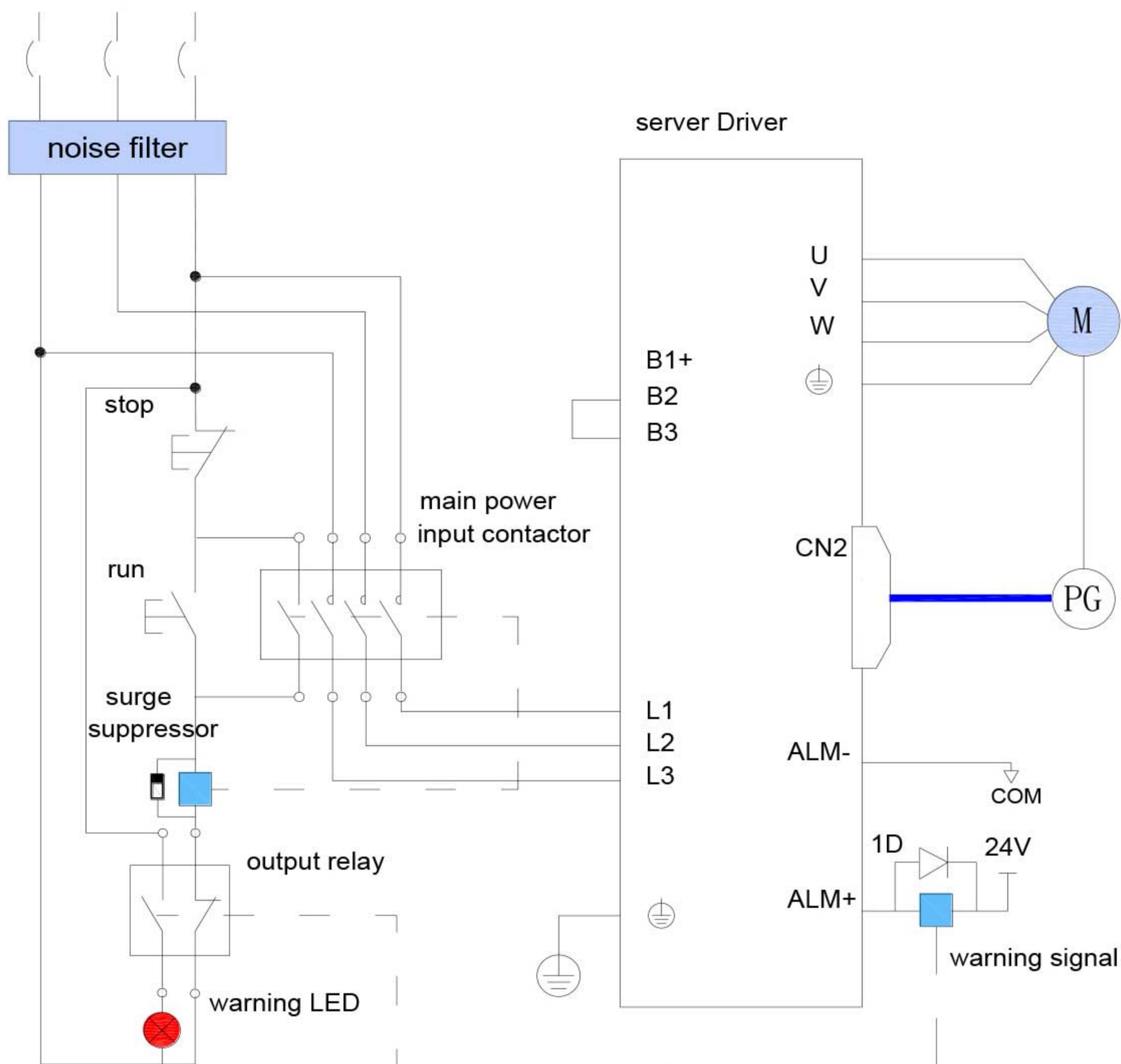
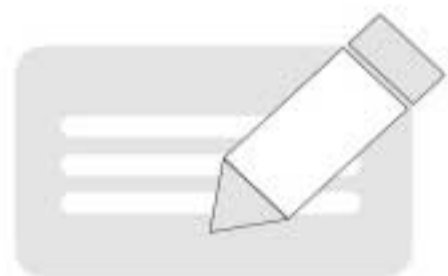

Figure 3-2 single phase 220V, three phase 380V Main circuit wiring

**NOTE**

- ◆ 1KM: Electromagnetic contactor; 1Ry: relay; 1D: Freewheeling diode
- ◆ DO Set as alarm output function(ALM+/-), when the servo drive alarms, the power supply can be automatically cut off, and the alarm light will be on at the same time.

3.3.3 Main circuit wiring precaution

1. Do not connect the input power cable to the output terminals U, V, W, otherwise the servo drive will be damaged;
2. When the cables are bundled and used in pipes, etc., due to poor heat dissipation conditions, please consider the allowable current reduction rate;
3. Please use high-temperature cables in the surrounding high-temperature environment. Generally, the thermal aging of cables will be very fast and cannot be used in a short time; please pay attention to the insulation measures of the cables in the surrounding low-temperature environment. Generally, the surface of cables is easy to harden and rupture in low-temperature environments. ;
4. Please ensure that the bending radius of the cable is more than 10 times the outer diameter of the cable itself to prevent the inner core of the cable from breaking due to long-term bending;
5. Please use a cable with a withstand voltage of AC600V or more and a temperature rating of more than 75°C. The allowable current density of the wire of the cable is around 30°C and under normal heat dissipation conditions. Generally, the total current should not exceed 8A/mm² below 50A, and should not exceed 50A. Should not exceed 5A/mm². For high ambient temperature and bundled cables, the current allowable value needs to be adjusted appropriately. The applicable allowable current density (A/mm²) can be calculated with the following formula: Applicable allowable current density = 8 × Conductor current-carrying density reduction factor × Current correction factor

$$\text{Current correction factor} = \sqrt{(\text{Max. allowable temperature of cable} - \text{ambient temperature}) \div 3}$$

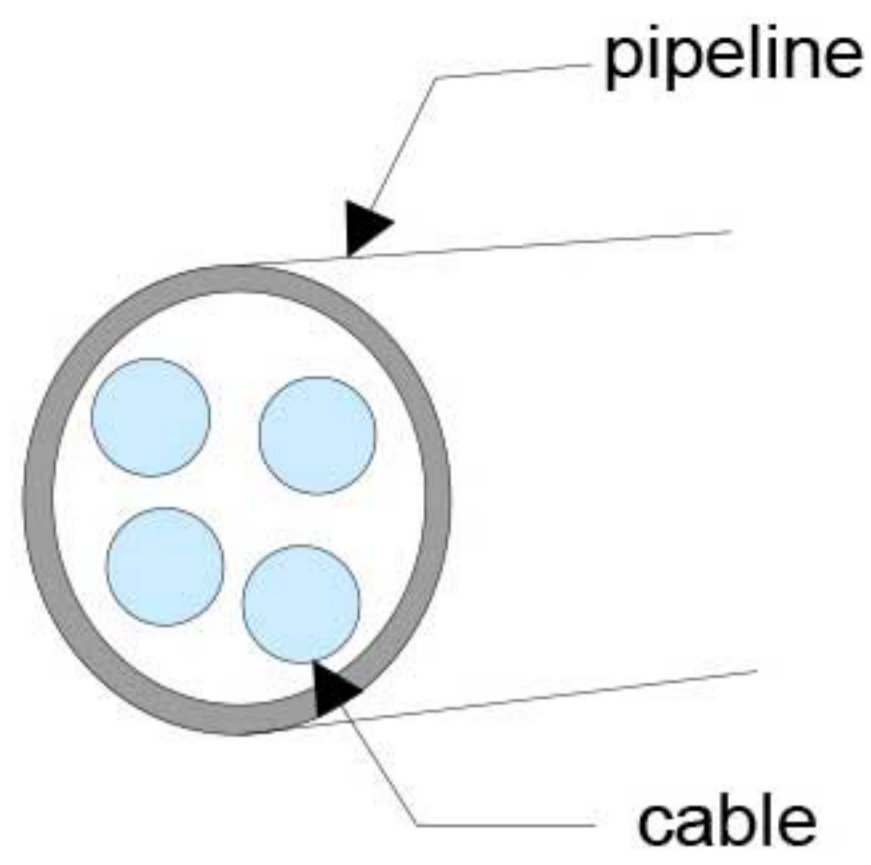

Number of cables in the same pipe	Current reduction factor
Below 3 cable	0.7
4 cables	0.63
5~6 cables	0.56
7~15 cables	0.49

- Do not pass the power cable and the signal cable through the same pipe or bundle them together. To avoid interference, the distance between the two should be more than 30cm.
- Even if the power is turned off, high voltage may remain in the servo driver. Do not touch the power terminals in 5 minutes.
- Do not turn on/off the power frequently. When repeated continuous on/off of the power is required, please control it not less than once a minute. Since there is a capacitor in the power supply part of the servo driver, when the power is turned on, a large charging current will flow (charging time 0.2 seconds). Frequent operation will cause the performance of the main circuit components inside the servo drive to degrade.
- Please use a ground wire with the same cross-sectional area as the main circuit wire. If the cross-sectional area of the main circuit wire is less than 1.6mm², please use a 2.0 mm²ground wire.
- Please connect the servo drive to the ground reliably.
- Do not power on when the terminal block screw is loose or the cable is loose, which may cause a fire.

3.3.4 Power line connection of servo drive and servo motor

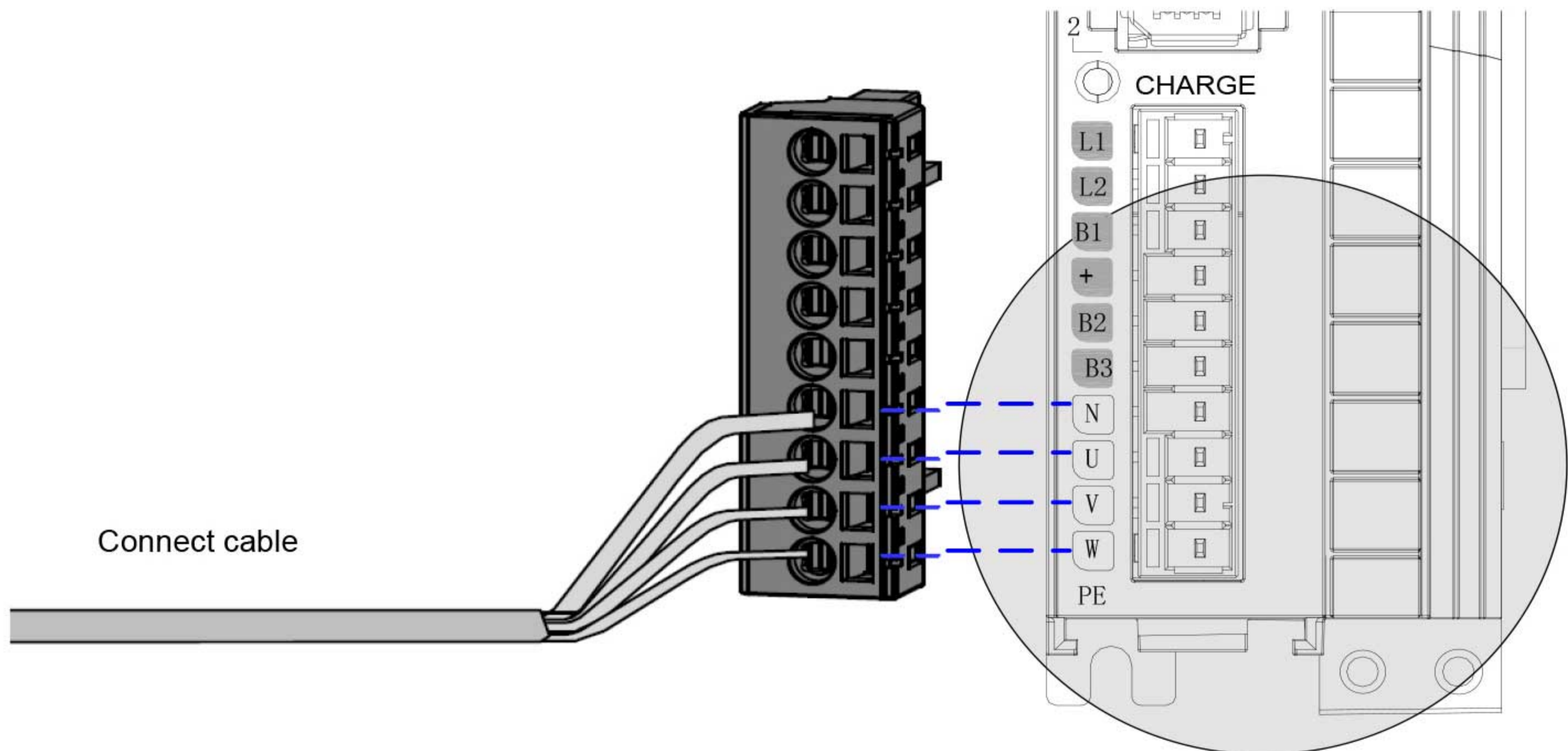

Figure 3-3 Example of connection between servo drive output and servo motor

3.4 Control signal terminal connection method 3.4.1

Position command input signal

The following describes the common command pulse input, command symbol input signal and high-speed reference pulse input and command symbol input signal terminals of the user interface connector.

Sheet 3-2 Position command input signal description

Signal name	Pin No.	Function
PULSE+ PULSE- SIGN+ SIGN-	41 43 37 39	Low-speed pulse input mode Differential drive mode OC mode
HPULSE+ HPULSE-	41 43	High-speed reference pulse input
HSIGN+ HSIGN+	37 39	High-speed position reference symbols
PULLHI	35	External power input terminal of reference pulse
GND	29	Signal ground

The command pulse and symbol output circuit on the host side can be selected from differential driver output or open collector output. The maximum input frequency and minimum pulse width are shown in the table below:

Sheet 3-3 Corresponding relationship between pulse input frequency and pulse width

Pulse mode	Max frequency (pps)	Minimum pulse width (us)
General	Difference	500k
	open collector	200k
High-speed differential	2M	0.25

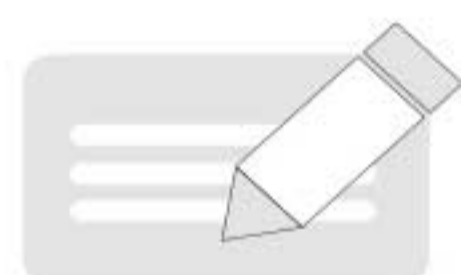

NOTE

- ◆ High-speed pulse and low-speed pulse cannot be used at the same time, only one of them can be used.
- ◆ If the output pulse width of the host device is smaller than the minimum pulse width value, it will cause the driver to receive the pulse error.

1) Low-speed pulse command input

When in differential mode

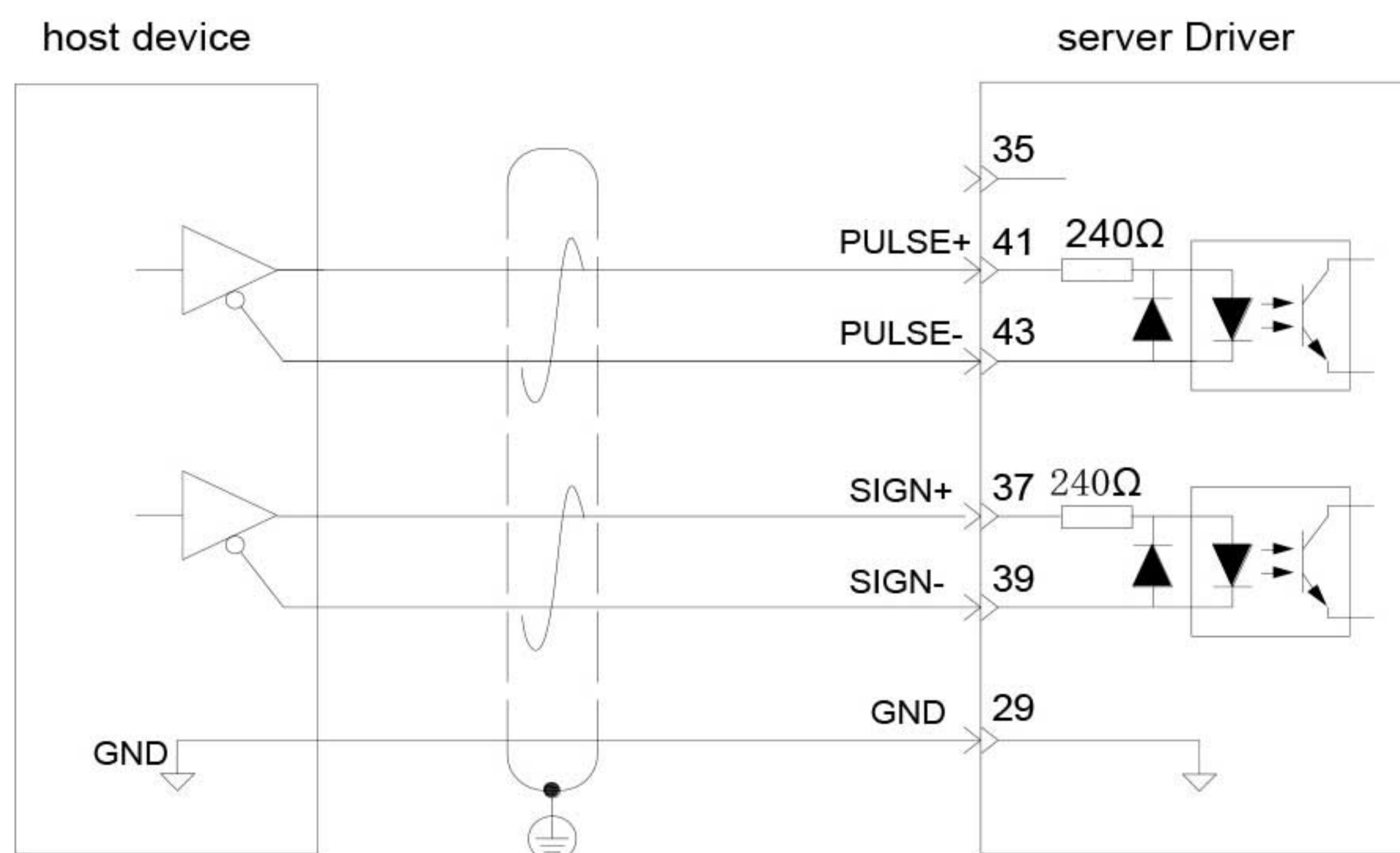

2)When in open collector mode

a)When using the internal 24V power supply of the servo drive

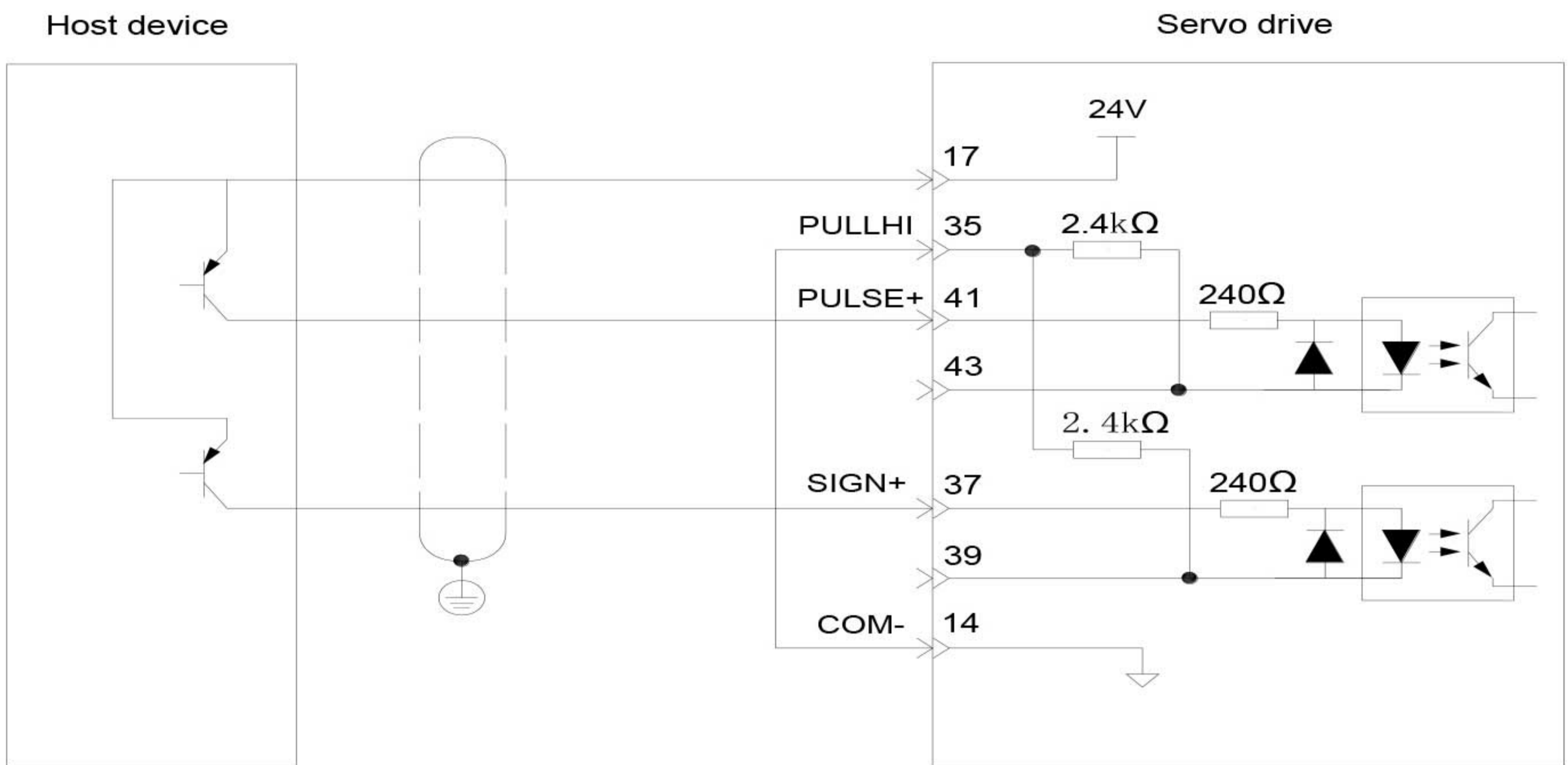
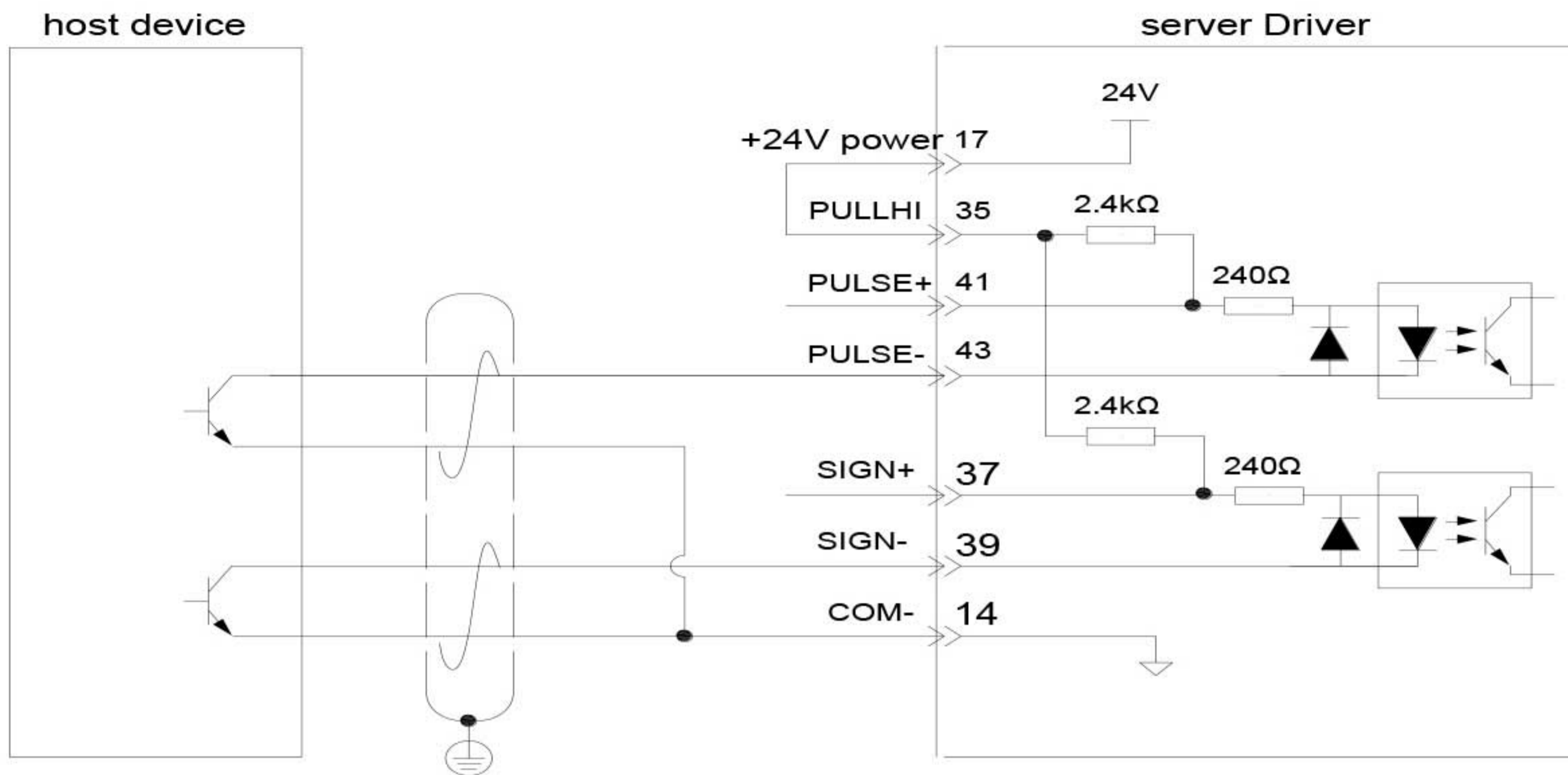

■ Error: 14-pin COM-is not connected, cannot form a closed loop

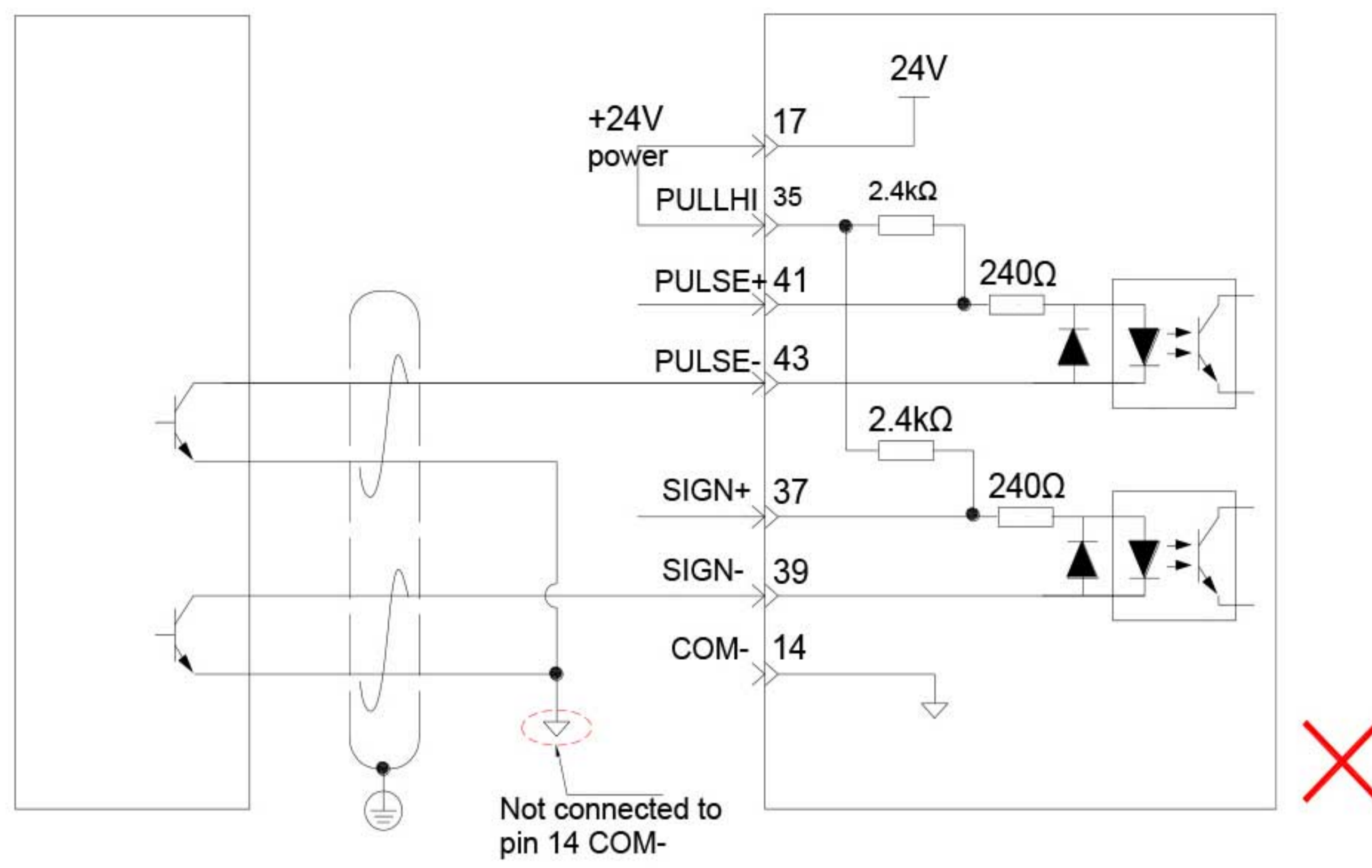

b)When using an external power supply:

Option 1: Use the internal resistance of the driver (recommended solution)

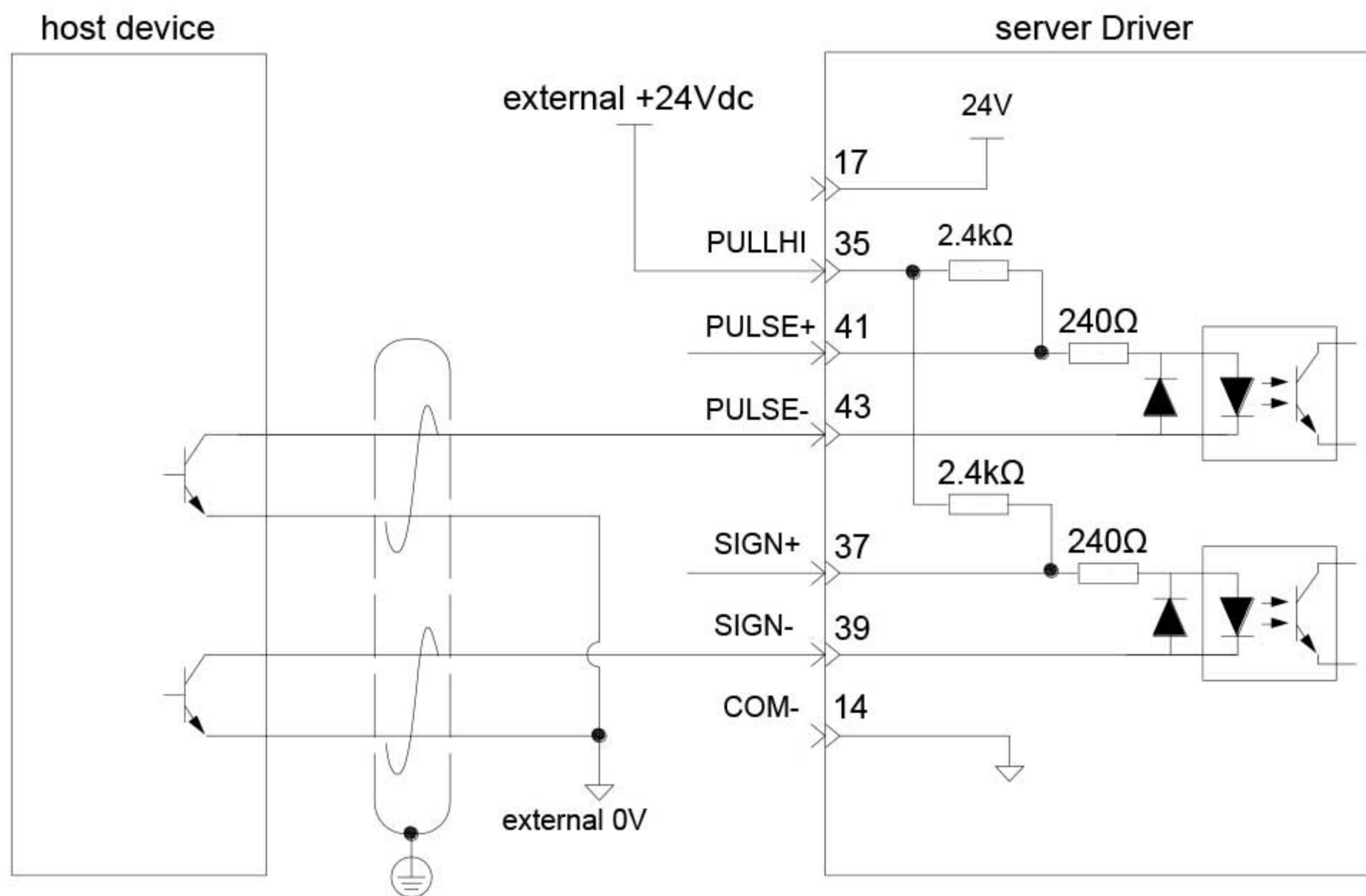

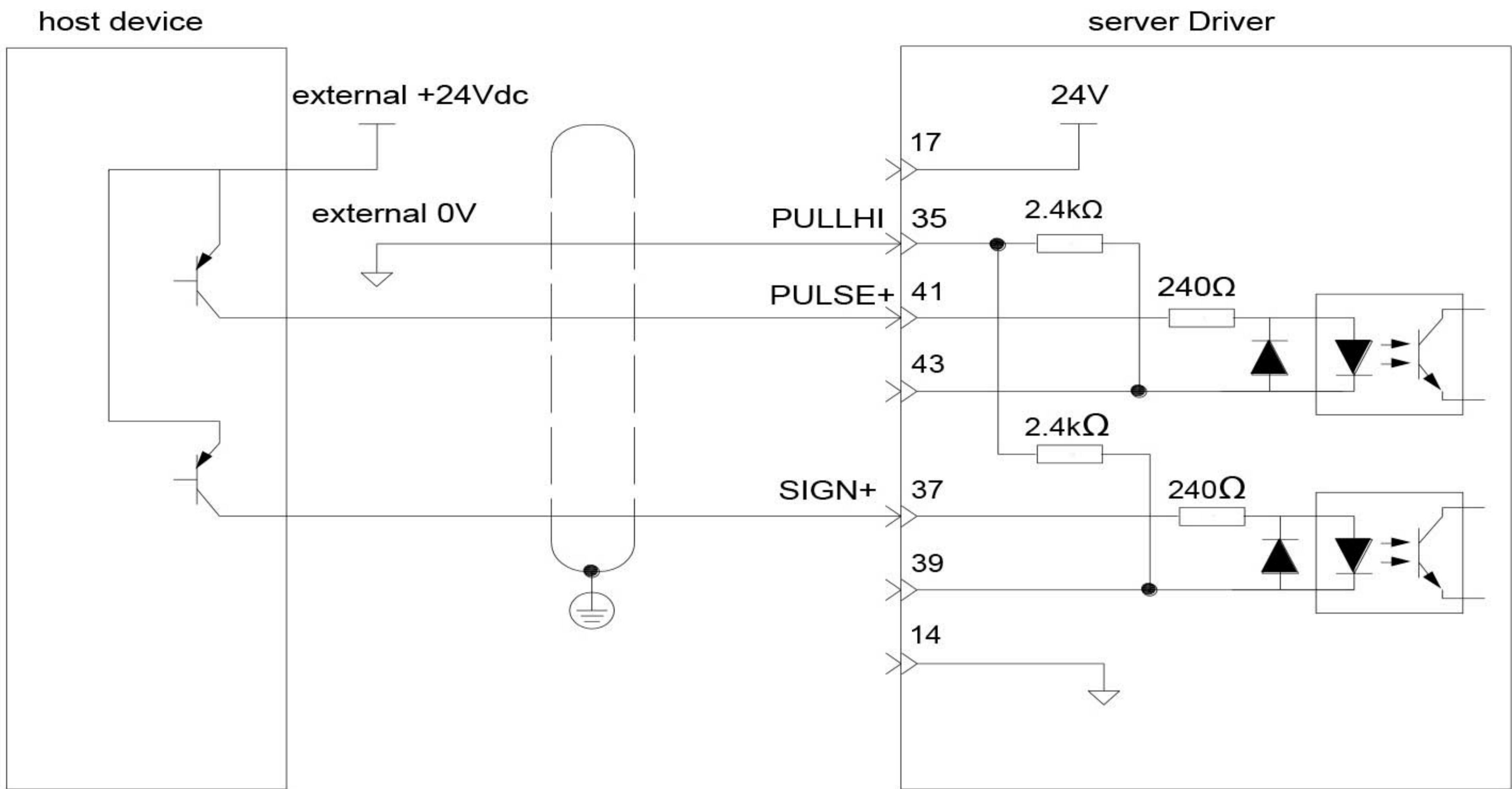

■ Option 2: Use an external resistor

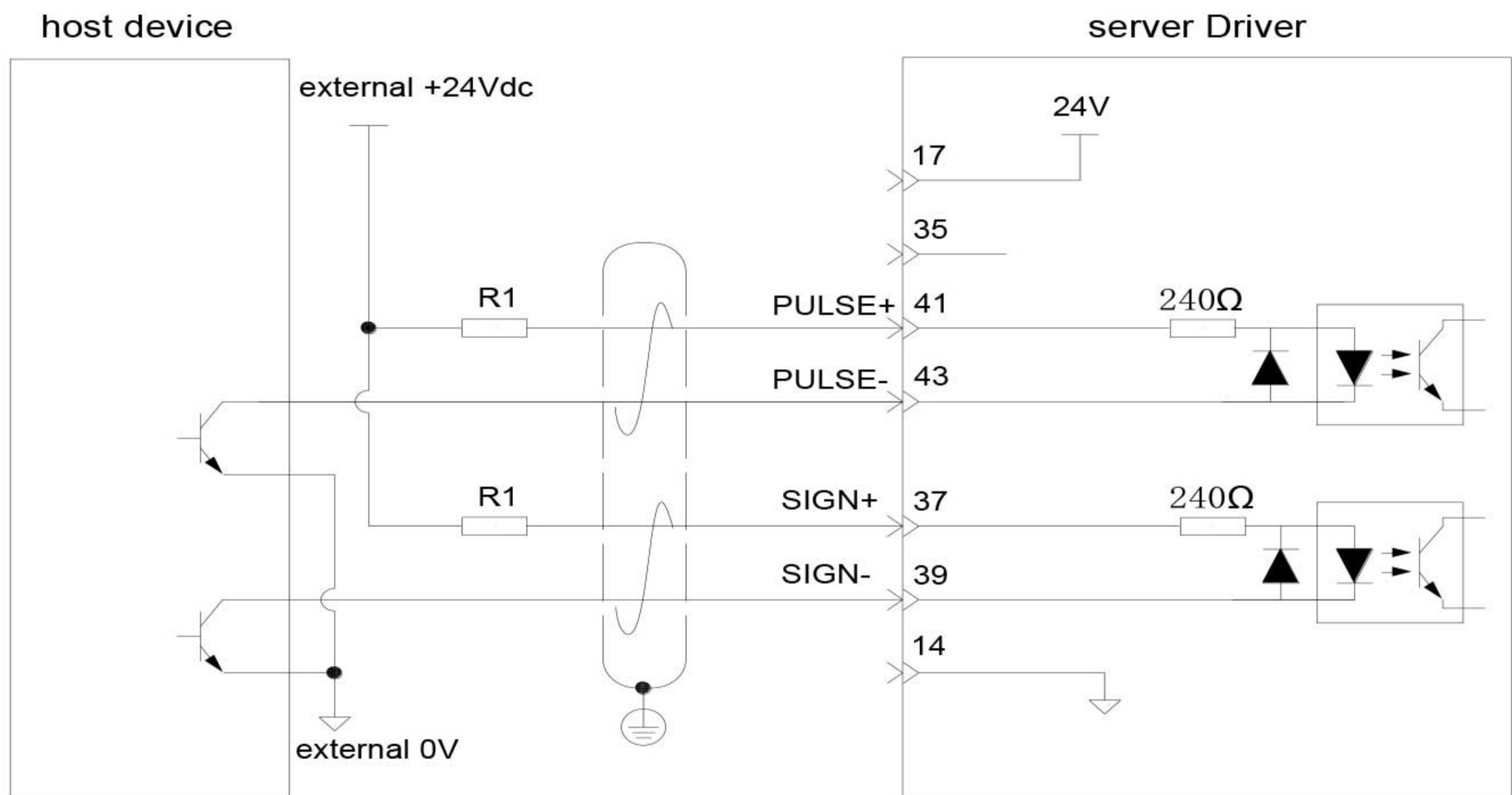

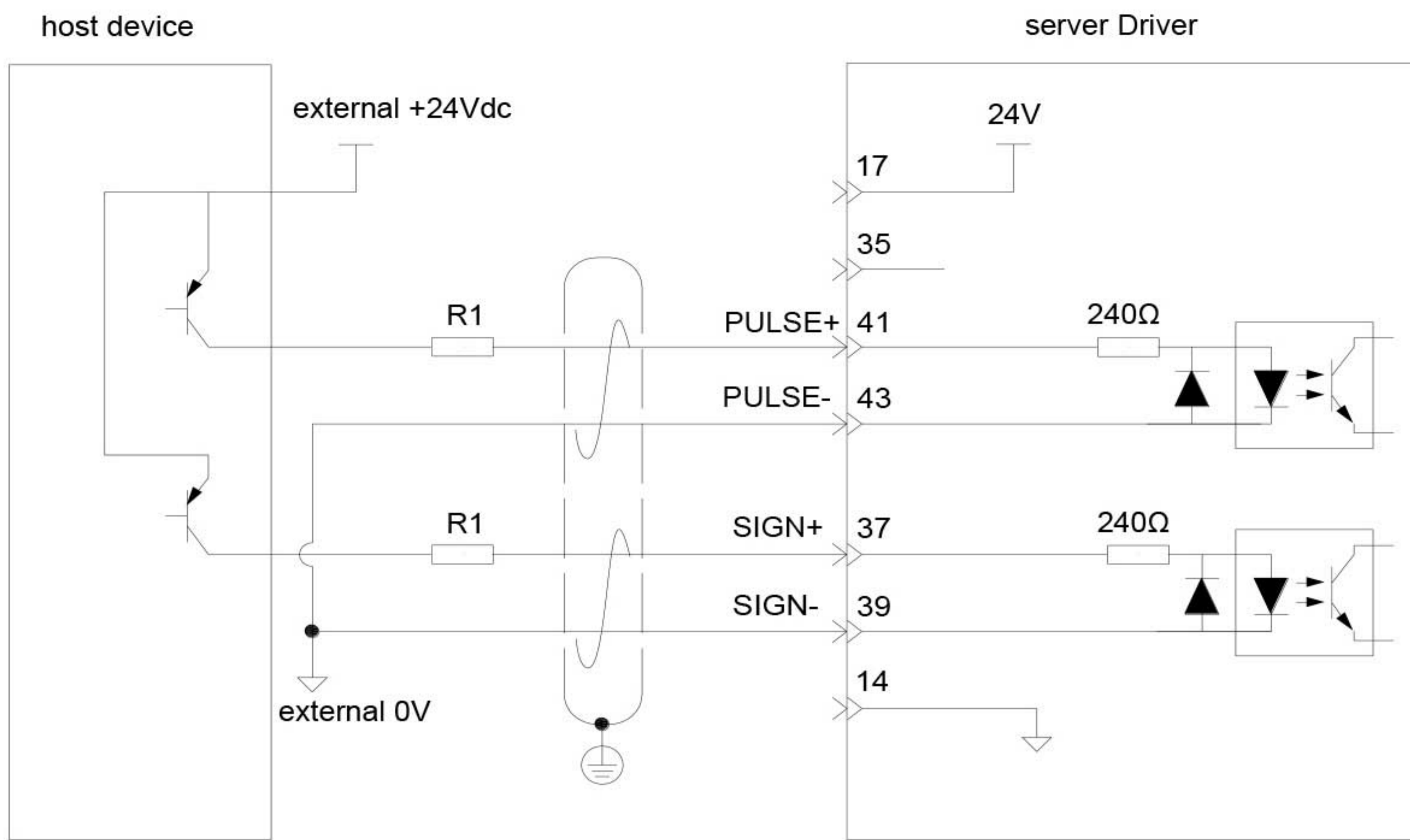

■ The selection of resistor R1 should satisfy the formula: $\frac{V_{cc}-1.5}{R1+240} = 10mA$

Sheet 3-4 recommended R1 brake resistance

VCC voltage	R1 brake resistance	R1 power
24V	2.4kΩ	0.5W
12V	1.5kΩ	0.5W

Wiring error example:

■ Error 1: The current limiting resistor is not connected, resulting in port burnout

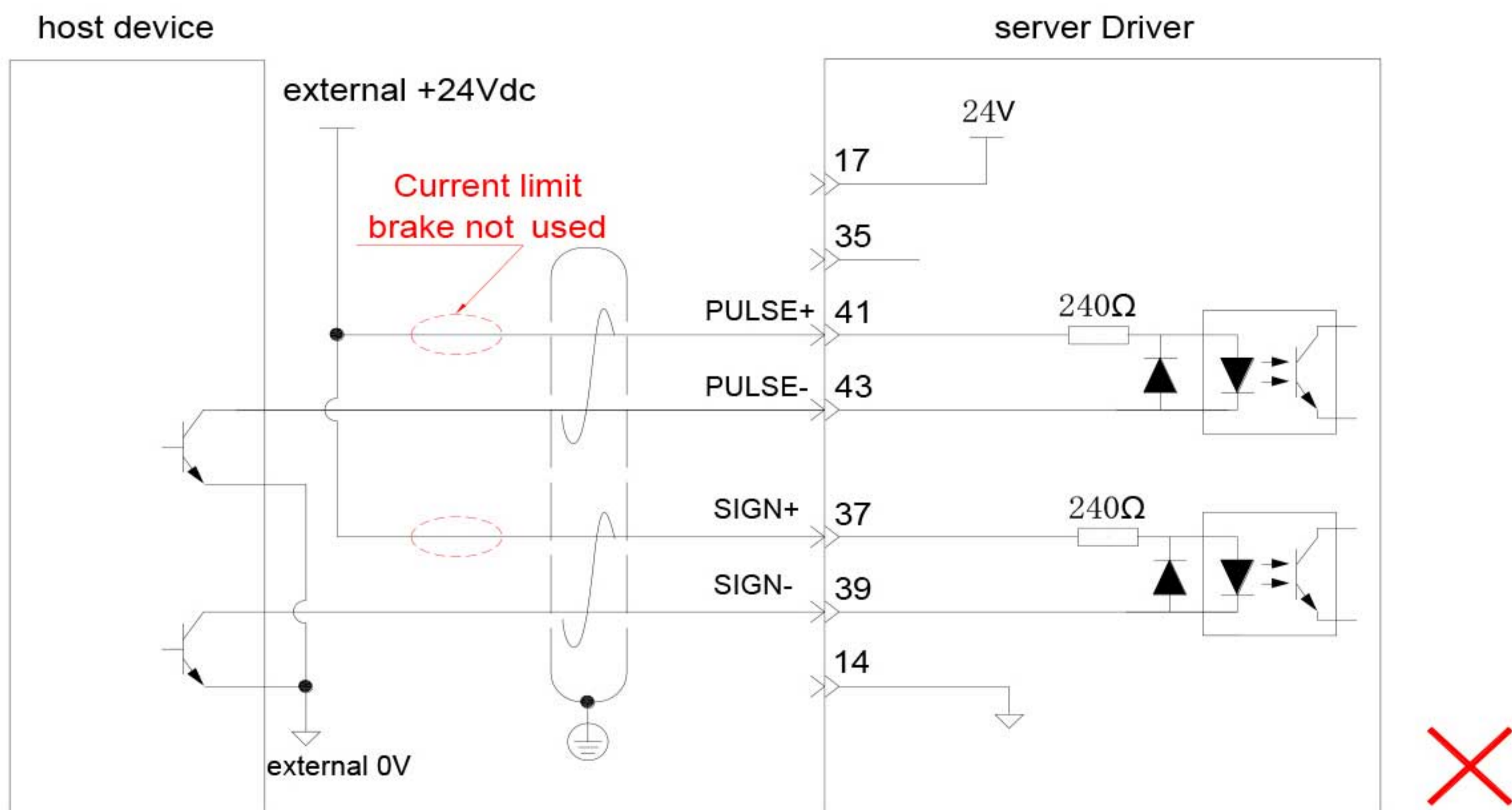

■ Error 2: Multiple ports share current-limiting resistors, resulting in incorrect pulse reception

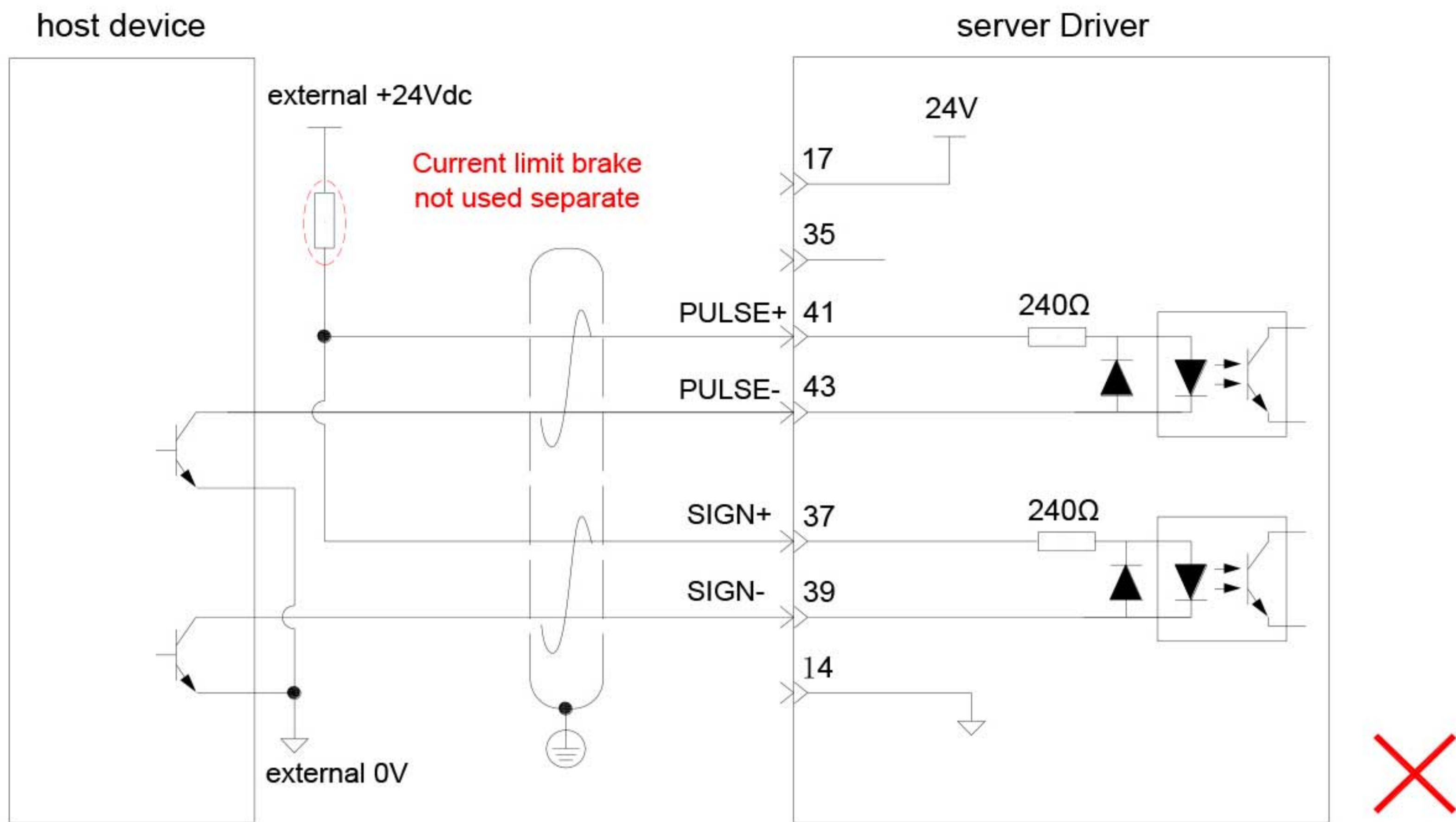

■ Error 3: The SIGN port is not connected, resulting in the two ports not receiving pulses

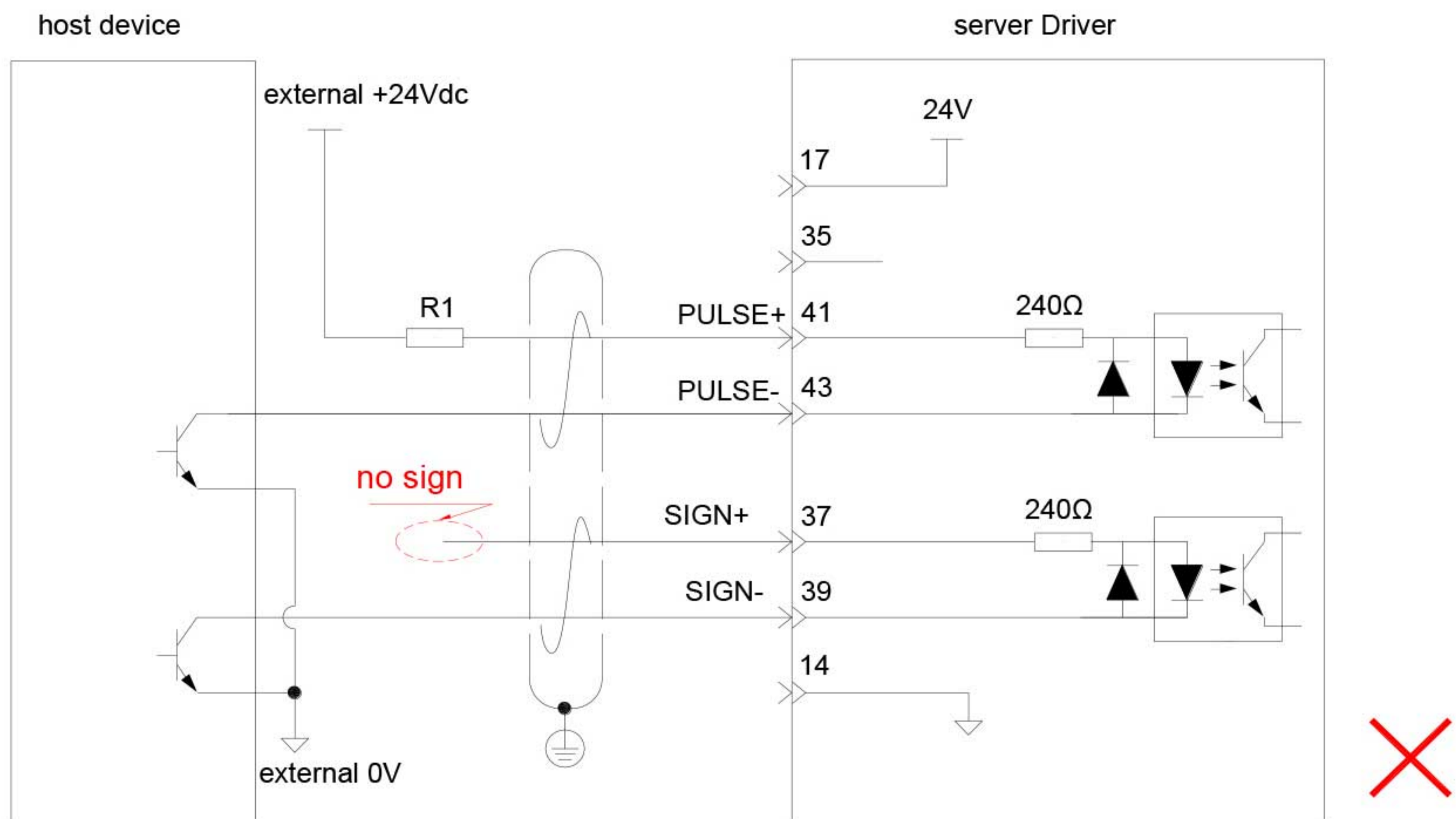

■ Error 4: The port is connected incorrectly, causing the port to burn out

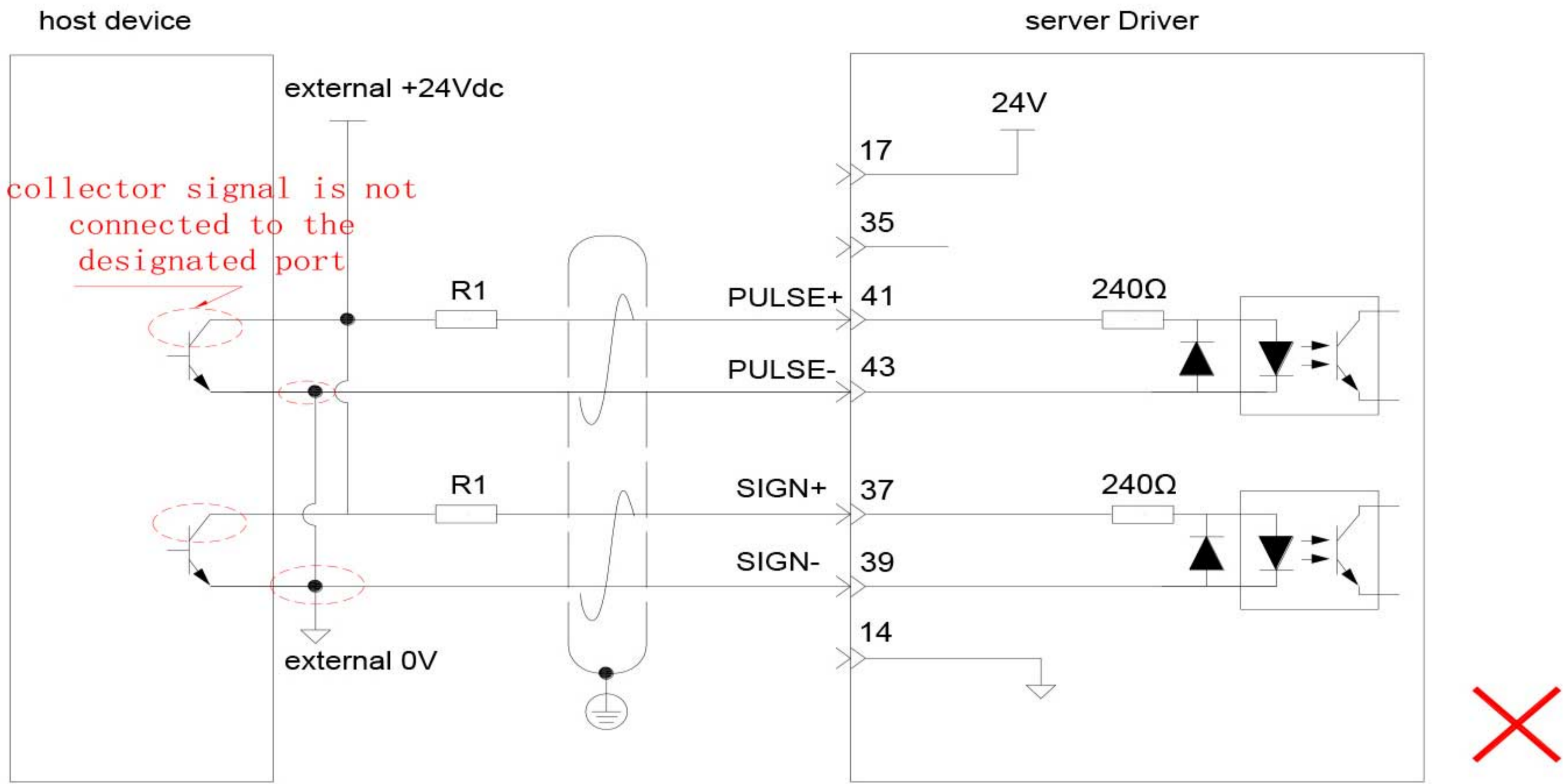

Error 5: Multiple ports share current-limiting resistors, resulting in incorrect pulse reception

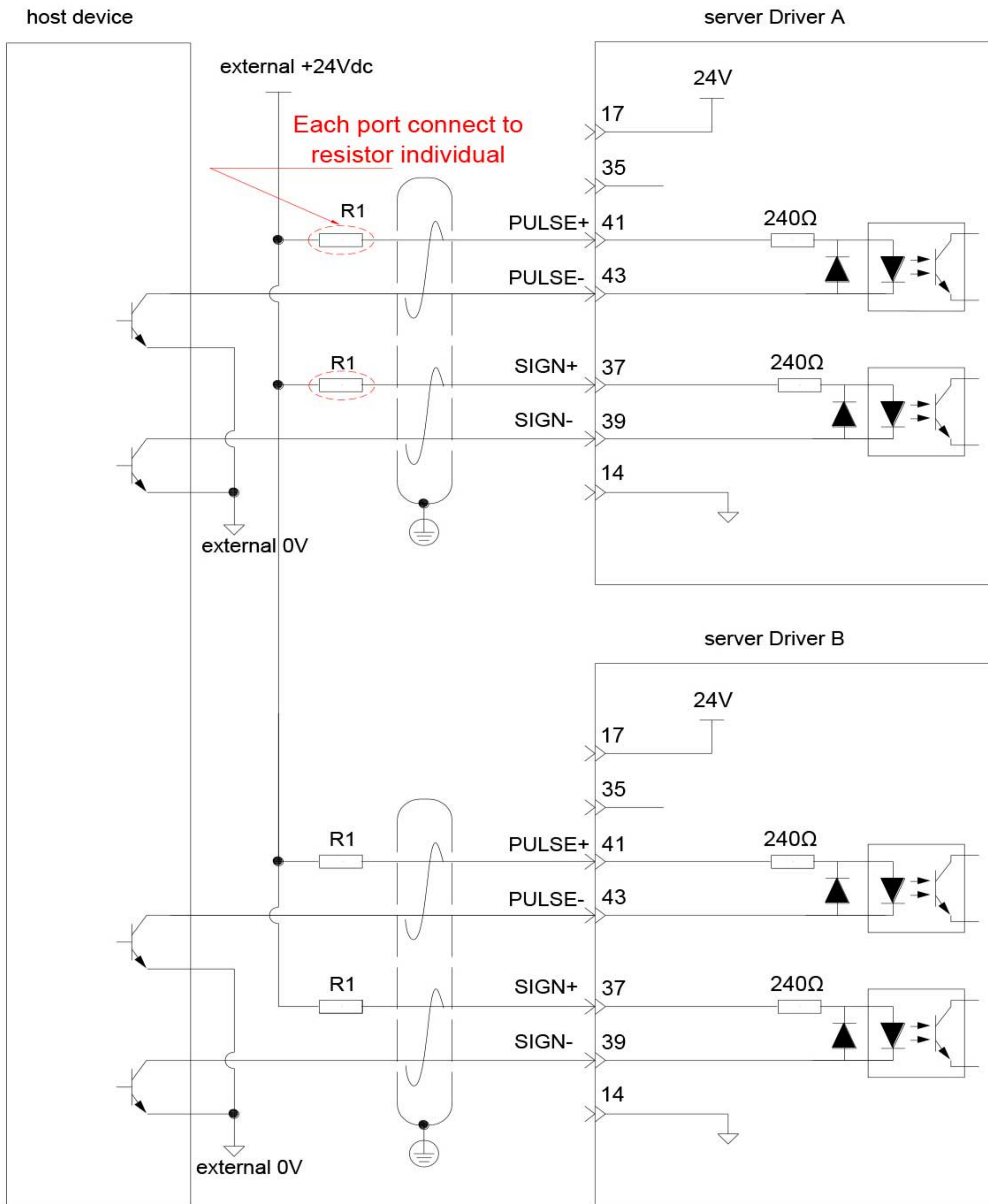

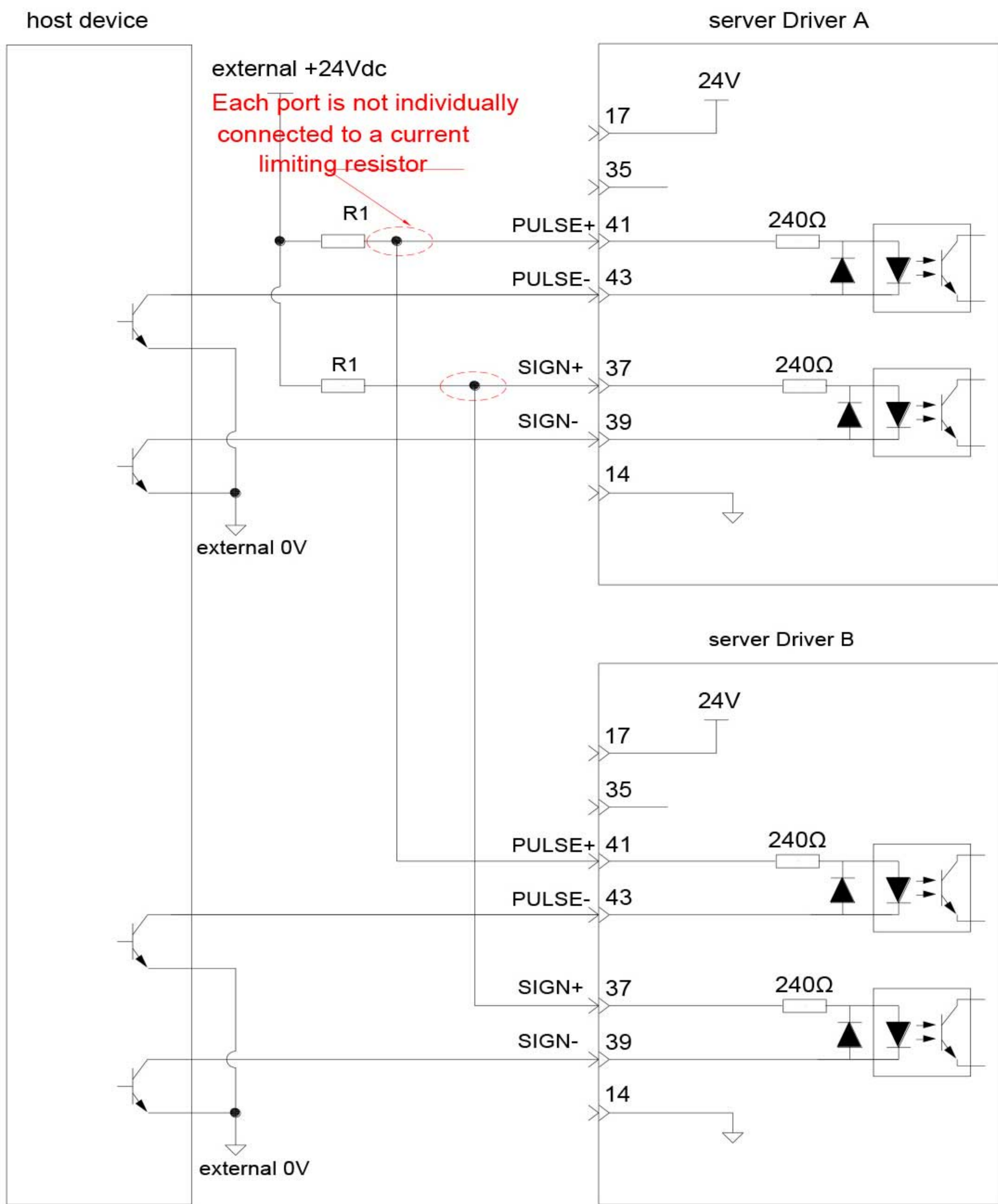

High-speed pulse command input

The high-speed command pulse and symbol output circuit on the host device side can only be output to the servo driver through the differential driver.

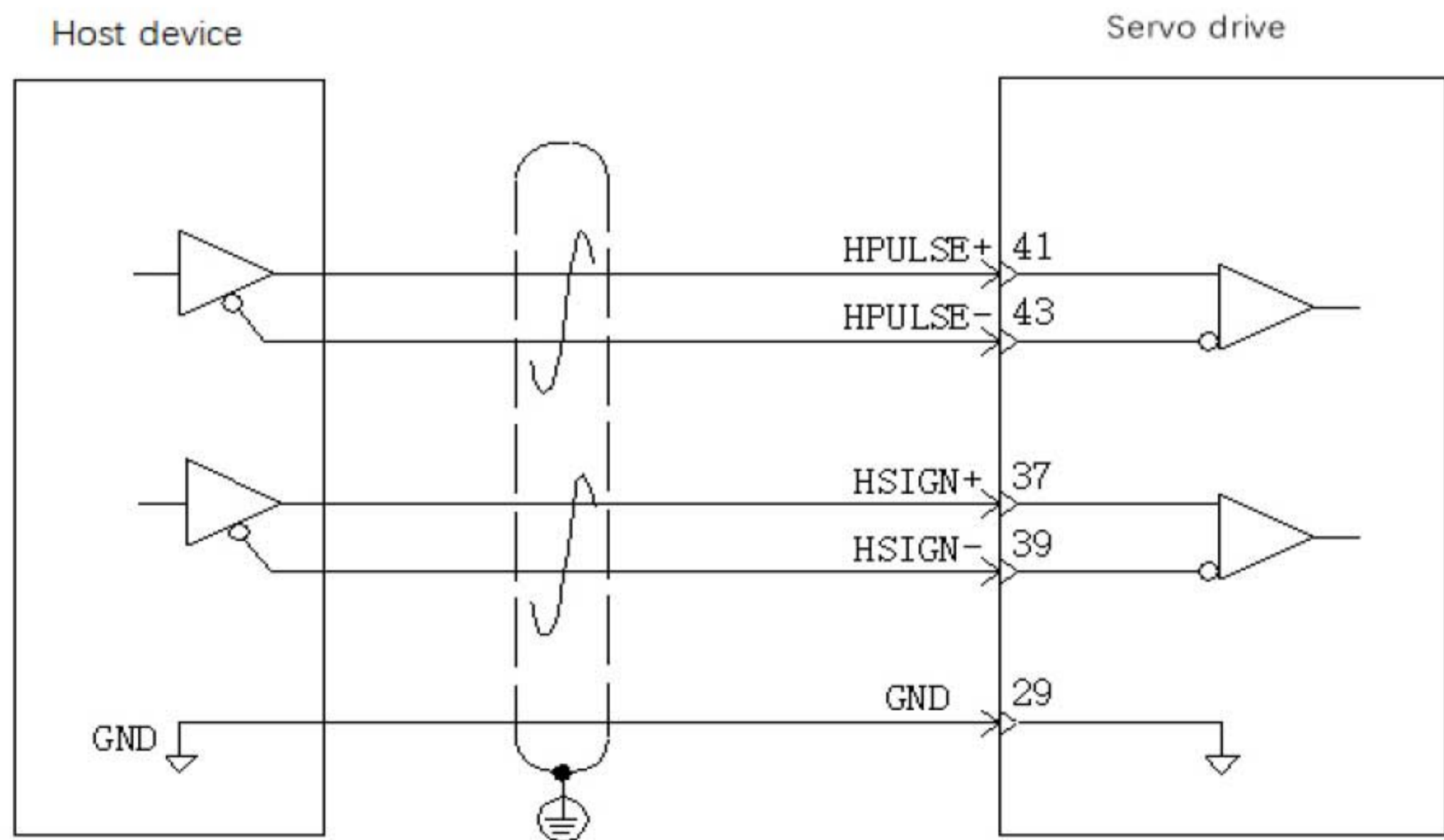



Notes



Please ensure that the differential input is a 5V system, otherwise the input pulse of the servo drive will be unstable, which will lead to the following situations:

- When the command pulse is input, the phenomenon of pulse loss occurs;
- When the direction of the input command is input, the phenomenon of command inversion occurs.

Be sure to connect the 5V ground of the host device to the GND of the driver to reduce noise interference.

3.4.2 Digital input and output signal

Sheet 3-5 DI/DO signal description

Signal	Function	PIN	Function
DI1	P-OT	9	Positive limit switch
DI2	N-OT	10	Negative limit switch
DI3	INHIBIT	34	Pulse input inhibited
DI4	ALM-RST	8	Alarm reset (edge valid)
DI5	S-ON	33	Servo ON
DI8	HomeSwitch	30	Home switch
DI9	keep	12	-
+24V		17	Internal 24 V power supply, voltage range: 20 to 28 V, COM-maximum output current: 200 mA
COM-		14	
COM+		11	Power input (12V~24V)
DO1+	S-RDY+	7	Servo ready
DO1-	S-RDY-	6	
DO2+	COIN+	5	Position reached
DO2-	COIN-	4	
DO3+	ZERO+	3	Zero speed
DO3-	ZERO-	2	
DO4+	ALM+	1	Fault output
DO4-	ALM-	26	
DO5+	HomeAttain+	28	Homing completed
DO5-	HomeAttain-	27	

Digital input circuit

Taking DI1 as an example, the interface circuits of DI1~DI9 are the

same. 1) When the host device is a relay output:

a) When using the internal 24V power supply of the servo drive:

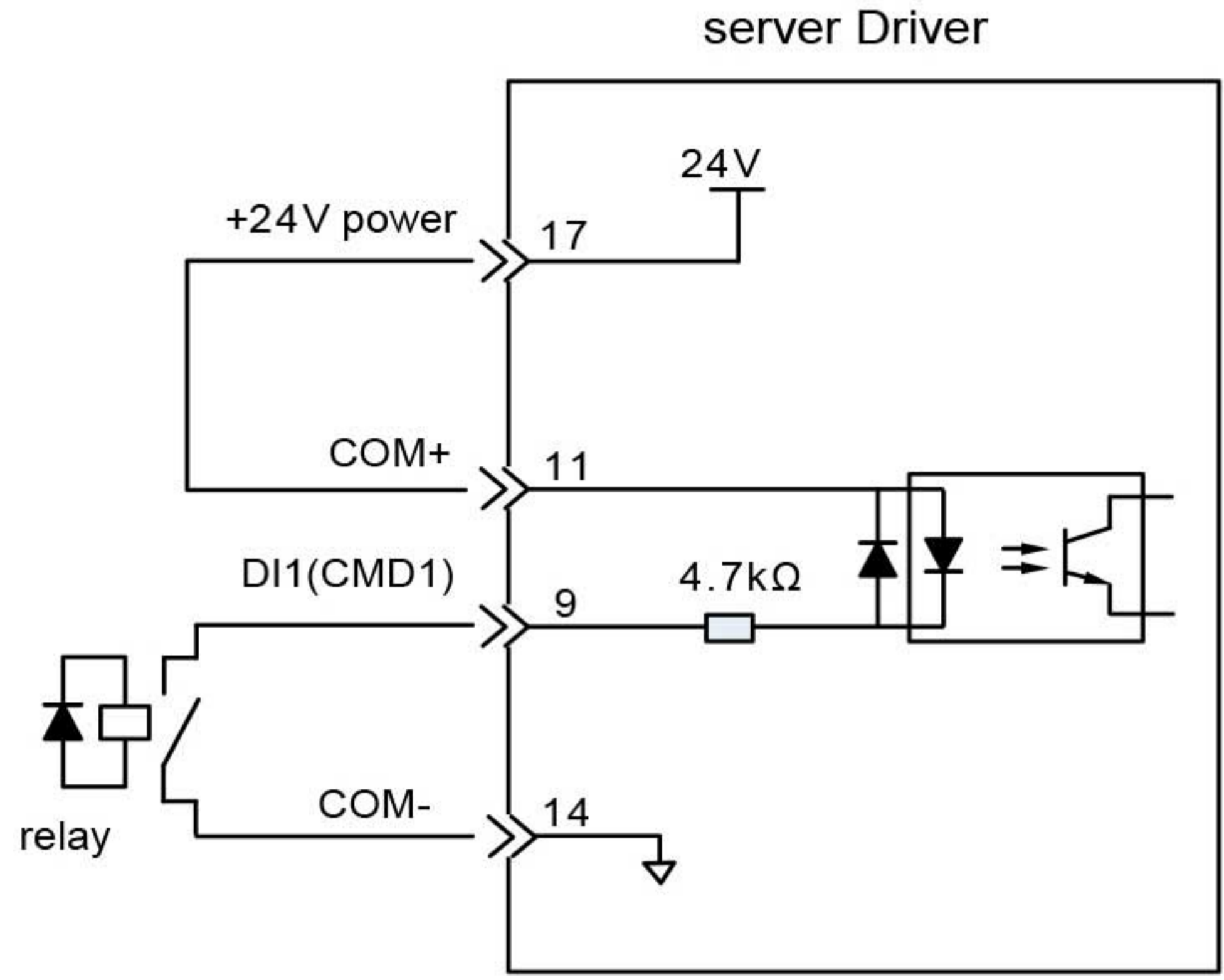

b) When using an external power supply:

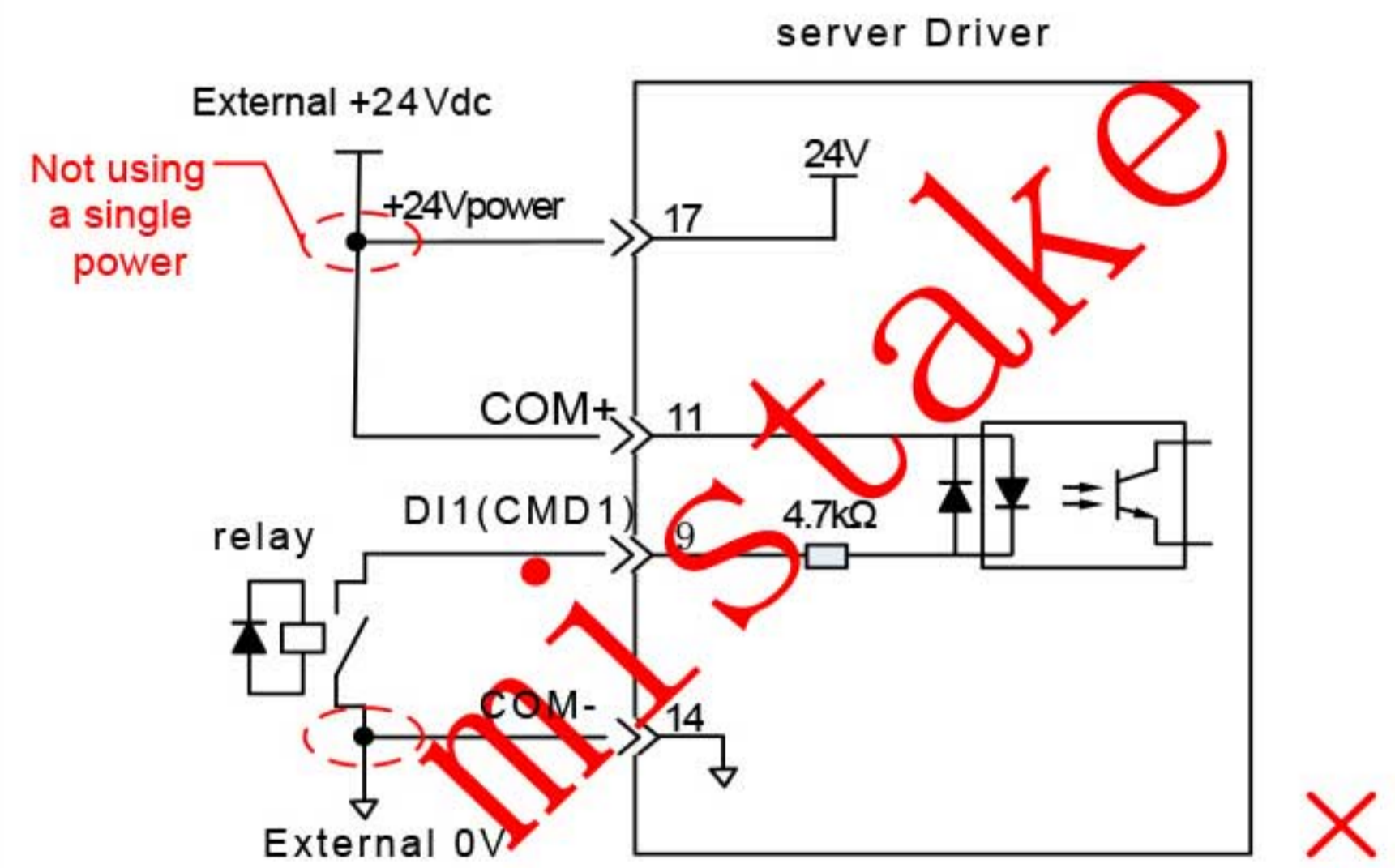
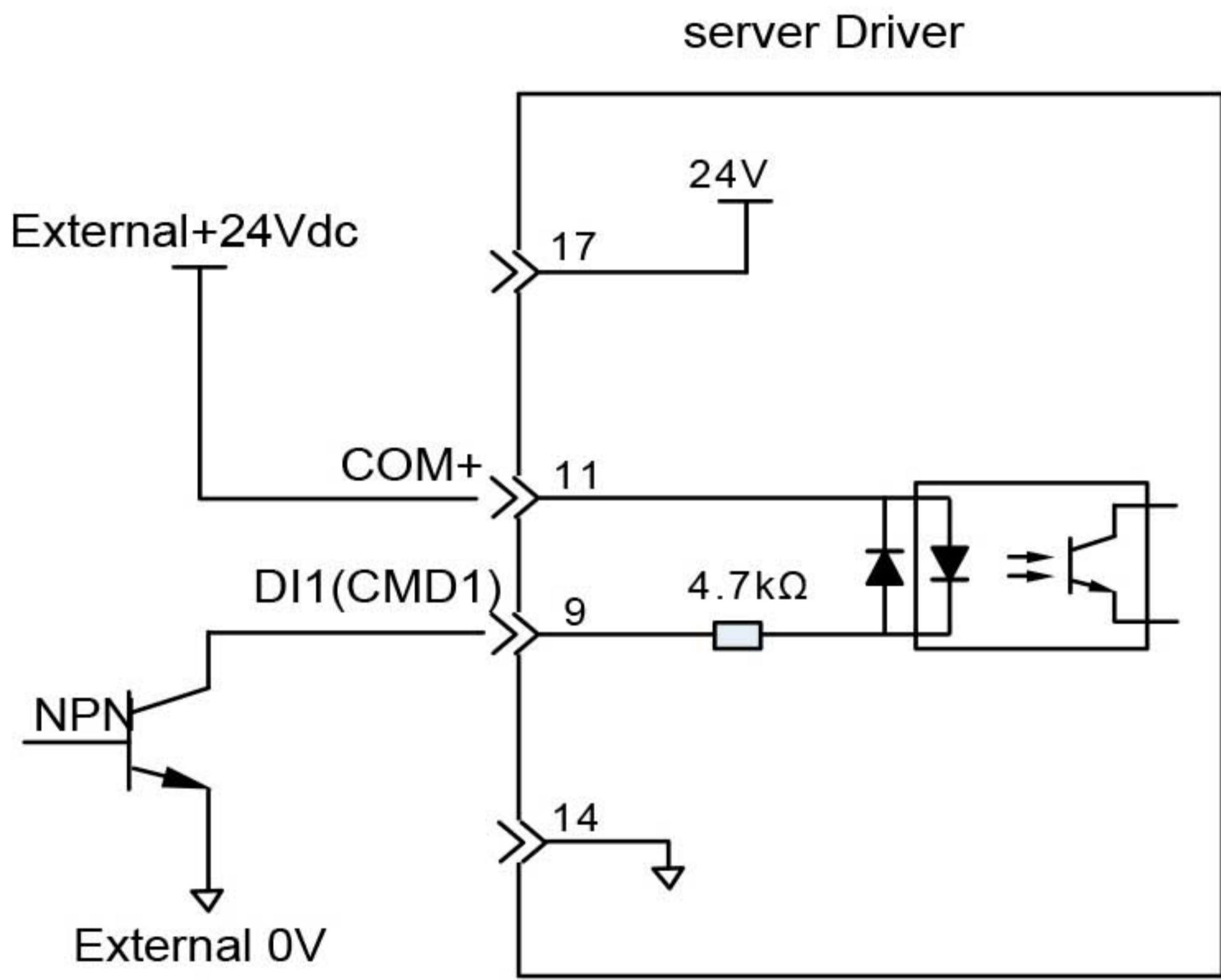

2) When the host device is open collector output:

a) When using the internal 24V power supply of the servo drive:

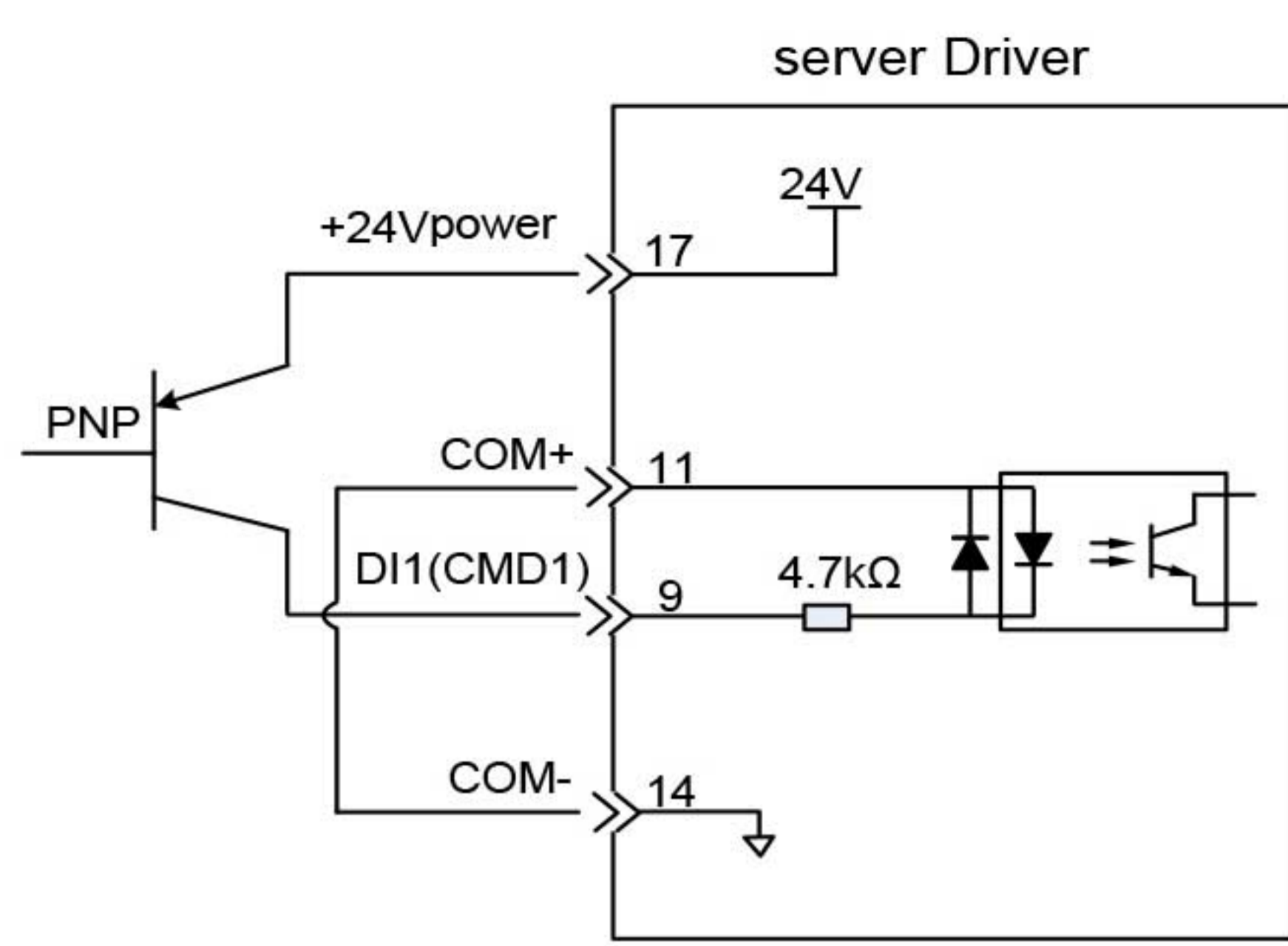
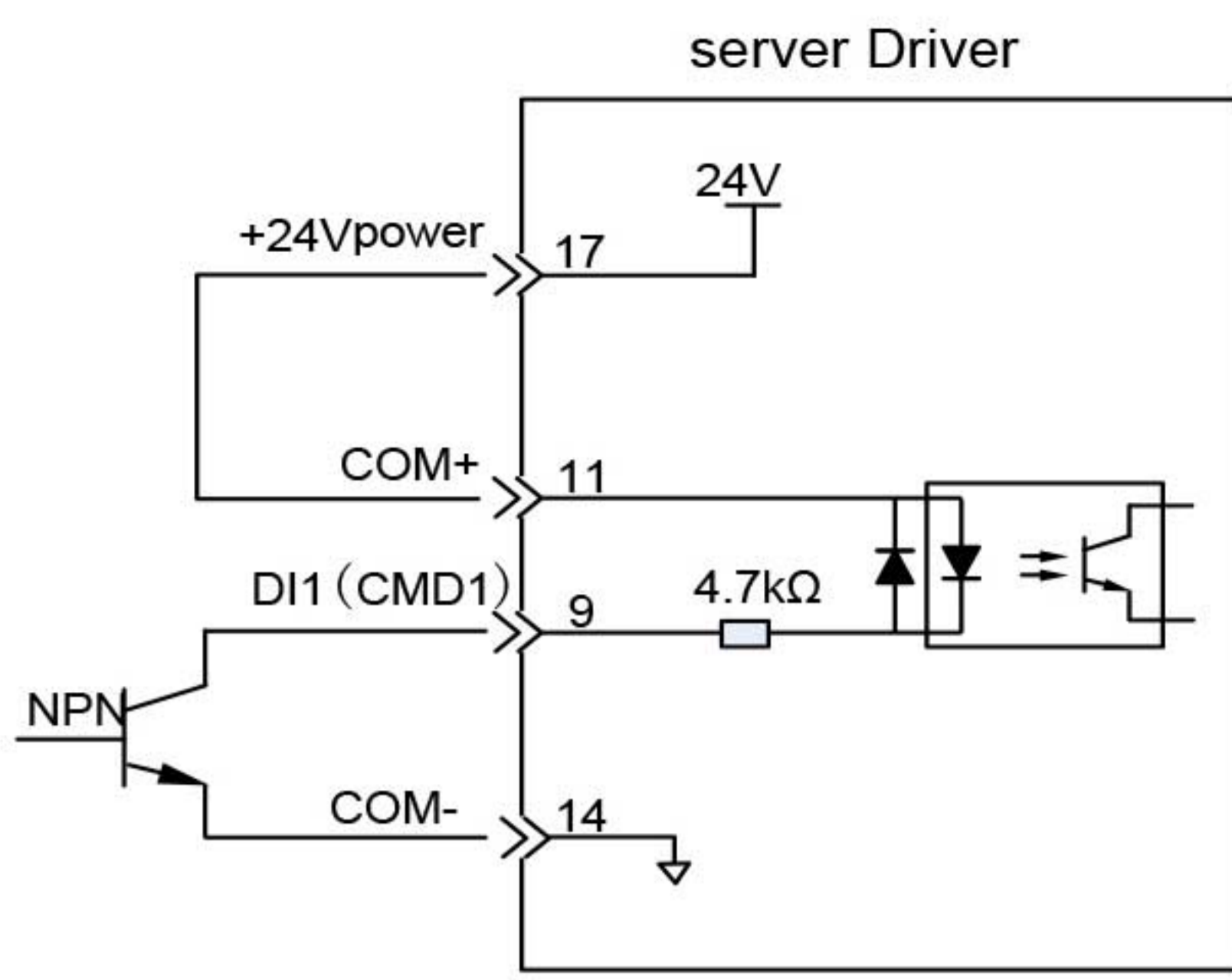

b) When using an external power supply

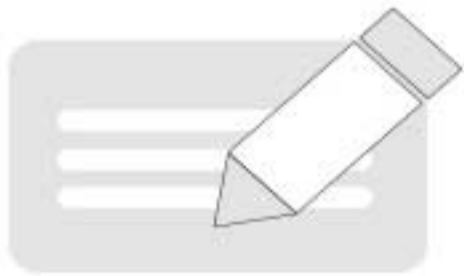
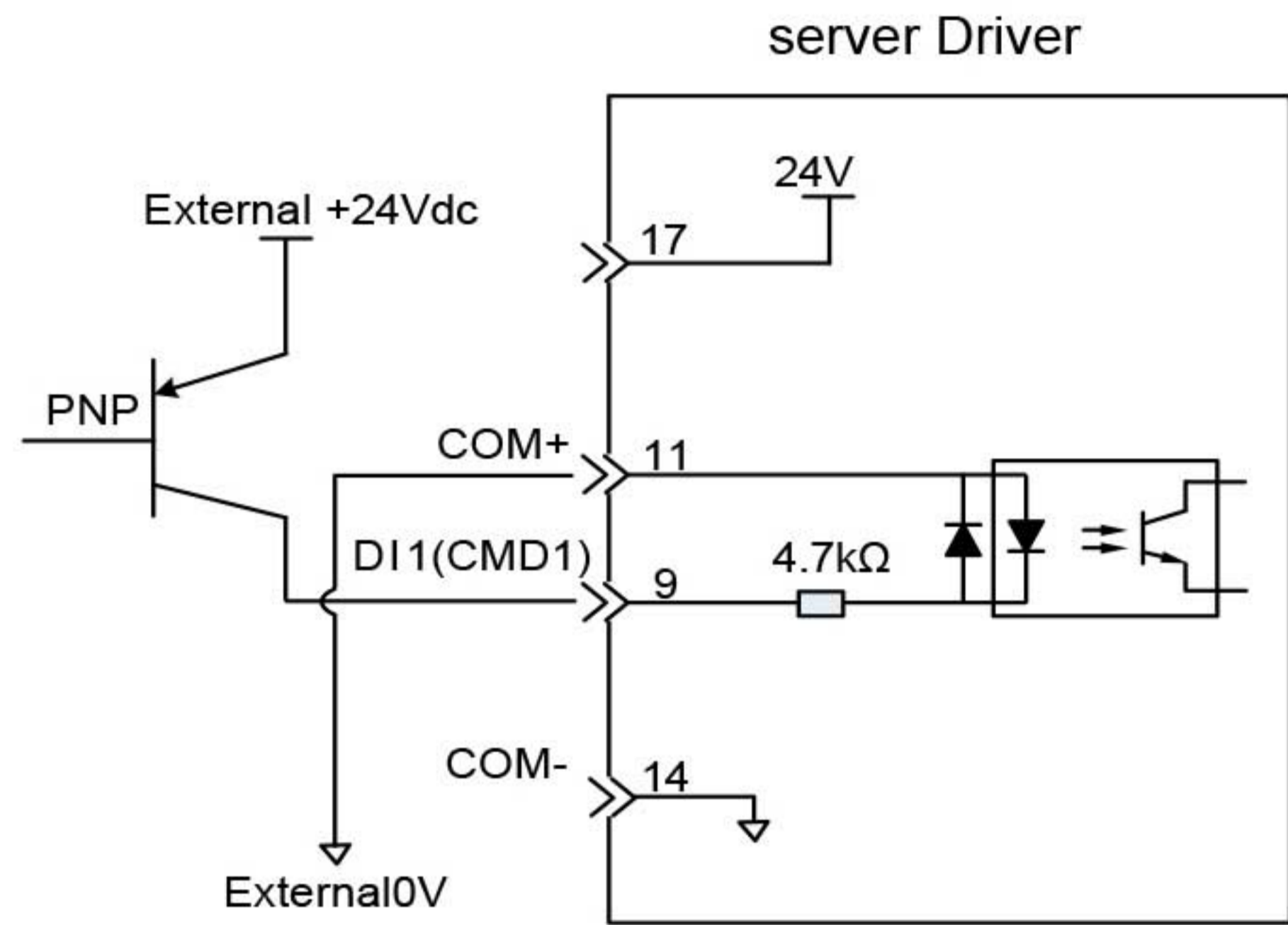
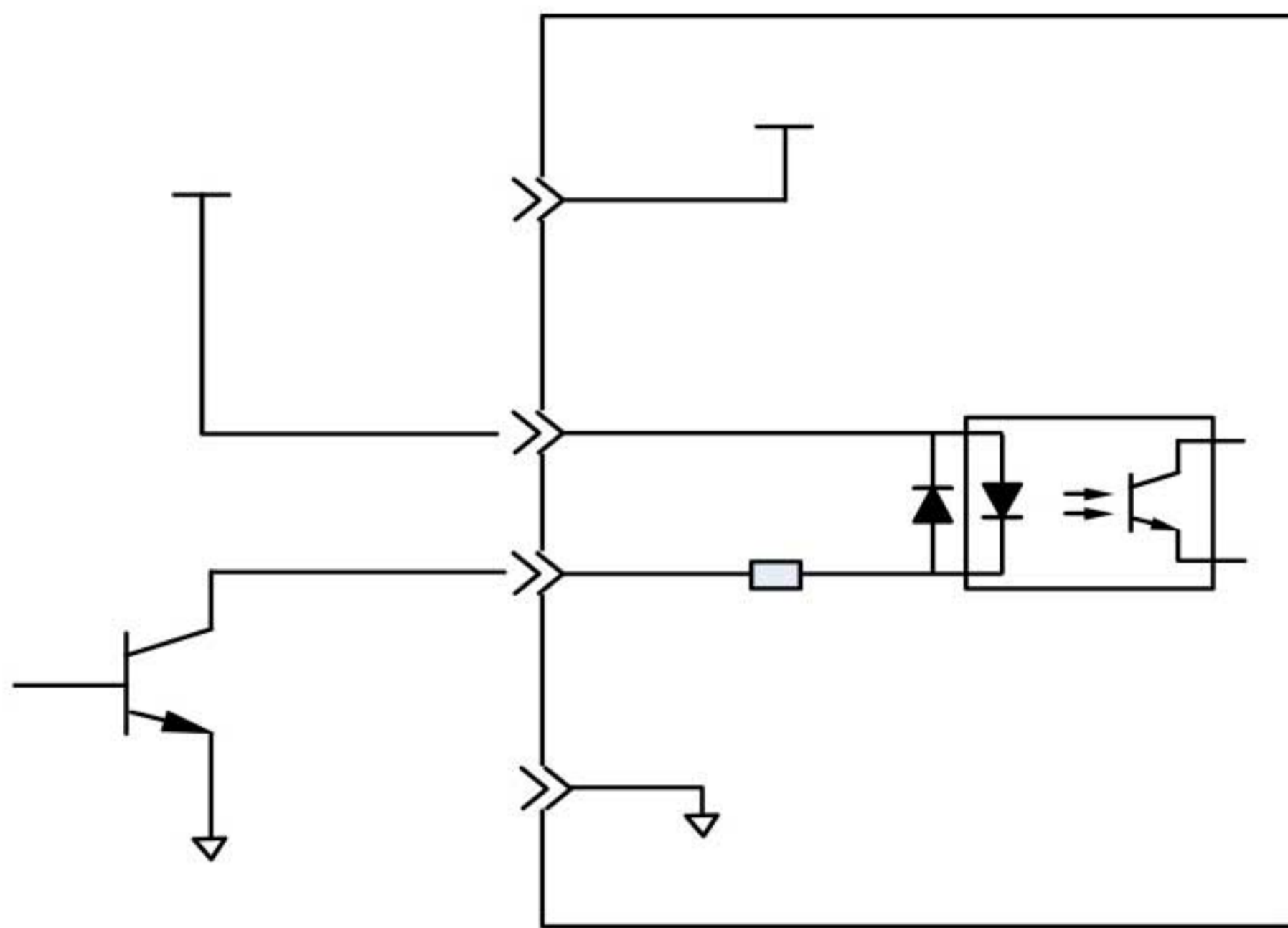

◆ Mixing of PNP and NPN inputs is not supported.

2. Digital output circuit

Taking DO1 as an example, the interface circuits of DO1 to DO5 are the same.

1) When the host device is a relay input:

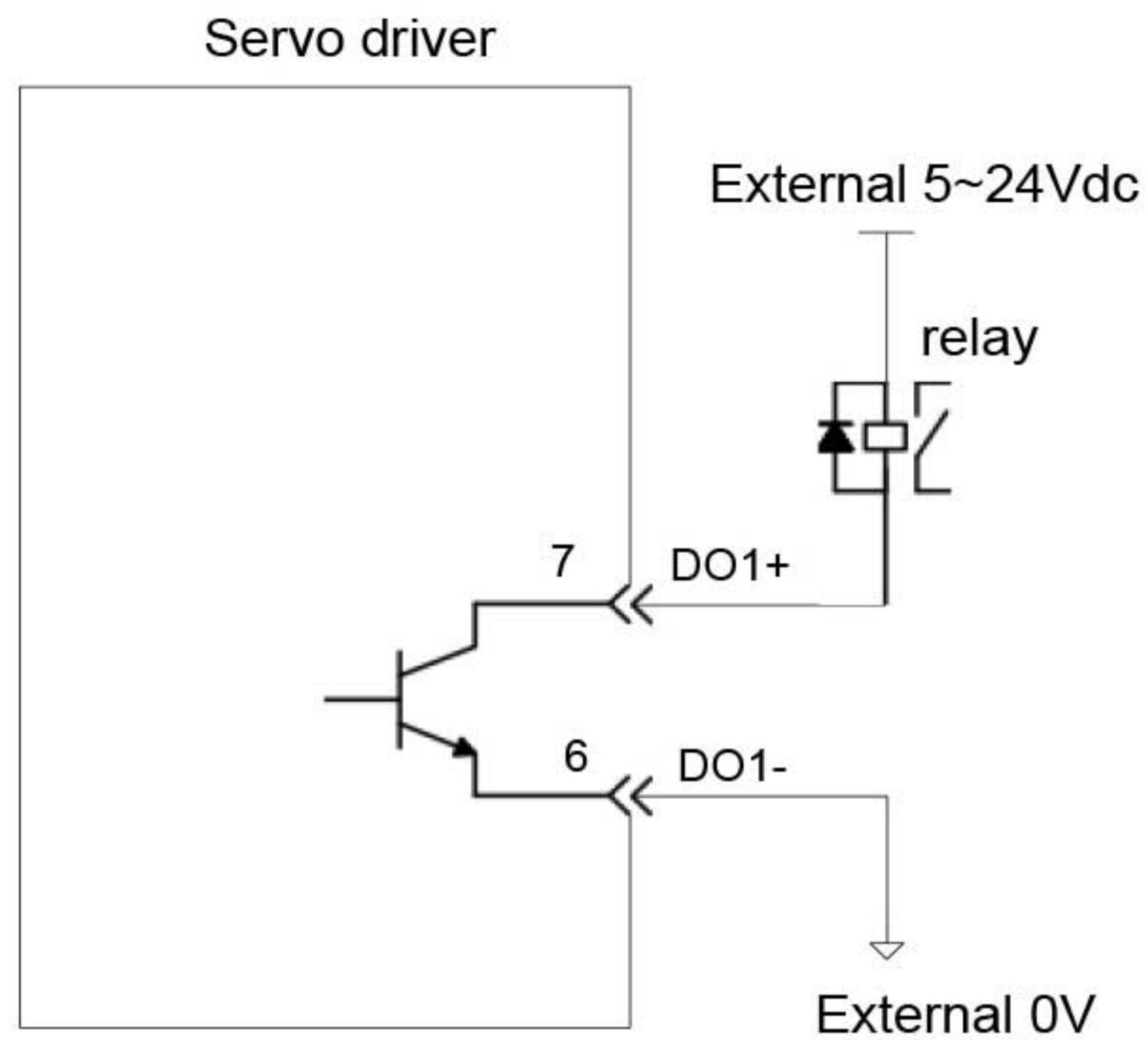

- ◆ When the upper-level device is a relay input, be sure to connect a freewheeling diode, otherwise the DO port may be damaged.

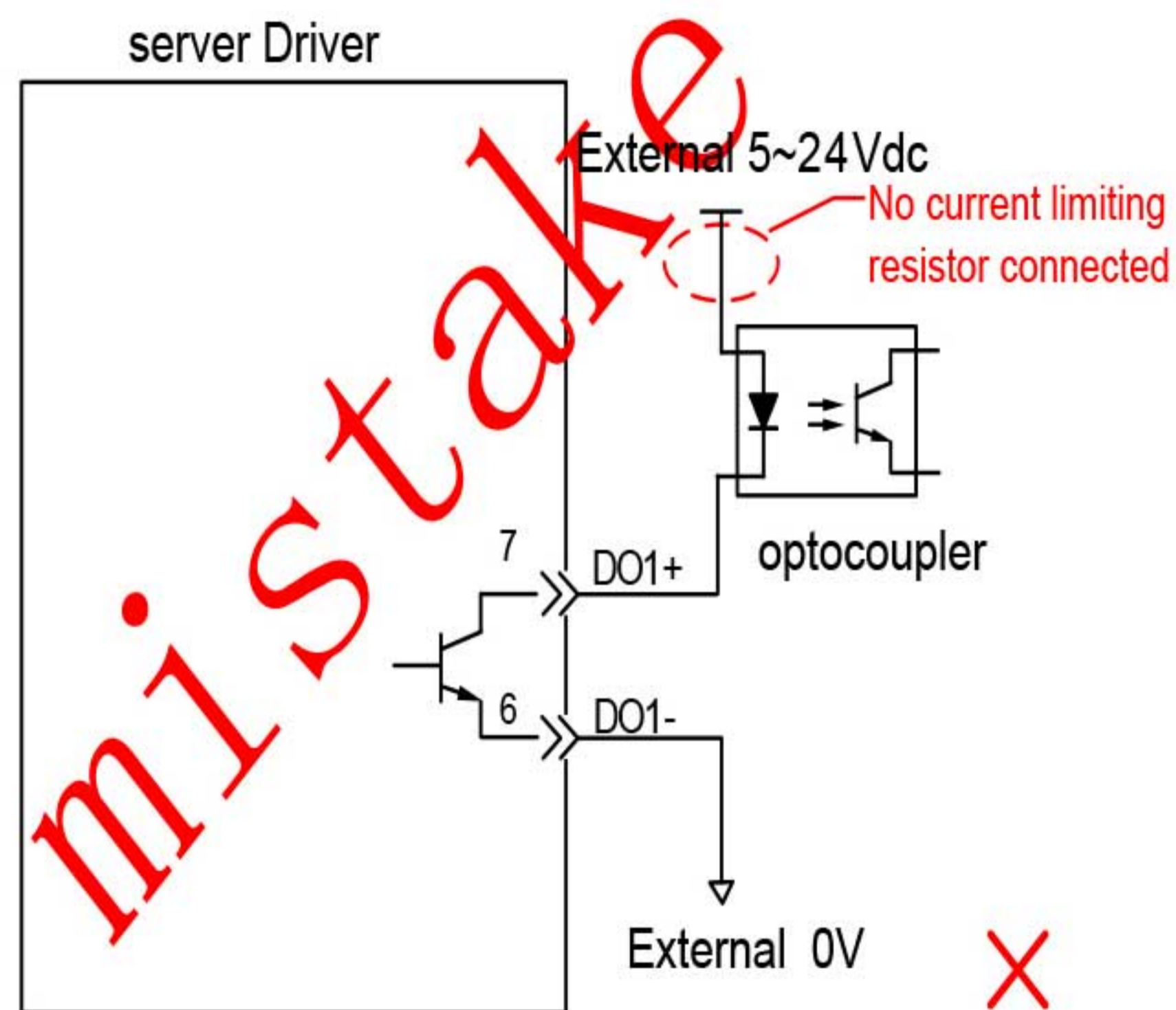
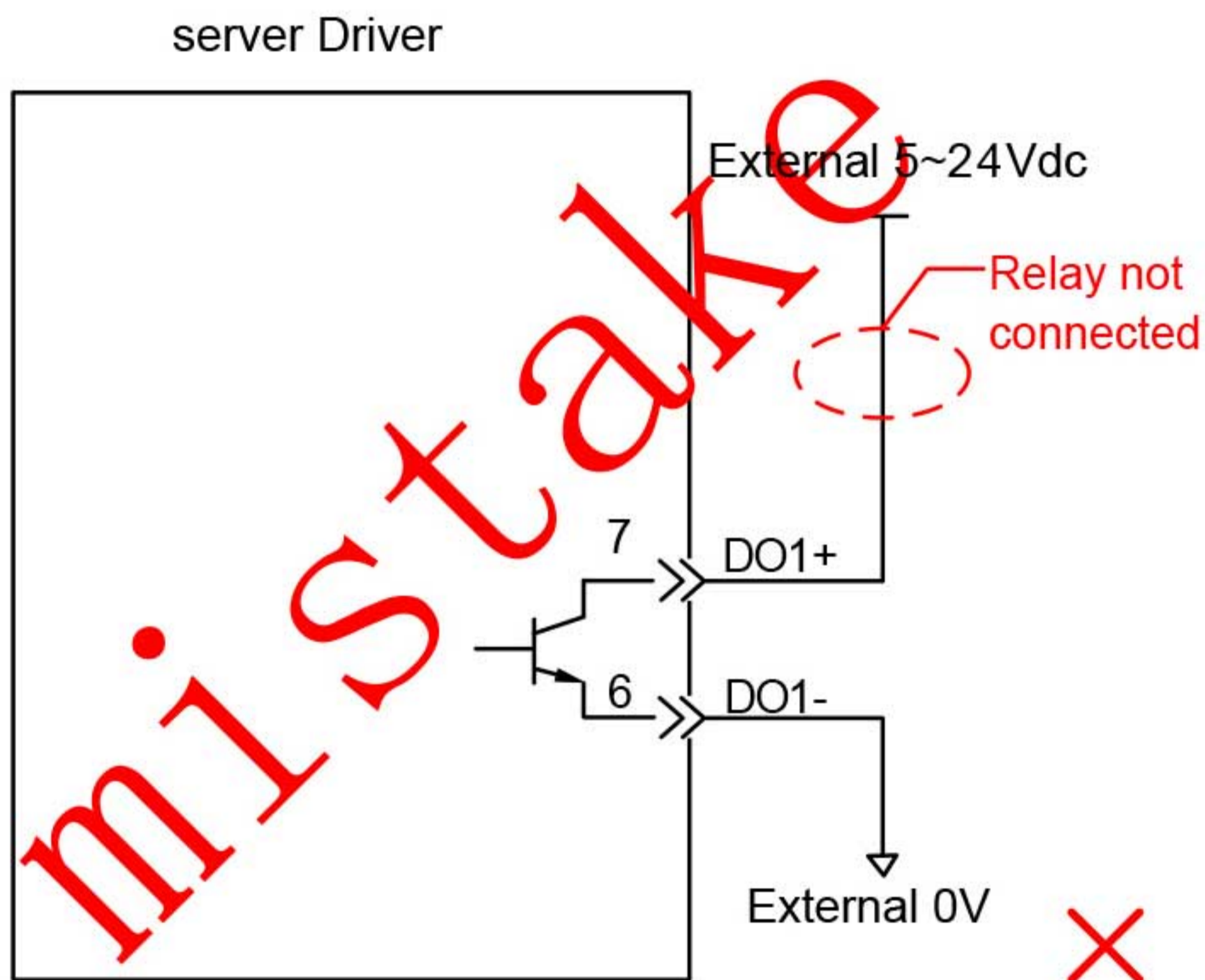

2)When the host device is optocoupler input:

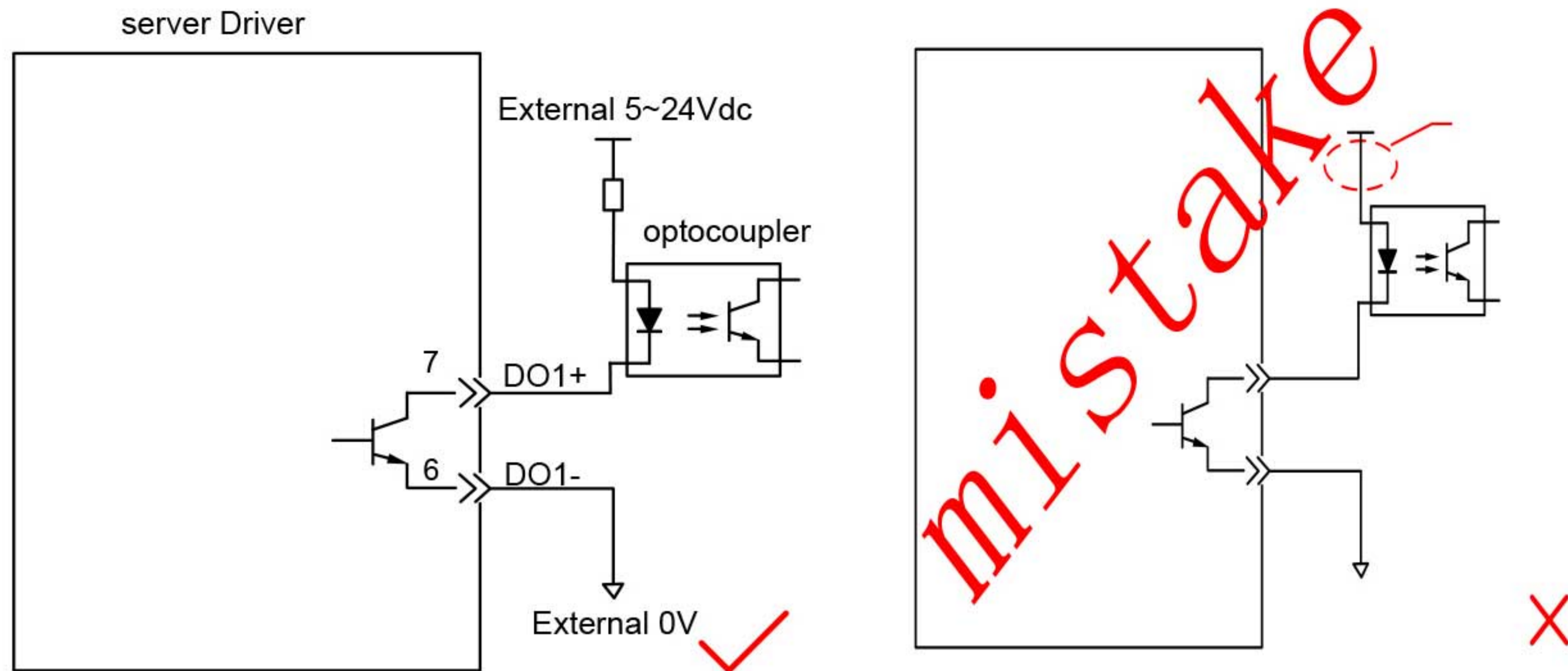

The maximum allowable voltage and current capacity of the optocoupler output circuit inside the servo drive are as follows

- voltage: DC30V(max)
- current: DC50mA(max)

3.4.3 Encoder Frequency-Division Output Signal

Sheet 3-6 Encoder Frequency-Division Output Signal

Signal	Default Function	Pin No.	Function Description	
General	PAO+ PAO-	21 22	PhaseAoutput signal	PhasesA+B quadrature pulse output signal
	PBO+ PBO-	25 23	Phase B output signal	
	PZO+ PZO-	13 24	Phase Z output signal	Home pulse output signal
	PZ-OUT	44	Phase Z output signal	Home pulse OC output signal
	GND	29	Home pulse OC output signal ground	
	+5V	15	5 V internal power supply Maximum output current: 200 mA	
	GND	16		
	PE	Housing	-	

The encoder frequency-division output circuit outputs OC signals via the differential drive. Generally, it provides feedback signals to the host controller in the closed-loop position control system. A differential or optocoupler circuit shall be used in controller to receive feedback signals. The maximum output current is 20mA.

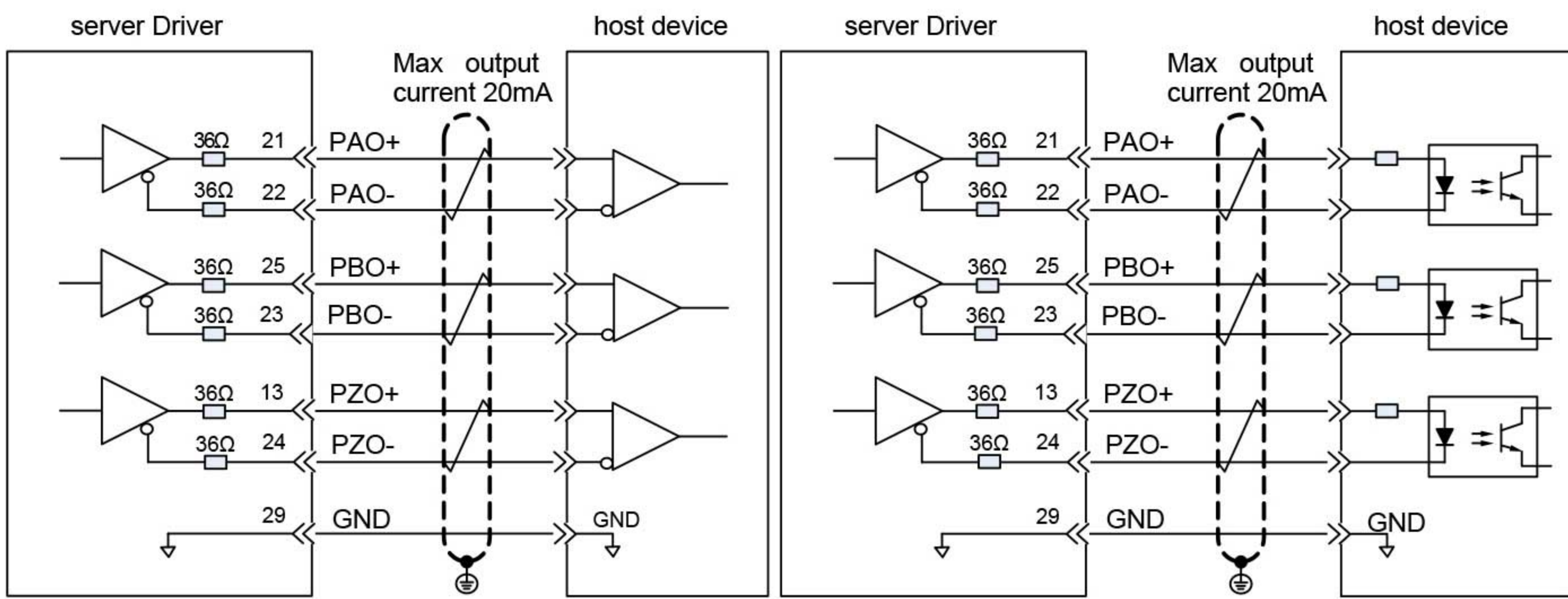

The encoder Z-phase frequency division output circuit can pass the open-collector signal. Usually, feedback signals are provided when a position control system is formed for a host device. On the host device side, please use a photocoupler circuit, a relay circuit or a bus receiver circuit to receive.

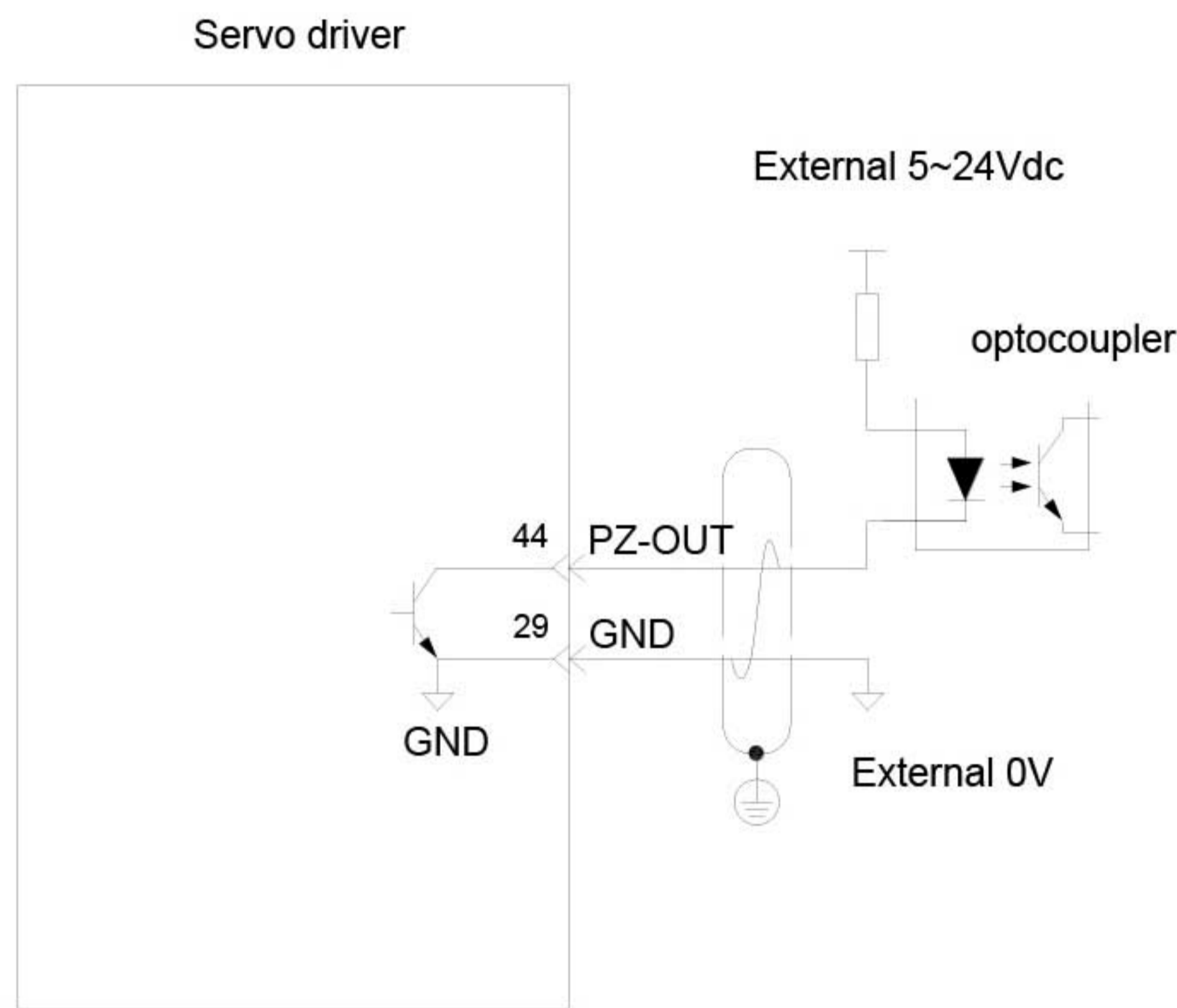

Notes

- ◆ Be sure to connect the 5V ground of the host device to the GND of the driver, and use a twisted pair shielded wire to reduce noise interference.

The maximum allowable voltage and current capacity of the optocoupler output circuit inside the servo drive are as follows:

- voltage: DC30V(max)
- current: DC50mA(max)

3.4.4 Brake wiring

The holding brake is a mechanism that prevents the servo motor shaft from moving and keeps the motor locked in position when the servo drive is in a non-operational state, so that the moving part of the machine will not move due to its own weight or external force.

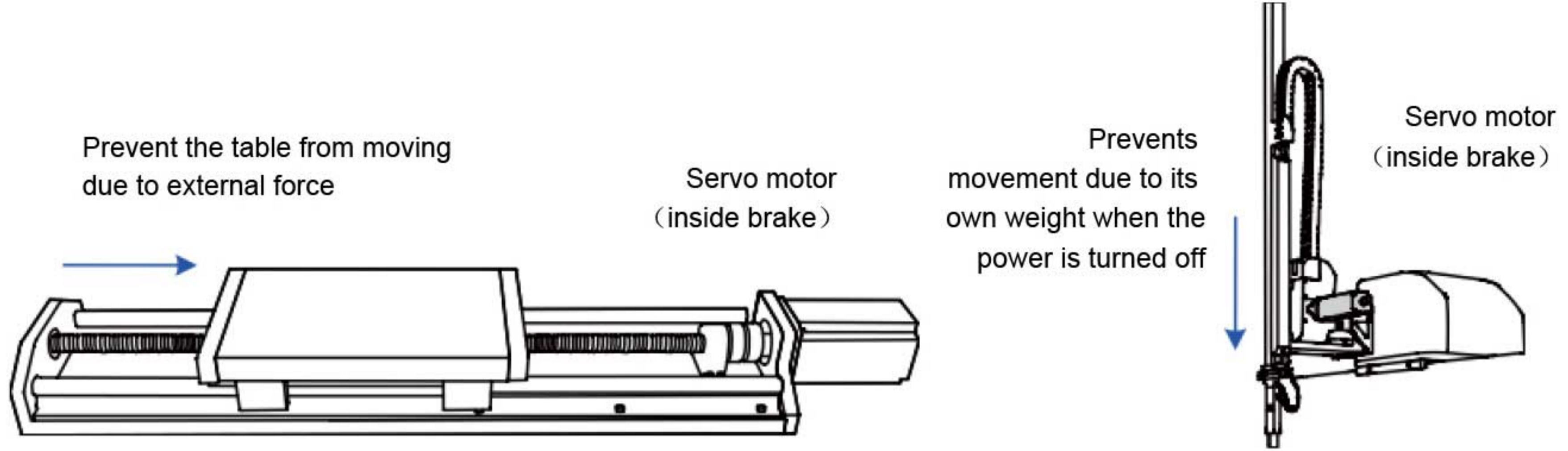

Figure 3-4 Brake application diagram

⚠ Notes	
⚠	<ul style="list-style-type: none"> ◆ The holding brake mechanism built into the servo motor is a non-energized fixed special mechanism, which cannot be used for braking purposes, and is only used to keep the servo motor in a stopped state. ◆ The brake coil has no polarity. ◆ After the servo motor stops, the servo enable (S-ON) should be turned off. ◆ When the motor with built-in brake is running, the brake may make a clicking sound, but the function is not affected. ◆ When the brake coil is energized (the brake is open), magnetic flux leakage may occur at the shaft end, etc. Be careful when using instruments such as magnetic sensors near the motor.

Brake wiring

The connection of the brake input signal has no polarity, and the user needs to prepare a 24V power supply. The standard wiring example of the brake signal BK and the brake power supply is as follows:

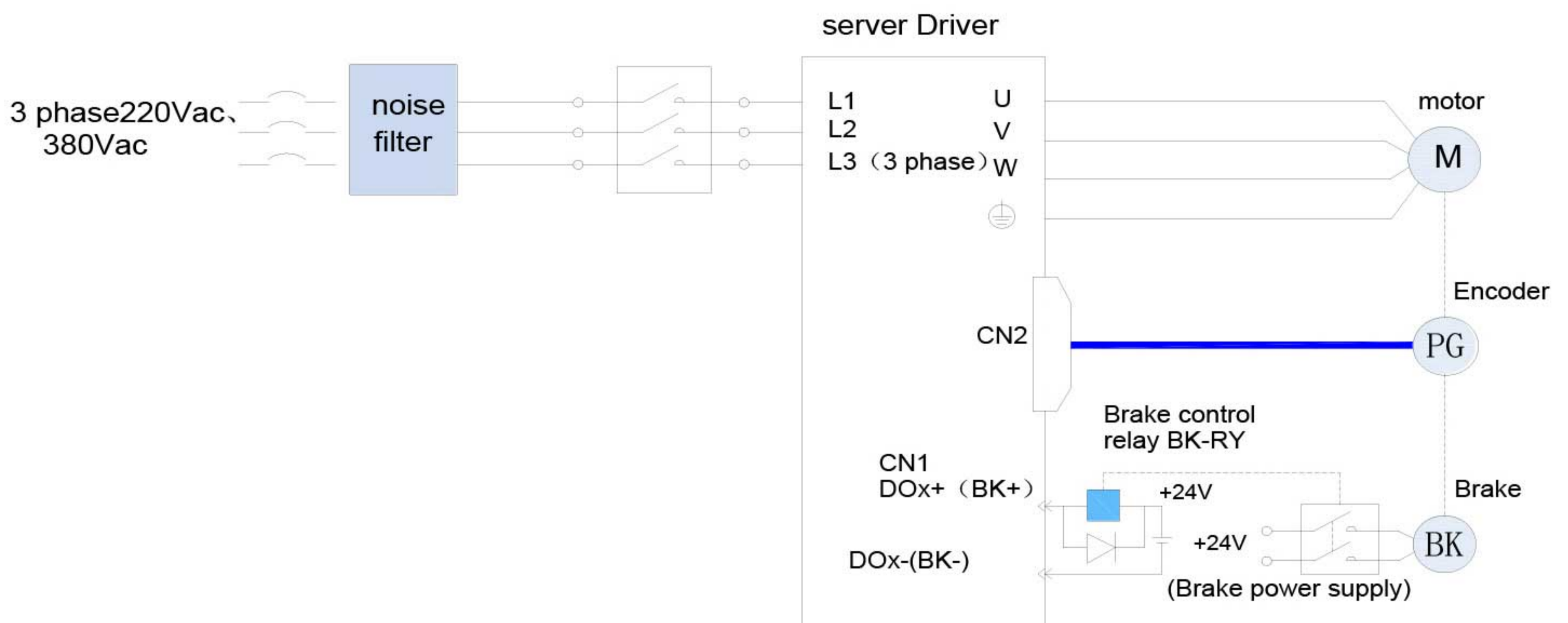

Figure 3-5 Brake wiring

Brake wiring precautions:

- The holding brake is forbidden to share the power supply with other electrical appliances to prevent the voltage or current from being reduced due to the work of other electrical appliances, which will eventually lead to the malfunction of the holding brake.
- It is recommended to use a cable of 0.5mm² or more.

3.5 Comm. CN3/CN4 cable

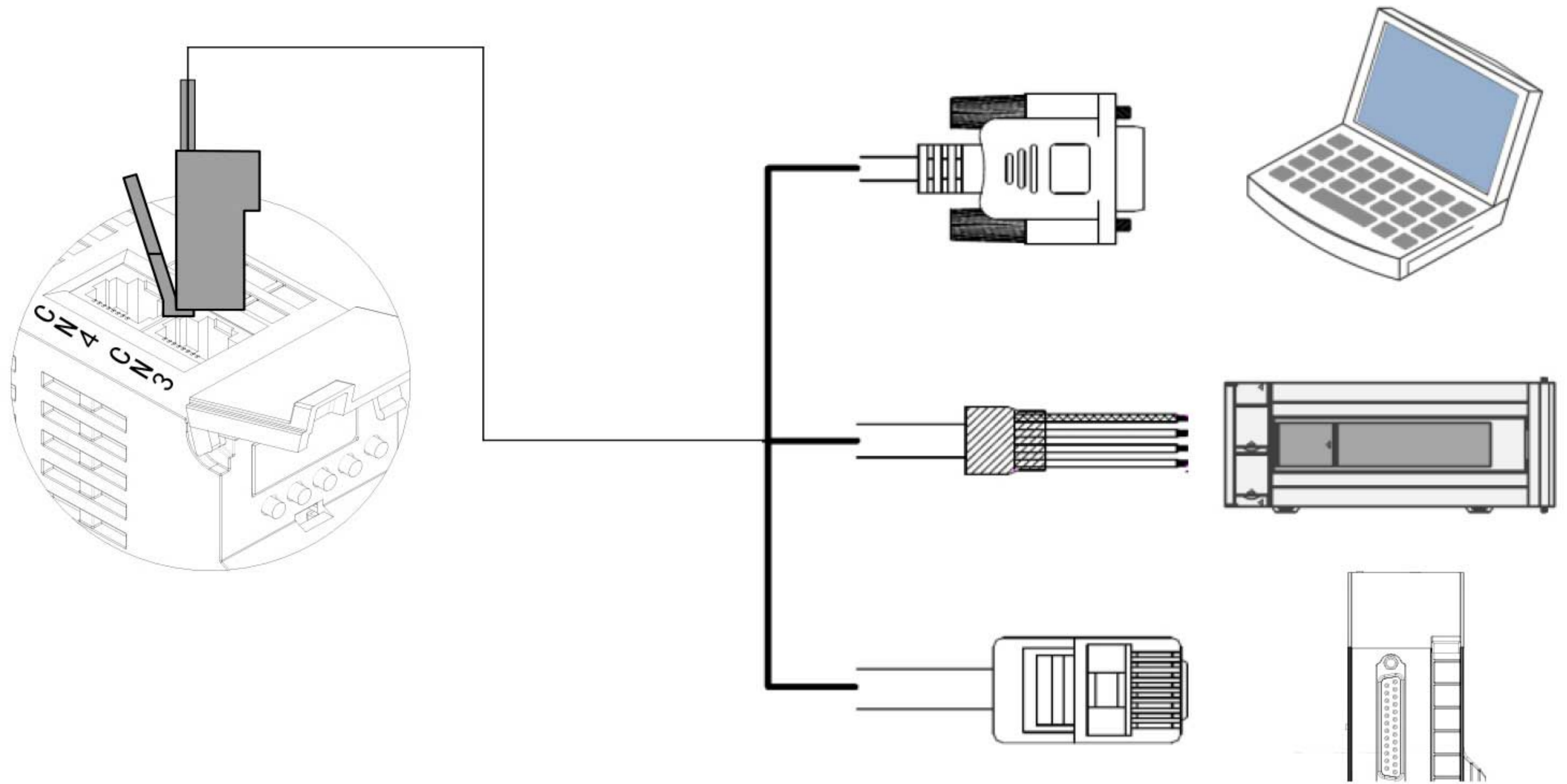

Figure 3-6 Communication wiring diagram

The communication signal connectors (CN3, CN4) are two identical communication signal connectors connected in parallel internally.

Pin No.	Definition	Description	Pin Layout
1	CANH	CAN communication port	
2	CANL		
3	GND	CAN communication ground	
4	RS485+	RS485 communication port	
5	RS485-		
6	RS232-TXD	RS232 transmitting end, connected to the receiving end of the host controller	
7	RS232-RXD	RS232 transmitting end, connected to the sending end of the host controller	
8	GND	Ground	
Housing	PE	Shield	

3.5.1 CAN Communication networking connection

1. CAN communication connection with PLC

When the CAN communication network is used, the connection cable between the driver and the PLC is as follows:

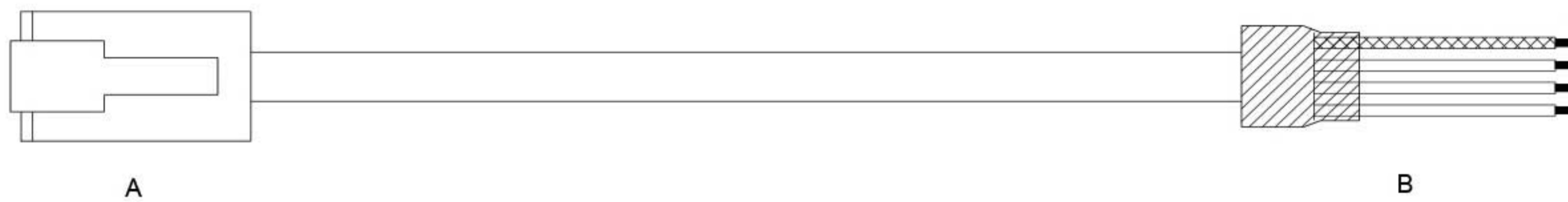

Figure 3-7 Appearance example of PLC and servo communication cables

Sheet 3-7 PLC and servo communication cable pin connection relationship

Servo drive side RJ45 (A terminal)			PLC side (B terminal)		
Comm.type	Signal name	Pin No.	Comm.type	Signal name	Pin No.
CAN	CANH	1	CAN	CANH	1
	CANL	2		CANL	2
	CGND	3		CGND	3
	PE (Shielded network layer)	Housing		PE (Shielded network layer)	Housing

CAN communication connection of multiple machines in parallel

When the CAN communication network is used, the connection cables of multiple drives in parallel are as follows:

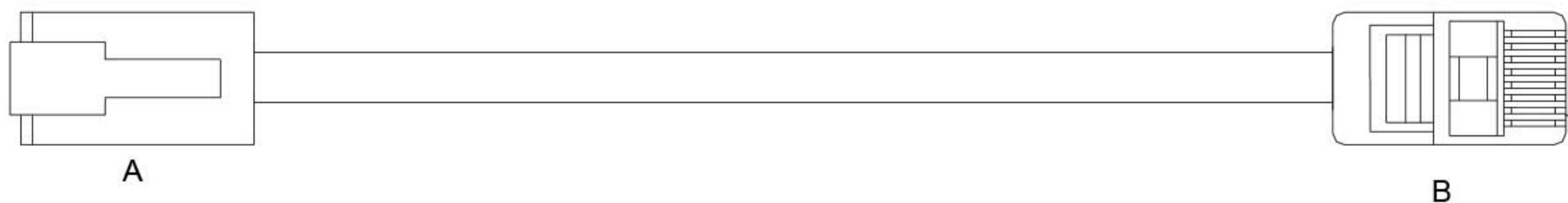

Figure 3-8 Appearance example diagram of multi-machine parallel communication cable

Sheet 3-8 Multi-machine parallel communication cable pin connection relationship

Servo drive RJ45 (A side)			Servo drive RJ45 (B side)		
Comm.type	Signal	Pin No.	Comm.type	Signal	Pin No.
CAN	CANH	1	CAN	CANH	1
	CANL	2		CANL	2
	CGND	3		CGND	3
	PE Shielded network layer	Housing		PE (Shielded network layer)	Housing

CAN Communication grounding precautions

When using CAN communication, pay attention to the connection between the CGND terminal of the host device and the CGND terminal of the servo drive, as shown in the figure below:

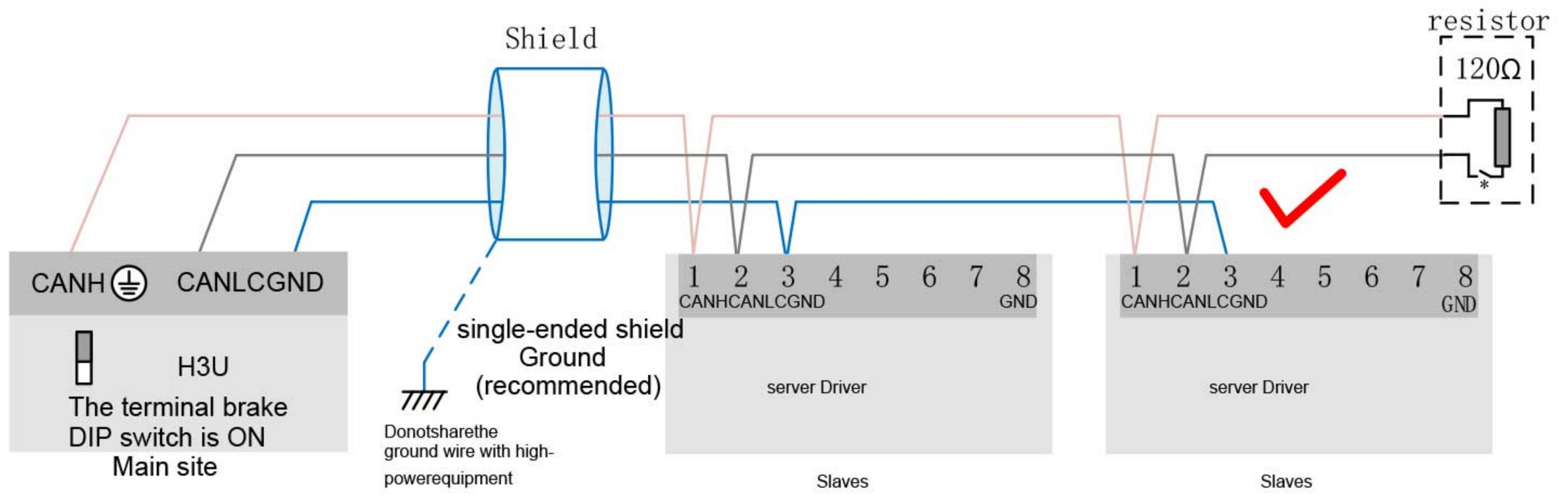

Figure 3-9 correct CAN connection way

⚠ Notes	
⚠	<ul style="list-style-type: none"> ● PLC built-in CAN communication terminal resistance, the corresponding DIP switch must be set to ON; ● It is recommended that the shielding layer be grounded at one end; ● Do not connect the CGND terminal of the upper device to the GND terminal of the servo drive, otherwise the machine will be damaged!

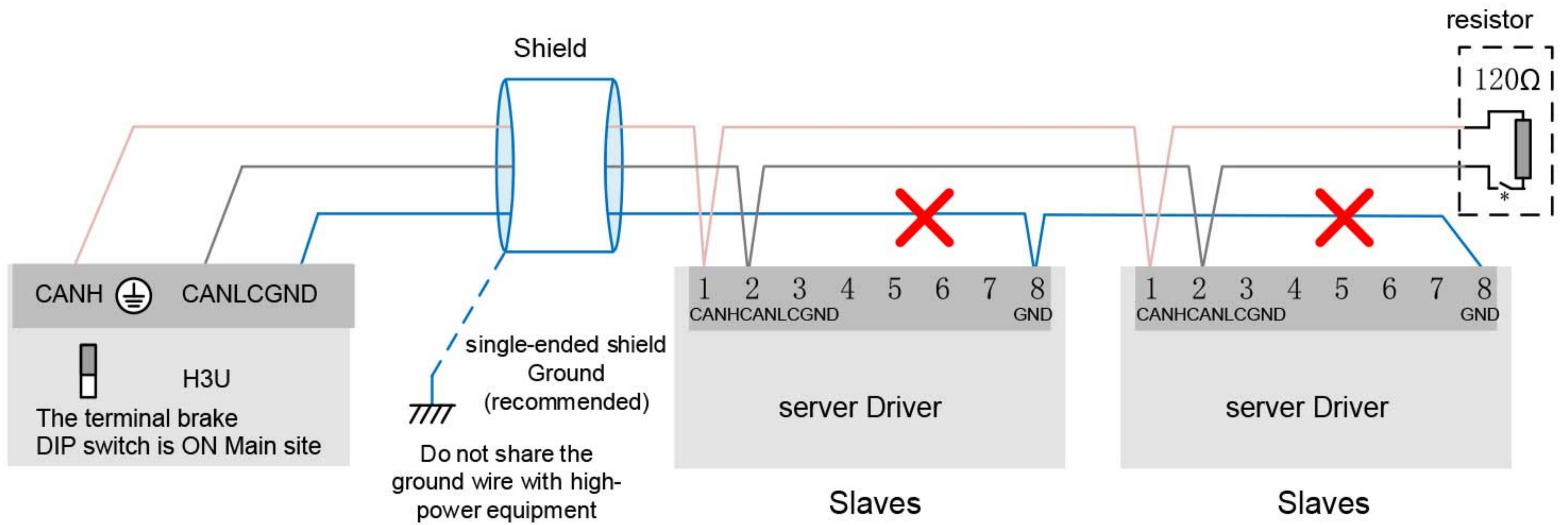

Figure 3-10 wrong CAN connection way

3.5.2 RS485 Comm. Connect way

1. 485 communication connection with PLC

When using the 485 communication network, the connection cables between the drive and the PLC are as follows:

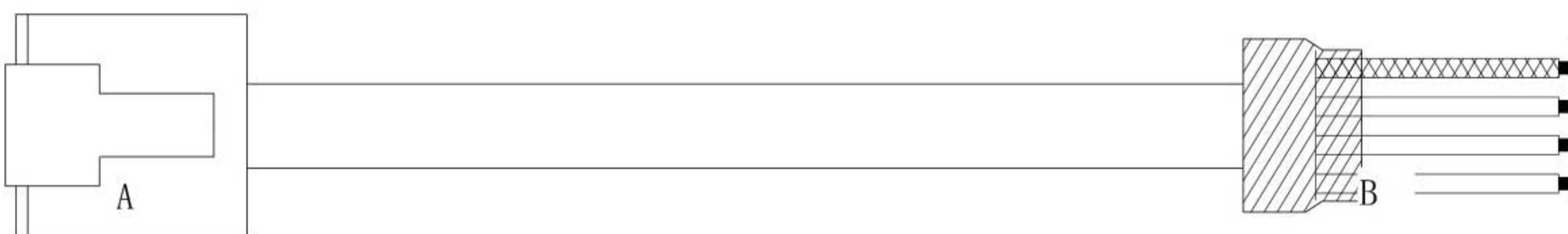

Figure 3-11 Appearance example of PLC and servo communication cables

Servo drive RJ45 (A terminal)			PLC side (B terminal)		
Comm. type	Signal	Pin No.	Comm. type	Signal	Pin No.
RS485	RS485+	4	RS485	RS485+	4
	RS485-	5		RS485-	5
	GND	8		GND	8
	PE (Shielded network layer)	Housing		PE (Shielded network layer)	Housing

2.485 communication connection of multiple machines in parallel

When using 485 communication network, the connection cables of multiple drives in parallel are as follows:

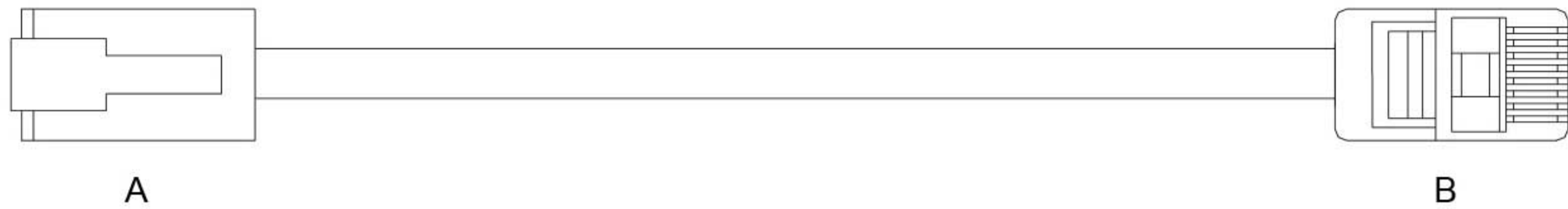

Figure 3-12 Appearance example diagram of multi-machine parallel communication cable

Sheet 3-10 Multi-machine parallel communication cable pin connection relationship

Servo drive RJ45 (A terminal)			Servo drive RJ45 (B terminal)		
Comm. type	Signal	Pin No.	Comm. type	Signal	Pin No.
RS485	RS485+	4	RS485	RS485+	4
	RS485-	5		RS485-	5
	GND	8		GND	8
	PE (Shielded network layer)	Housing		PE (Shielded network layer)	Housing

3. Precautions for CAN communication grounding

When using RS485 communication, pay attention to the connection between the (GND) terminal of the host device and the GND terminal of the servo drive, as shown in the figure below:

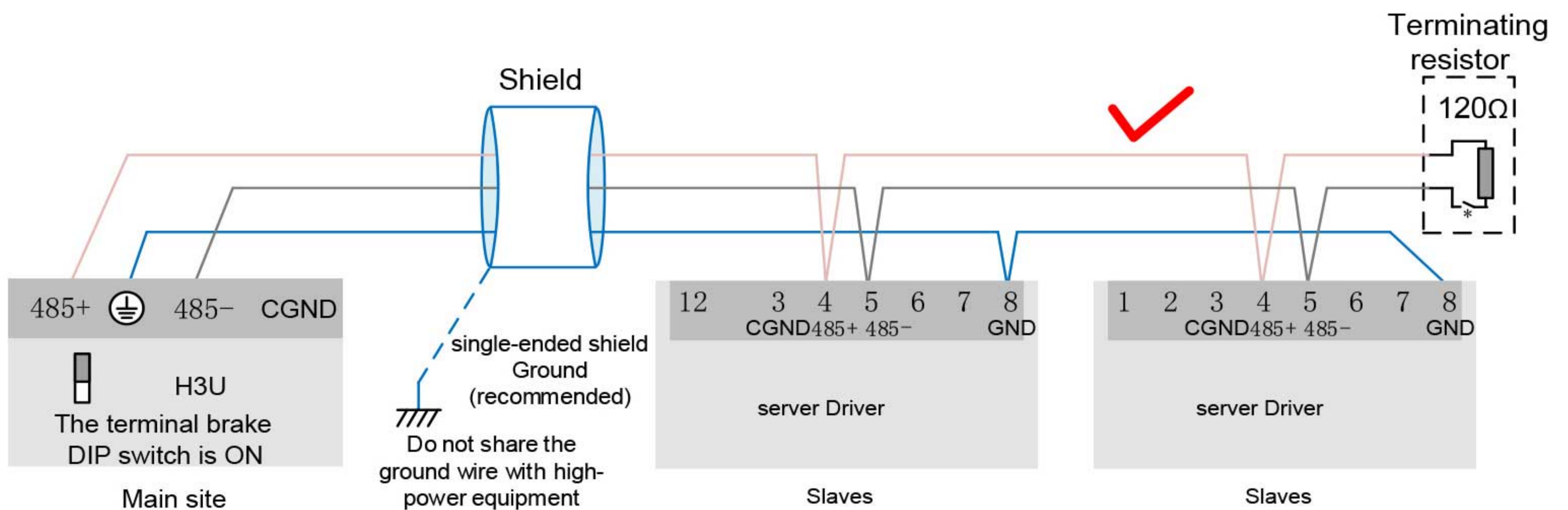

Figure 3-13 correct 485 connect way



notes



- PLC has built-in 485 communication terminal resistance, the corresponding DIP switch must be set to ON;
- It is recommended that the shielding layer be grounded at one end;
- Do not connect the GND terminal of the host device to the CGND terminal of the servo drive, otherwise the machine will be damaged!

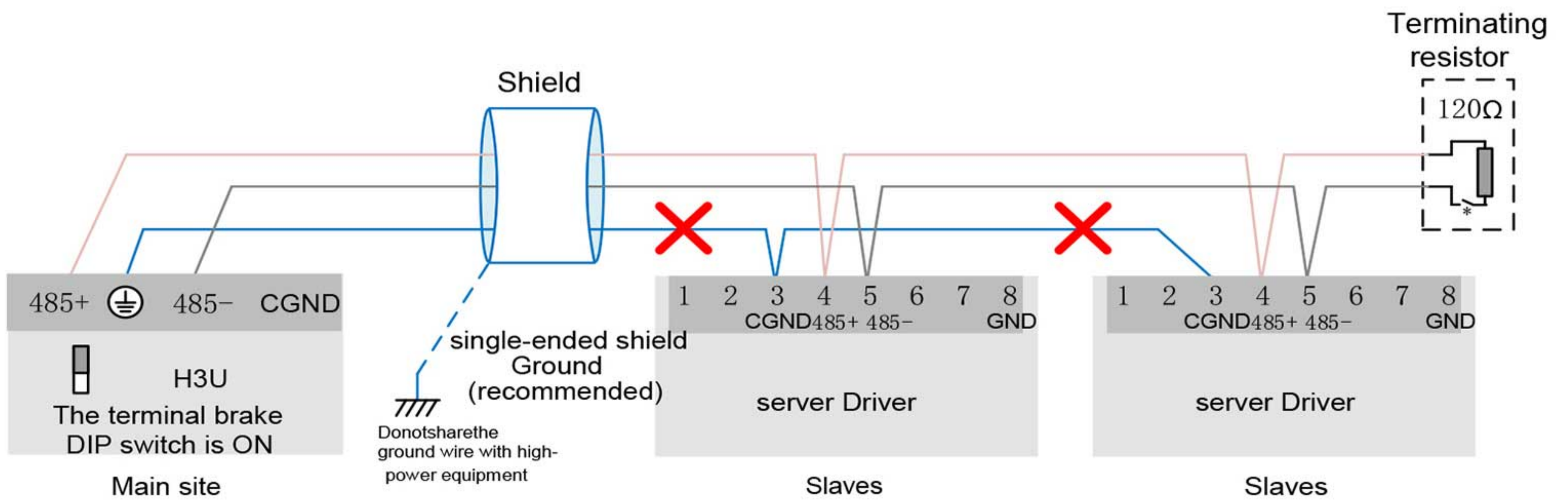

Figure 3-14 wrong 485 connect way

3.5.3 Communication connection with PC (232 communication)

Users can connect the drive and PC through a PC communication cable. It is recommended to use the more commonly used communication interface RS-232. The cable is shown as follows:



Figure 3-15 PC Communication Cable Appearance Example

Sheet 3-11 The pin connection relationship between the driver and the PC communication cable

Servo drive RJ45(A terminal)		PC side DB9 (B terminal)	
Signal No.	Pin No.	Signal No.	Pin No.
RS232-TXD	6	PC-RXD	2
RS232-RXD	7	PC-TXD	3
GND	8	GND	5
PE(Shielded network layer)	Housing	PE(Shielded network layer)	Housing

The corresponding PC terminal DB9 terminal is defined as follows.

Pin No.	Definition	description	Pin No.
2	PC-RXD	PC receiver	
3	PC-TXD	PC sender	
5	GND	ground	
Housing	PE	Shield	

If the host computer is not configured with a serial port and can only be connected to the USB interface, you can use the serial port to USB cable for conversion.

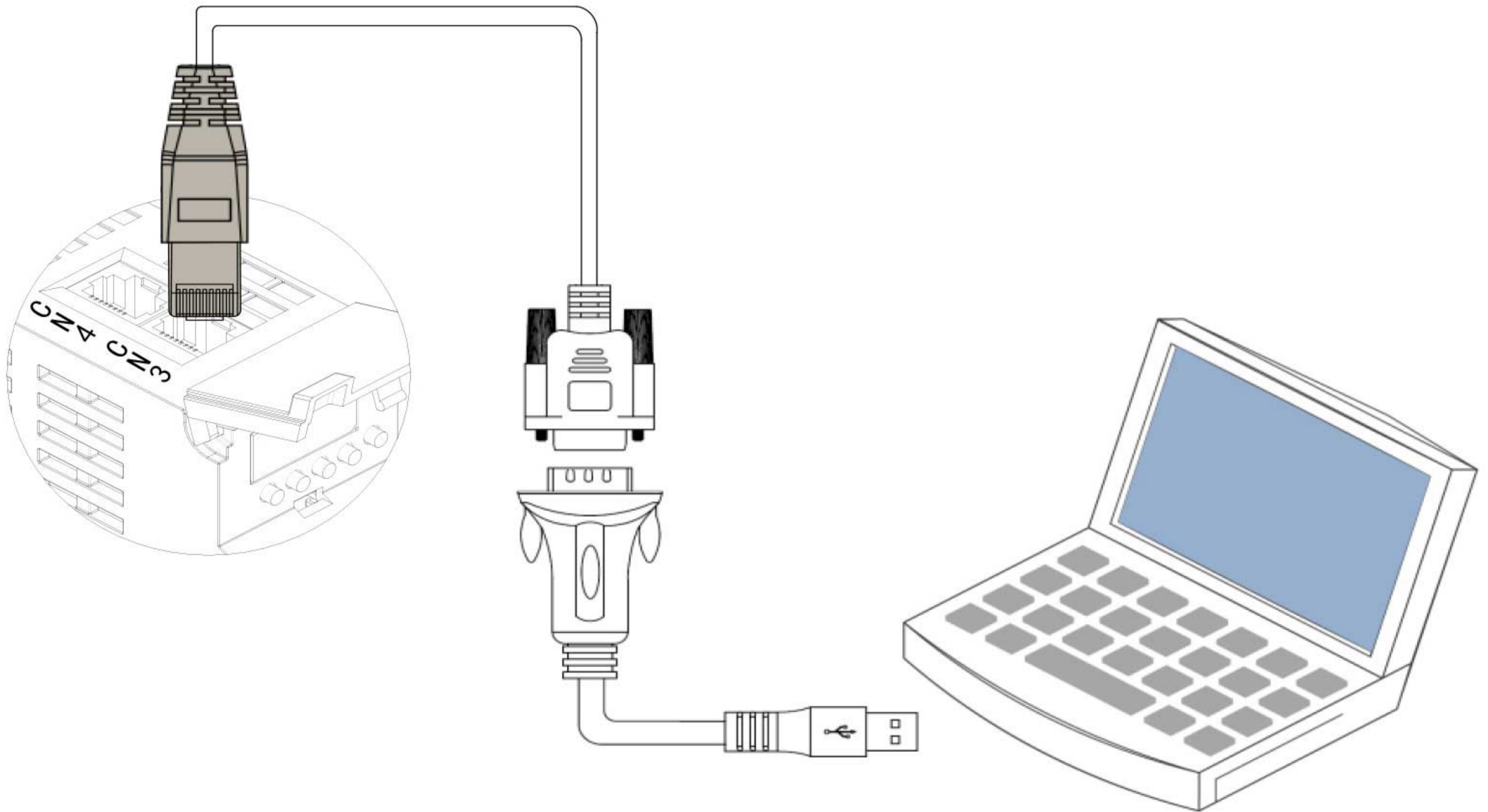

Figure 3-16 USB terminal shows

3.6 Anti-interference countermeasures for electrical wiring

To suppress interference, take the following measures:

The length of the command input cable should be less than 3m, and the encoder cable should be less than 20m. The ground wiring should be as thick as possible. (2.0mm² or more)

- ① It is recommended to use a grounding type D or higher (the grounding resistance value is 100Ω or less).
- ② It must be grounded at one point.

Please use a noise filter to prevent radio frequency interference. Please install a noise filter on the input side of the power cord when using it in a civil environment or in an environment with strong power interference noise.

In order to prevent malfunction caused by electromagnetic interference, the following treatment methods can be adopted:

- ① Install the host device and noise filter as close to the servo drive as possible.
- ② Install surge suppressors on the coils of relays, screw tubes, and electromagnetic contactors.
- ③ When wiring, please separate the strong current circuit from the weak current circuit, and keep the interval of more than 30cm. Do not put in the same pipe or bundle together.
- ④ Do not share the power supply with electric welding machines, electrical discharge machining equipment, etc.

When there is a high-frequency generator nearby, install a noise filter on the input side of the power cord.

3.6.1 Examples of anti-interference wiring and grounding treatment

The main circuit of this servo driver adopts "high-speed switching element". Depending on the peripheral wiring and grounding of the servo driver, switching noise may affect the normal operation of the system. Therefore, proper grounding methods and wiring treatments must be used, and noise filters must be added when necessary.

1.Examples of anti-interference wiring

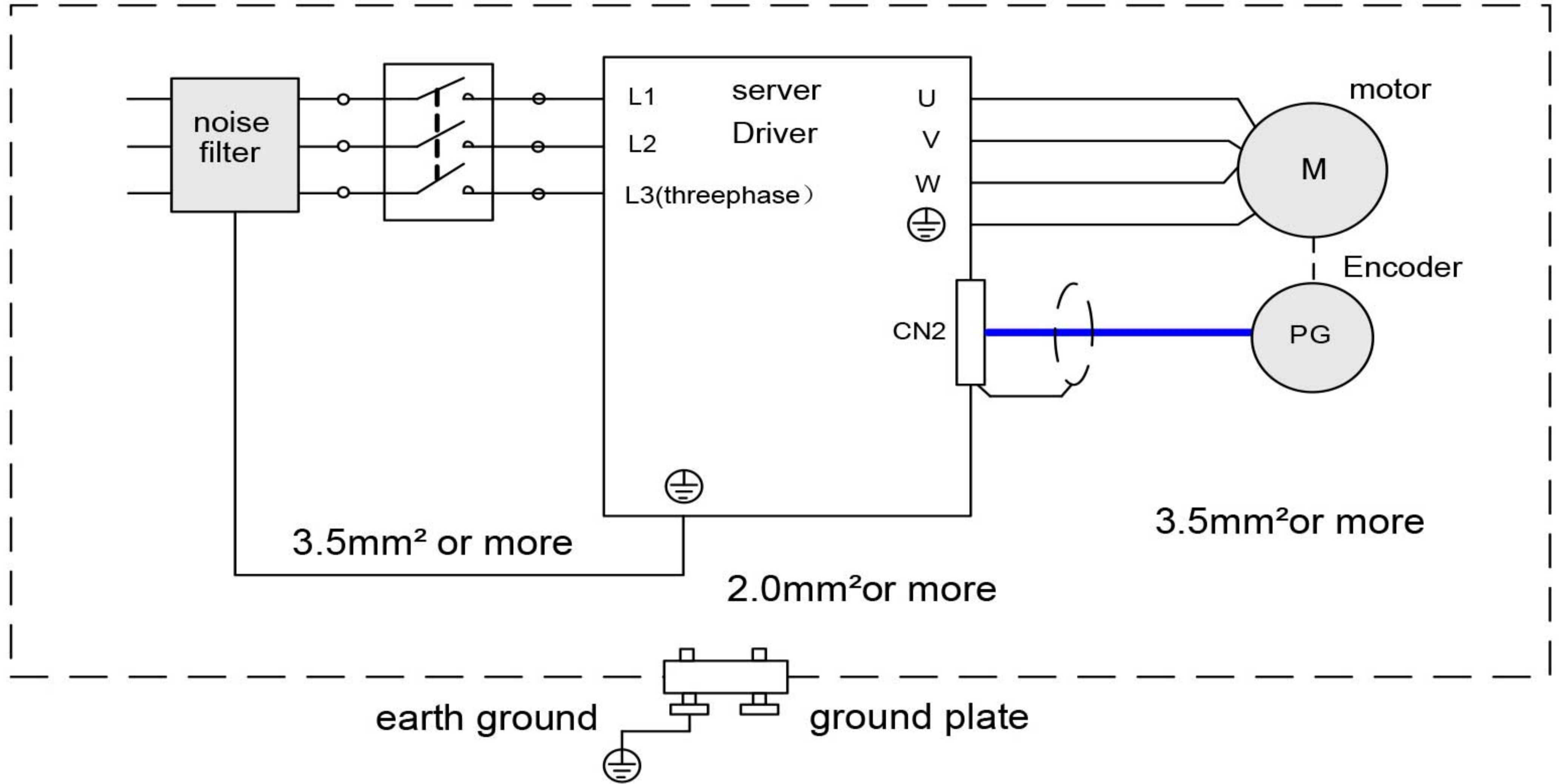

Figure 3-17 Anti-interference wiring example

Notes :

■ Please use a thick wire of 3.5mm² or more for the connection wire of the outer box used for grounding. (Recommended braided copper wire)

■ When using the noise filter, please observe the precautions described in "How to use the noise filter" below.

Ground handling

To avoid possible electromagnetic interference problems, ground as follows.

1) Grounding of the servo motor casing

Please connect the ground terminal of the servo motor and the ground terminal PE of the servo drive together, and ground the PE terminal reliably to reduce potential electromagnetic interference problems.

2) Ground the shielding layer of the power line

Ground the shield or metal conduit in the main circuit of the motor at both ends.

3) Grounding of the servo drive

The ground terminal PE of the servo drive must be grounded reliably, and the fixing screw should be tightened to maintain good contact.

3.6.2 How to use the noise filter

In order to prevent the interference of the power line and weaken the influence of the servo drive on other sensitive equipment, please select a corresponding noise filter at the power input end according to the magnitude of the input current. Also, install noise filters on the power lines of peripheral devices as necessary. When installing and wiring the noise filter, please observe the following precautions so as not to impair the actual use effect of the filter.

1. Please arrange the input and output wiring of the noise filter separately, do not put them in the same pipe or bundle them together.

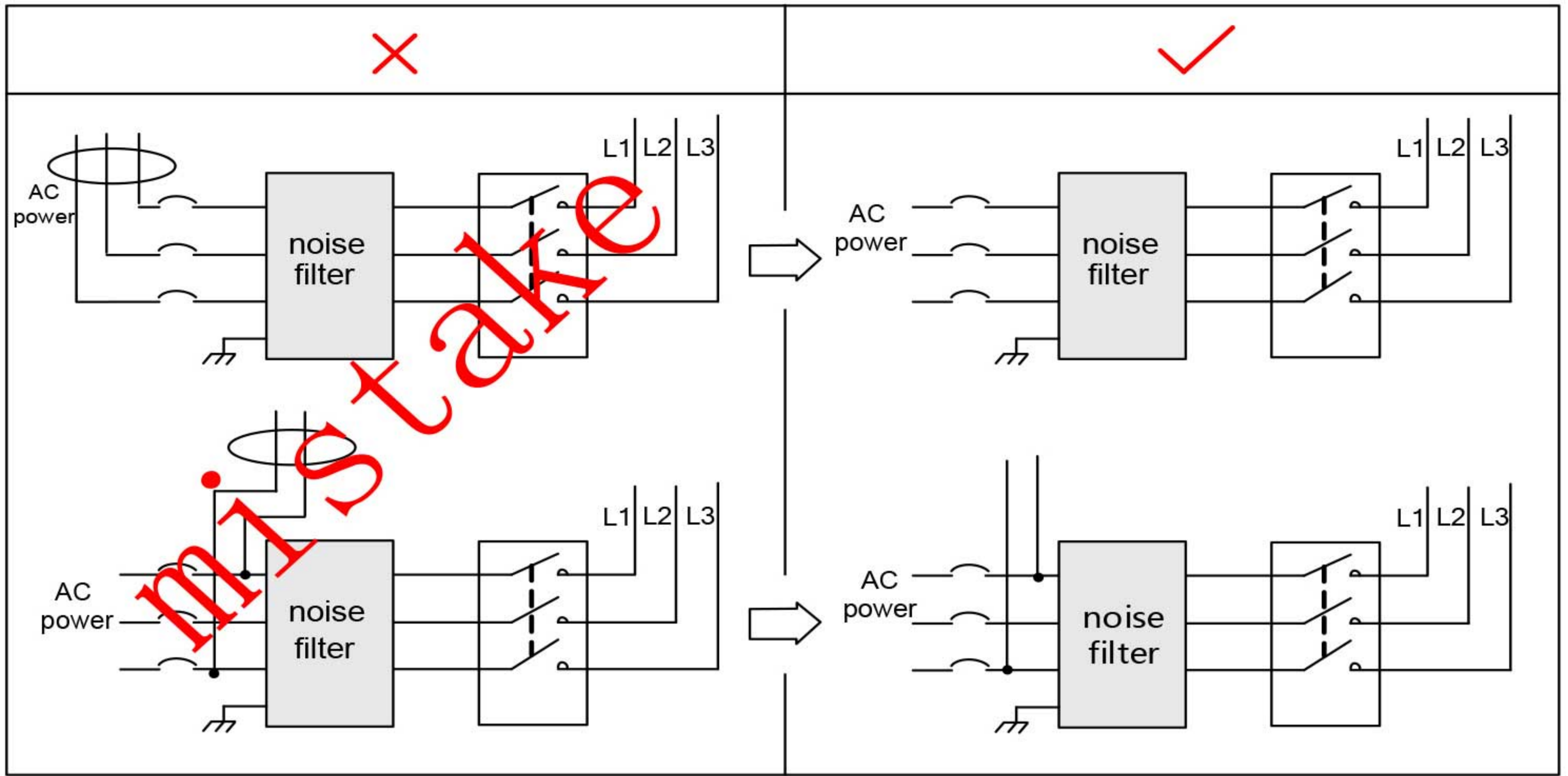

Figure 3-18 Noise filter input and output wiring separation wiring diagram

2.Route the ground wire of the noise filter separately from its output power wire.

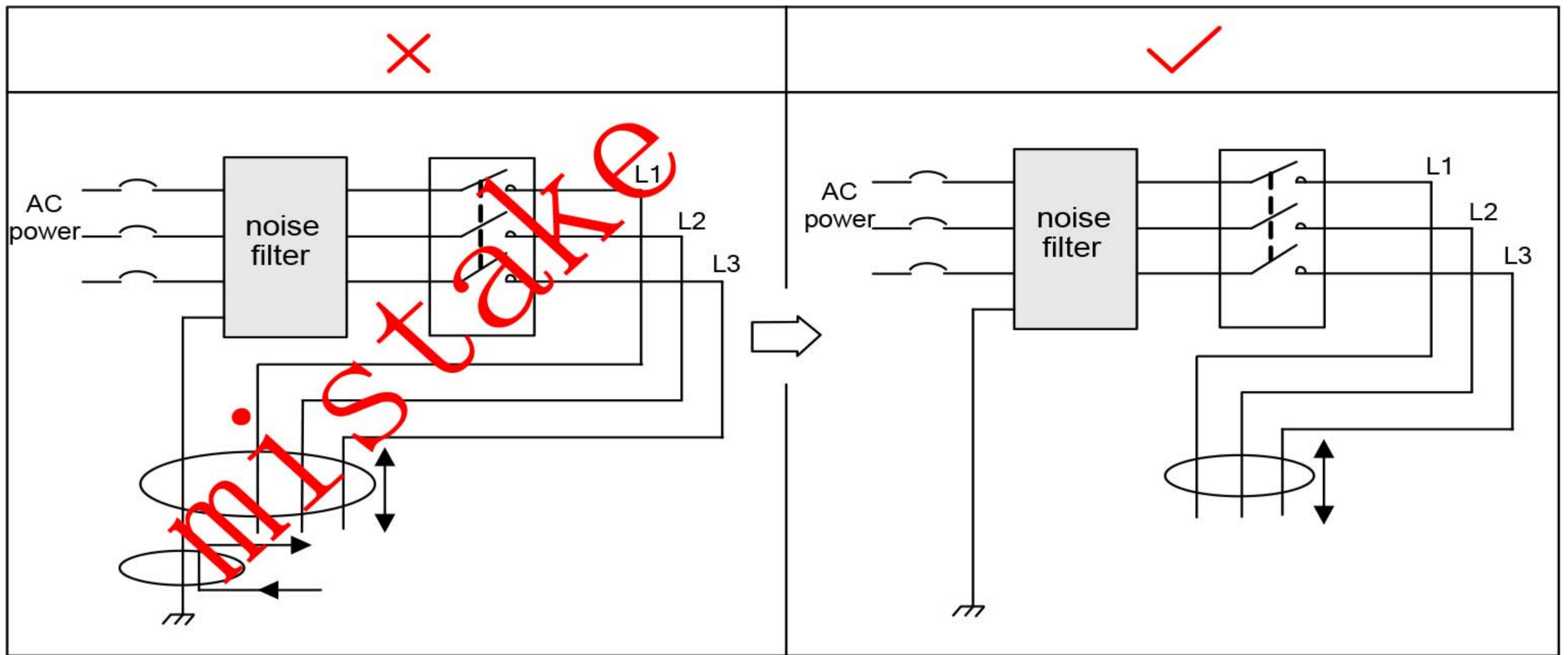

Figure 3-19 Schematic diagram of the separation of the noise filter ground wire and the output wiring

3. The noise filter needs to be grounded separately with a thick wire as short as possible. Do not share a ground wire with other grounding devices.

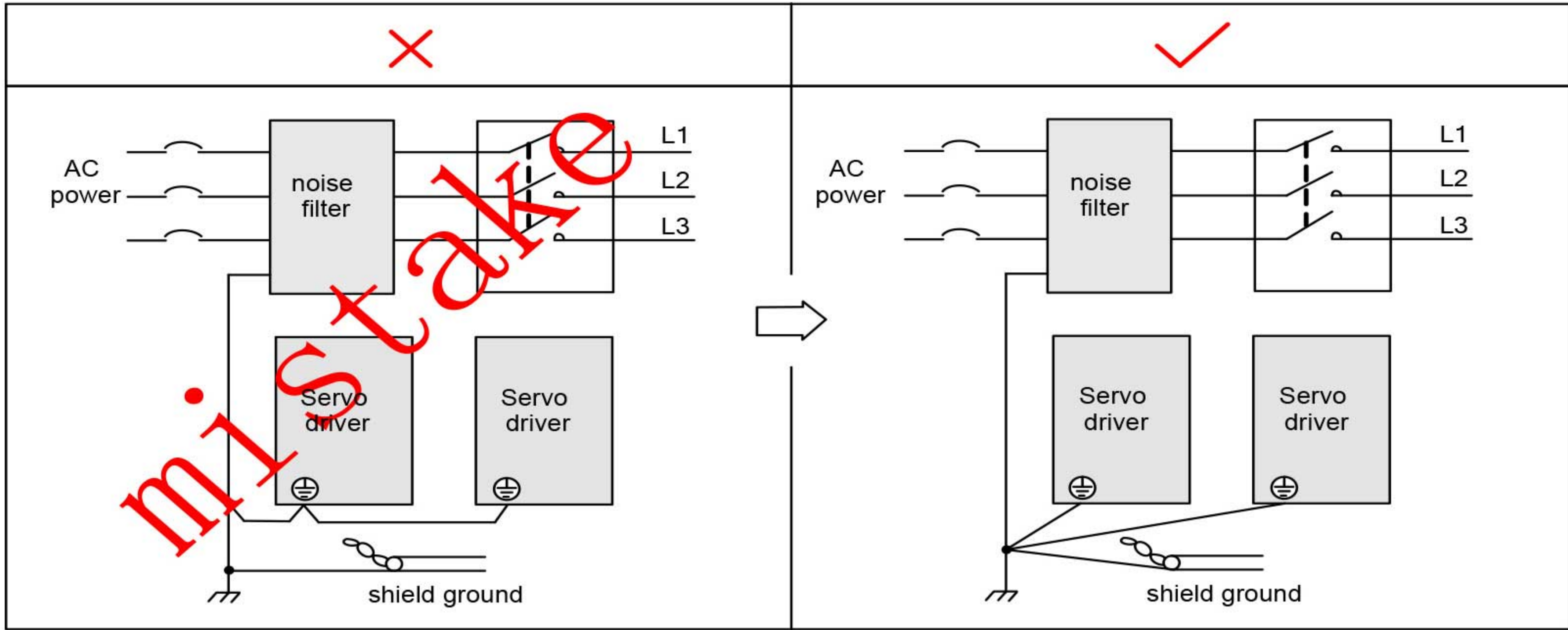

Figure 3-20 Single point grounding diagram

4. The ground wire treatment of the noise filter installed in the control cabinet

When the noise filter and the servo driver are installed in a control cabinet, it is recommended to fix the filter and the servo driver on the same metal plate to ensure that the contact part is conductive and well connected, and the metal plate is grounded.

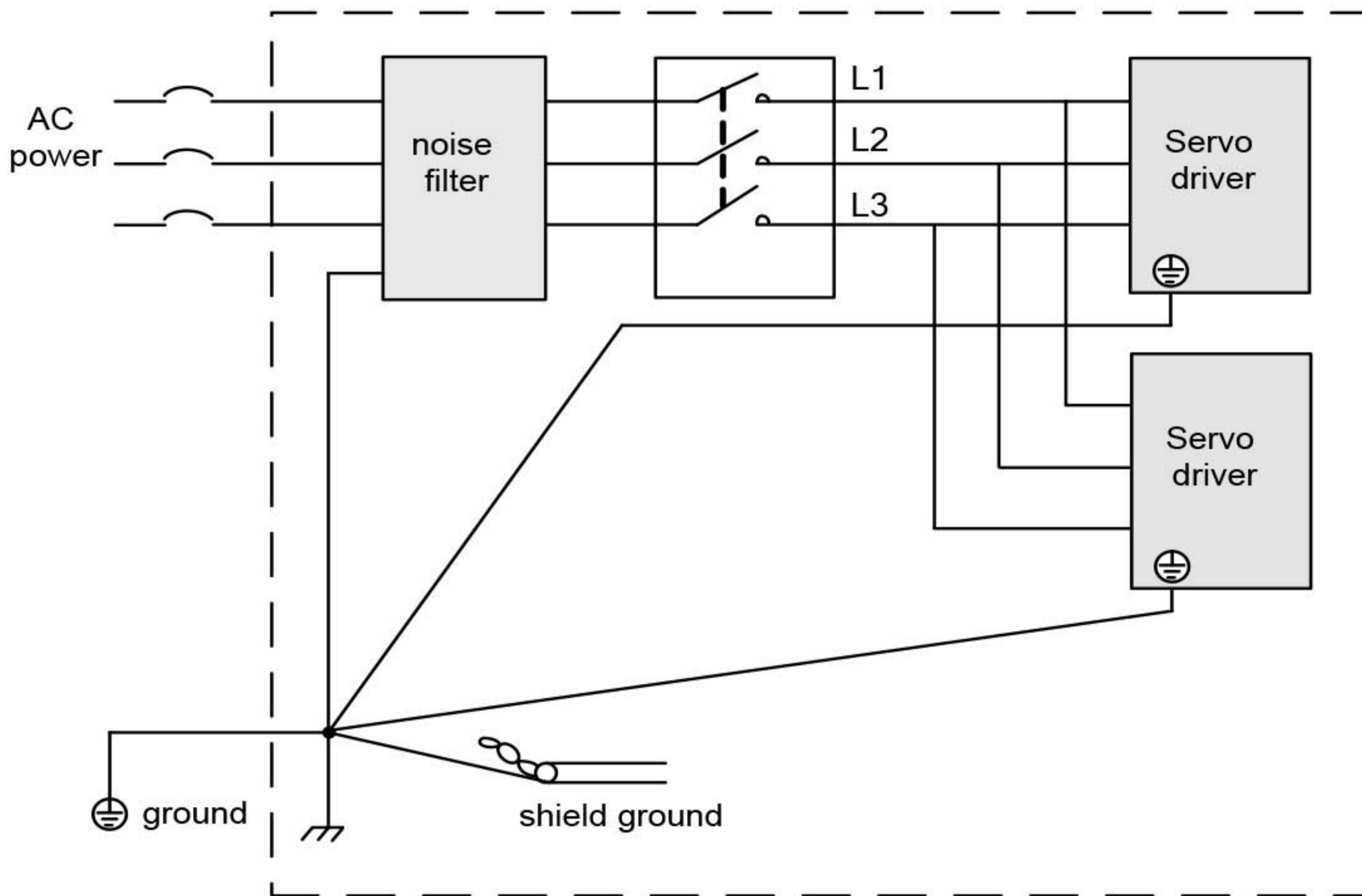

Figure 3-21 Schematic diagram of noise filter ground wire processing

3.7 Precautions for the use of cables

- Do not bend or strain the cable. Since the core wire diameter of the signal cable is only 0.2mm or 0.3mm, it is easy to break, so please be careful when using it.
- When the cable needs to be moved, please use a flexible cable. Ordinary cables are easily damaged after long-term bending. The low-power motor with its own cable cannot be used for cable moving occasions.
- When using a cable protection chain make sure that:
 - The bending radius of the cable is more than 10 times the outer diameter of the cable;
 - Do not fix or bundle the wiring in the cable protection chain, only the two immovable ends of the cable protection chain can be bundled and fixed;
 - Do not twist or twist the cable;
 - The space factor in the cable protection chain is guaranteed to be below 60%;
 - Do not mix cables with too different shapes to prevent the thick wires from crushing the thin wires. If the cables must be mixed and wired, please set a partition device in the middle of the cables.

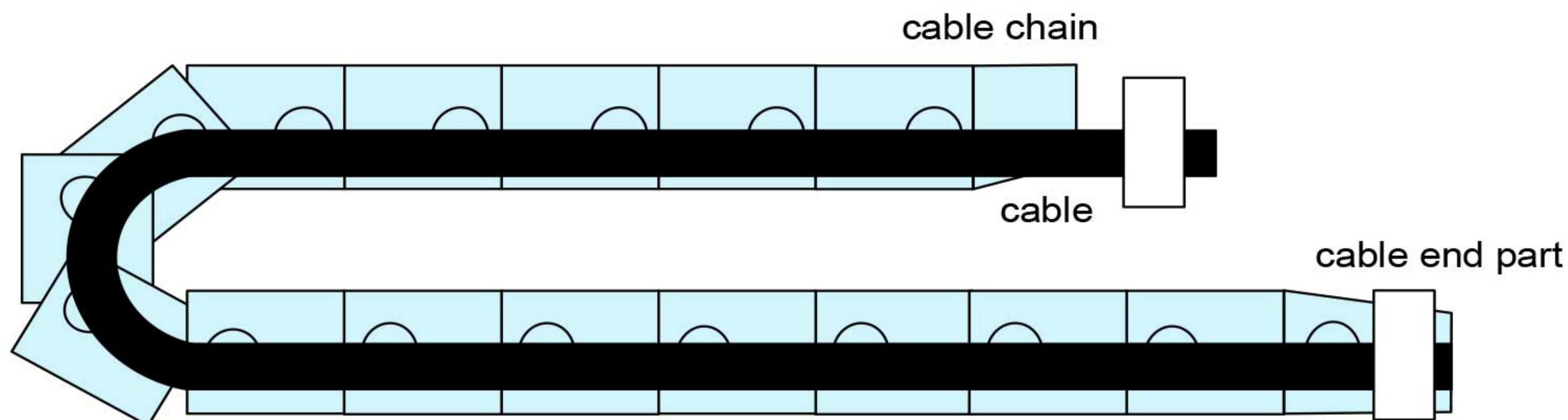

Figure3-22 Schematic diagram of cable protection chain

Chapter 4 Operation and Display

According to the command mode and operation characteristics of the servo drive, it can be divided into three operation modes, namely position control operation mode, speed control operation mode, torque control operation mode, etc. In the position control mode, the displacement of the movement is generally determined by the number of pulses, and the rotational speed is determined by the externally input pulse frequency. Since the position mode can strictly control the speed and position, it is generally used in positioning devices. It is the control mode with the most servo applications, mainly used for manipulators, placement machines, engraving, milling and engraving, CNC machine tools, etc. Speed mode is to control the rotation speed through analog input or digital setting and communication setting, which is mainly applicable to some constant speed occasions. For example, in the application of analog engraving and milling machine, the upper computer adopts position control, and the servo driver adopts speed control mode. Torque control mode is to change the set torque size by changing the setting of analog quantity immediately or changing the corresponding address value through communication. It is mainly used in winding and unwinding devices that have strict requirements on the force of the material, such as some tension control occasions such as winding devices or fiber pulling equipment. The torque setting should be changed at any time according to the change of the winding radius to ensure the force of the material does not change with the change of the winding radius.

4.1 Location Mode Instructions

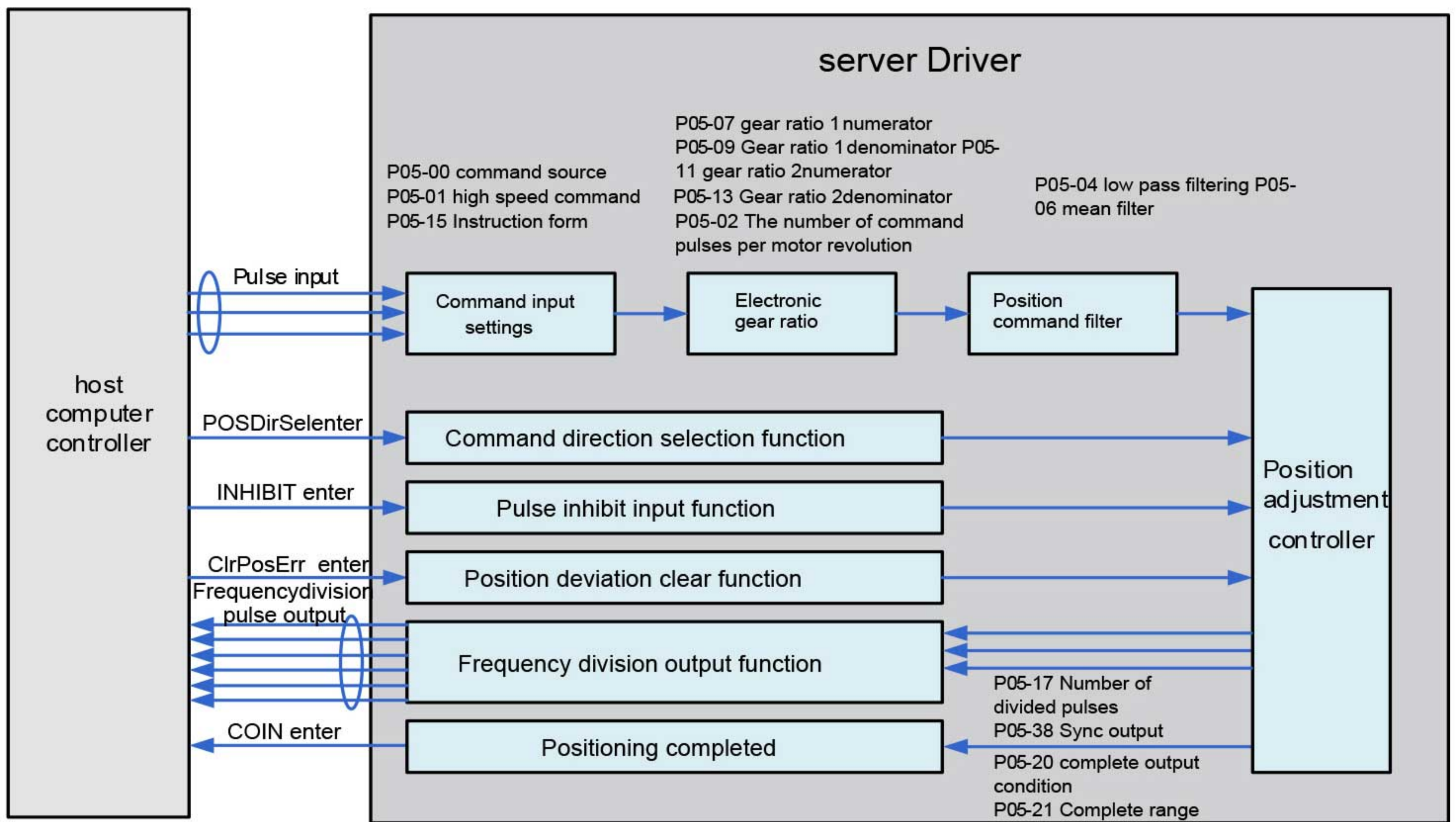
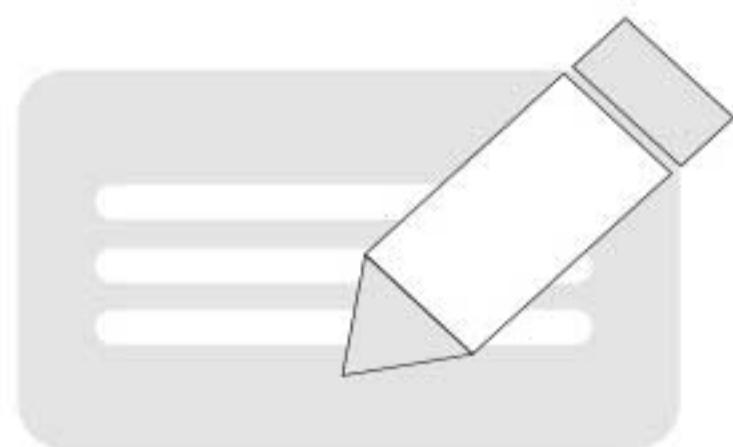

Figure 4-1 Position Control Mode Block Diagram

- The position mode is the common working mode of the servo drive, and its main use steps are as follows:
1. Correctly connect the power supply of the servo main circuit and control circuit, as well as the motor power line and encoder line. After power-on, the servo panel displays "rdy", which means that the servo power supply is correctly wired, and the motor encoder wiring is correct.
 2. Carry out the servo JOG test run by pressing the key to confirm whether the motor can run normally.
 3. Refer to Figure 4-2 for wiring instructions to connect the pulse direction input and pulse command input in the CN1 terminal and necessary DI/DO signals, such as servo enable, positioning completion signal, etc.
 4. Make settings related to the position mode. Set the DI/DO used according to the actual situation, and refer to the P03/P04 group for the function code. In addition, it is necessary to set up functions such as origin return and frequency division output sometimes, see the product comprehensive manual for details.

↙ Indicates twisted pair.



- ◆ The internal +24V power supply voltage range is 20~28V, and the maximum working current is 200mA. If using an external 24V power supply, please connect the external power supply +24V to pin 11 (COM+), and connect the external power supply GND to pin 14 (COM-).
- ◆ DI8 and DI9 are high-speed DIs, please select and use them according to their functions.
- ◆ Please use twisted-pair shielded wire for pulse port wiring. The shielding layer must be connected to PE at both ends, and the GND must be reliably connected to the signal ground of the host computer.
- ◆ DO output power is provided by the user, the power range is 5V~24V. The maximum allowable voltage of the DO port is DC30V, and the maximum allowable current is 50mA.
- ◆ Please choose a twisted pair shielded cable for the frequency division output cable of the encoder. The shielding layer must be connected to PE at both ends, and the GND must be reliably connected to the signal ground of the host computer.

4.1.2 Position control mode related function code setting

Parameter setting in position control mode, including mode selection, command pulse form, electronic gear ratio, DI/DO, etc.

1. Position command input setting

1) Location command source

Setting function code P05-00=0, The position command is derived from the pulse command, and can also be set to other values according to the actual situation.

Function code	Name	Setting range	Unit	Default	Effective way	setting	related model
P05-00	Location command source	0-Pulse command 1-Step amount 2-Multi-segment position command	-	0	Valid	Stop	P

2) Pulse command source

Setting function code P05-01, The specified pulse command comes from the low-speed pulse port or the high-speed pulse port.

Function code	Name	Setting range	Unit	Factory setting	Effective way	setting	related model
P05-01	Pulse command input terminal selection	0-low speed 1-high speed	-	0	power up again	Stop setting	P

3) Position command direction switching

By setting the DI function FunIN.27, the DI can be used to control the direction switching of the position command to meet the situation that the direction needs to be switched.

Code	Name	Function	Description	Notes
FunIN.27	POSDirSel	Position command direction setting	Invalid -the actual position command direction is the same as the set position command direction; Valid -The actual position command direction is opposite to the set position command direction.	The logic selection of the corresponding terminal is recommended to be set to: level valid.



4) Pulse command form selection

Set function code P05-15 to select the form of external pulse command, including “ direction + pulse (positive and negative logic)”, “ A-phase + B-phase quadrature pulse”, and “ CW + CCW” .

Function	Name	Setting range	Unit	Default	Valid setting	Set way	Relative way
P05-15	Pulse command form	0-pulse+direction, positive logic 1 -pulse + direction, negative logic 3-Aphase + B phase quadrature pulse, 4 times frequency 3-CW+CCW	-	0	Power on again	Stop setting	P

The principles of the three pulse command forms are shown in the table below.

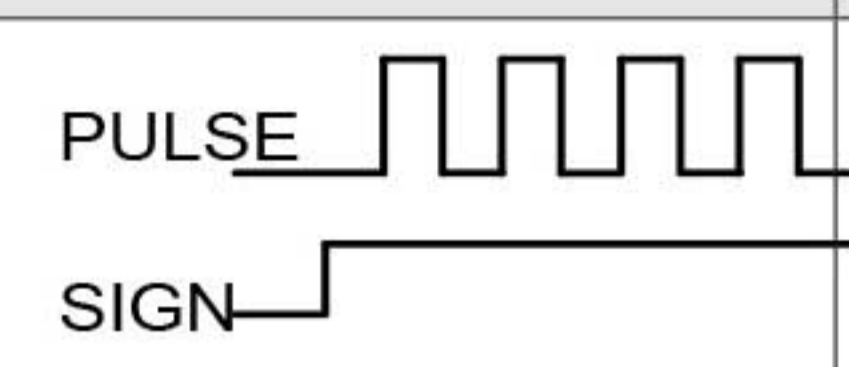
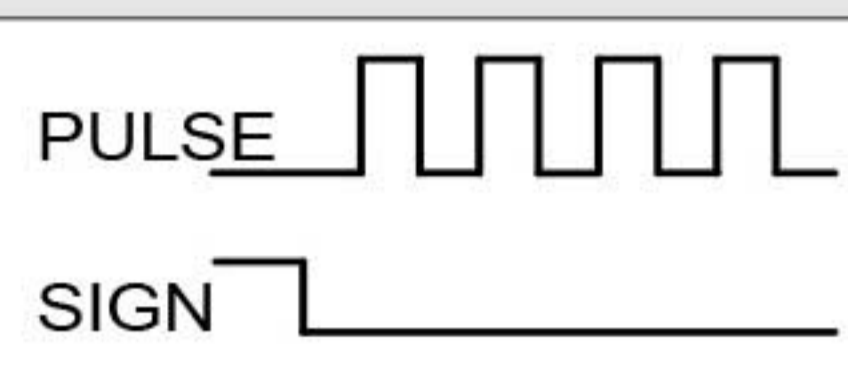
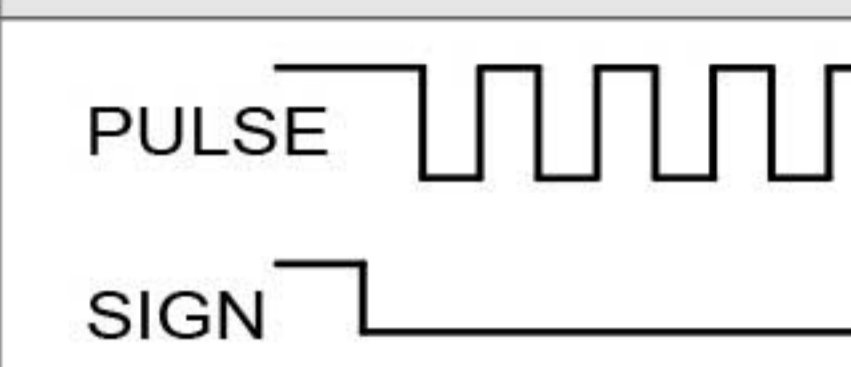
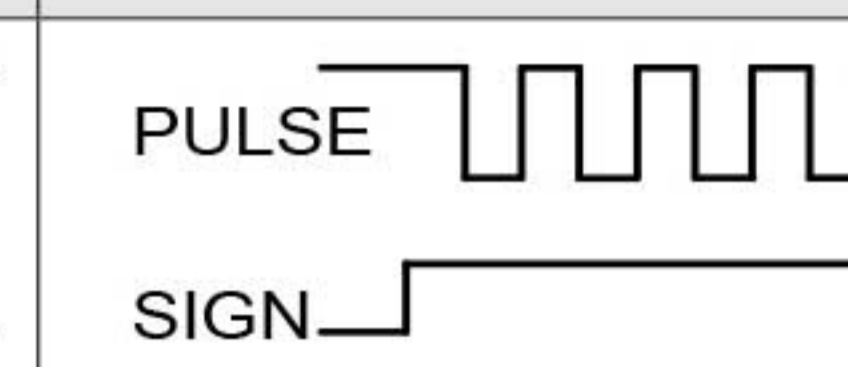
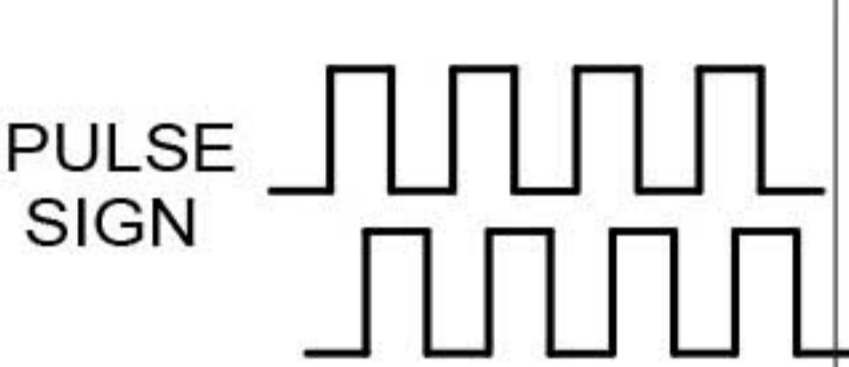
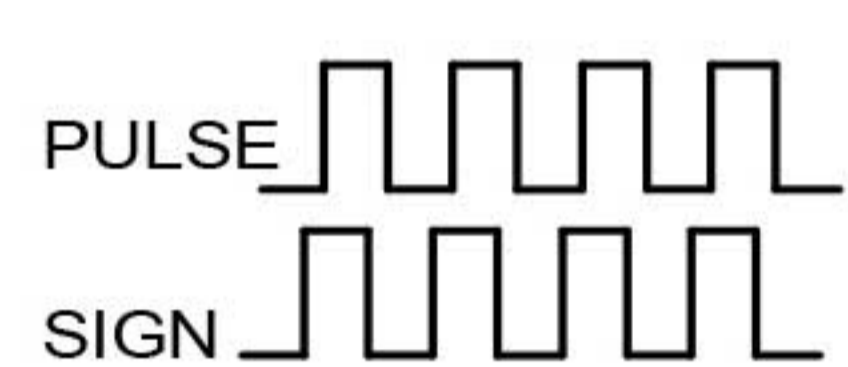
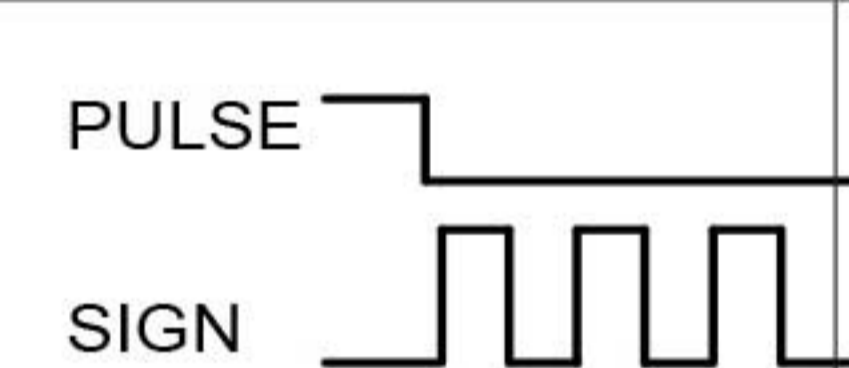
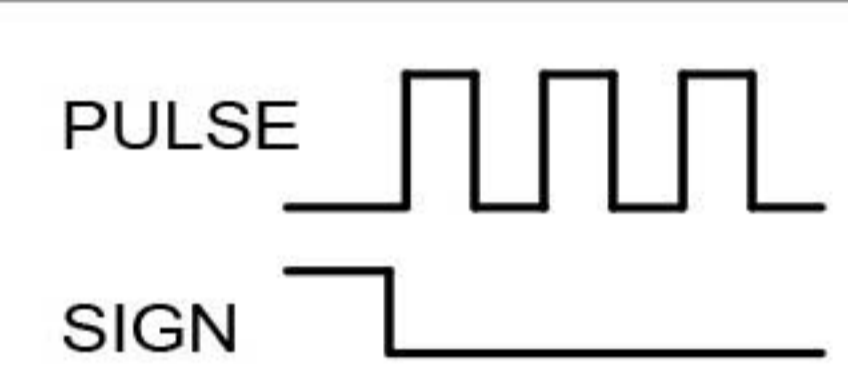
Sheet 4-1 Principle of pulse command form

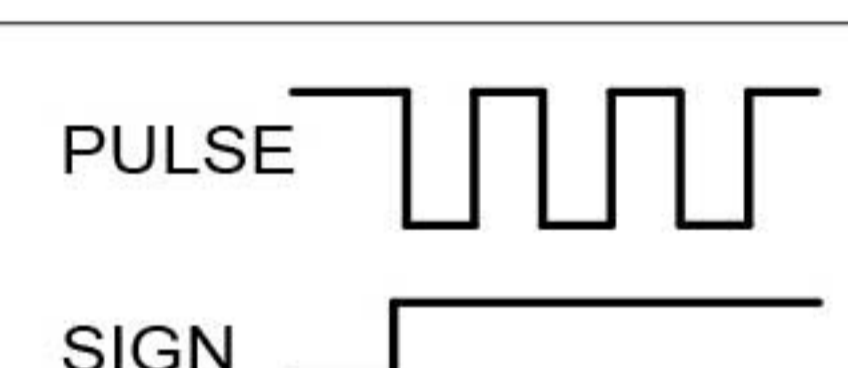
pulse command form	positive logic		negative logic	
	Forward	Reverse	Forward	Reverse
direction + pulse				
quadrature pulse (Aphase + B phase multiplied by 4)				
CW+CCW				
				

5) Positioninstruction prohibition function

Disable pulse command input by setting DI function FunIN.13

Code	Name	Function name	Description	Note
FunIN.13	INHIBIT	Position command prohibited	<ul style="list-style-type: none"> Invalid -in position control mode, the servo drive can respond to the position command; Valid -in position control mode, the servo drive does not respond to any internal and external position commands. 	The original is the pulse inhibit function. It is now upgraded to position command prohibition, including internal and external position commands. The logic selection of the corresponding terminal must be set to: level valid.

2.Electronic gear ratio setting

Set the electronic gear ratio according to the actual situation of the machine and the host computer.

Code	Name	Setting range	Unit	Default	Effective way	Setting way	Related Patterns
P05-07	Electronic gear ratio 1(molecular)	1~1073741824	1	1048576	Effective immediately	Run settings	P
P05-09	Electronic gear ratio 1(denominator)	1~1073741824	1	10000	Effective immediately	Run settings	P
P05-11	Electronic gear ratio 2(molecular)	1~1073741824	1	1048576	Effective immediately	Run settings	P
P05-13	Electronic gear ratio 2(denominator)	1~1073741824	1	10000	Effective immediately	Run settings	P

The working principle of the electronic gear ratio is shown in the following figure:

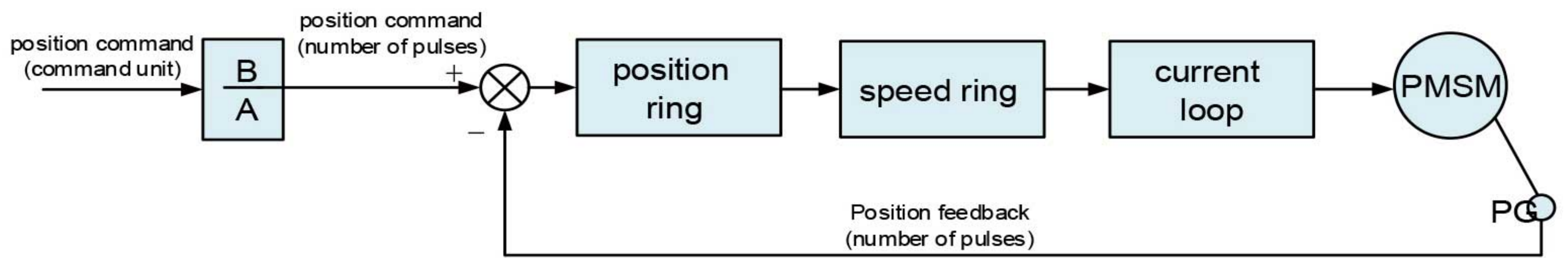

Figure 4-3 Electronic gear ratio principle

When P05-02=0, the motor and the load are connected through a reduction gear. Assuming that the reduction ratio between the motor shaft and the mechanical side of the load is n/m (the motor shaft rotates m turns, and the load shaft rotates n turns), the calculation formula of the electronic gear ratio as follows:

$$\text{Electronic gear ratio } \frac{B}{A} = \frac{P05-07}{P05-09} = \frac{\text{Encoder resolution}}{\text{displacement of axis of rotation}} \times \frac{m}{n}$$

This servo drive supports up to 2 sets of electronic gear ratios, and the gear ratio switching function (FunIN.24) can be used to complete the gear ratio selection.

when P05-02 ≠ 0 :

$$\text{Electronic gear ratio } \frac{B}{A} = \frac{\text{Encoder resolution}}{P05-02}$$

Code	Name	Setting range	Unit	Default	Effective way	Setting way	Patterns
P05-02	The number of position commands per motor revolution	0 ~ 1048576	P/r	0	Power again	Stop setting	P

At this time, the gear ratio has nothing to do with P05-07, P05-09, P05-11, and P05-13, and the gear ratio switching function is invalid.

3. Position command filter setting

Position command filtering is to filter the position command (encoder unit) after frequency or multiplication of the electronic gear ratio. Including first-order low-pass filtering and average filtering.

Consider adding position command filtering in the following situations:

The position command output by the host computer is not processed for acceleration/deceleration;

Low frequency of pulse command;

When the electronic gear ratio is 10 times or more.

The parameters related to the position command smoothing function are set as follows.

Code	Name	Setting range	Unit	Default	Effective way	Setting way	Patterns
P05-04	first-order low-pass filter time constant	0.0 ~ 6553.5	ms	0.0	Effective immediately	Stop setting	P

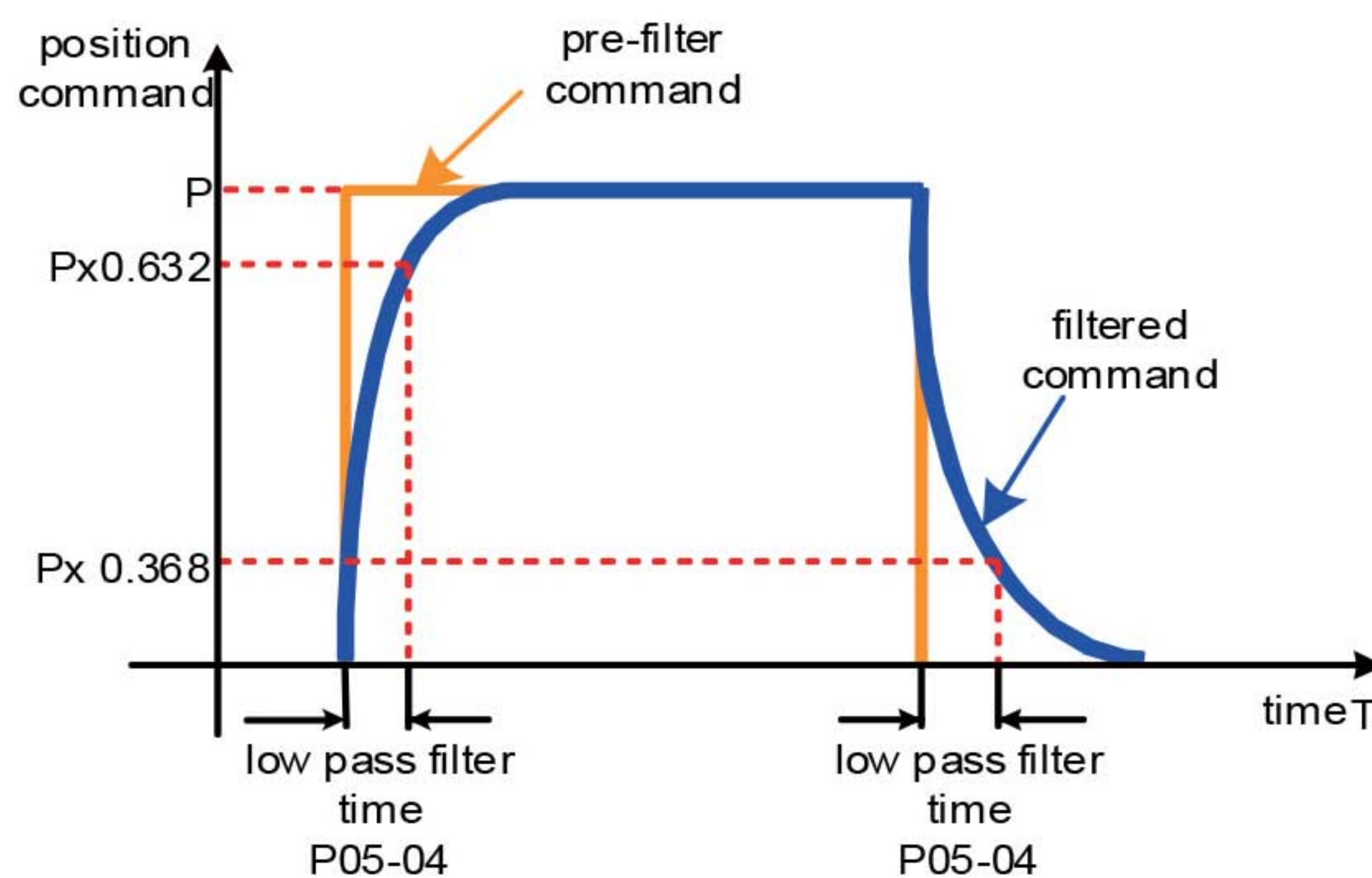
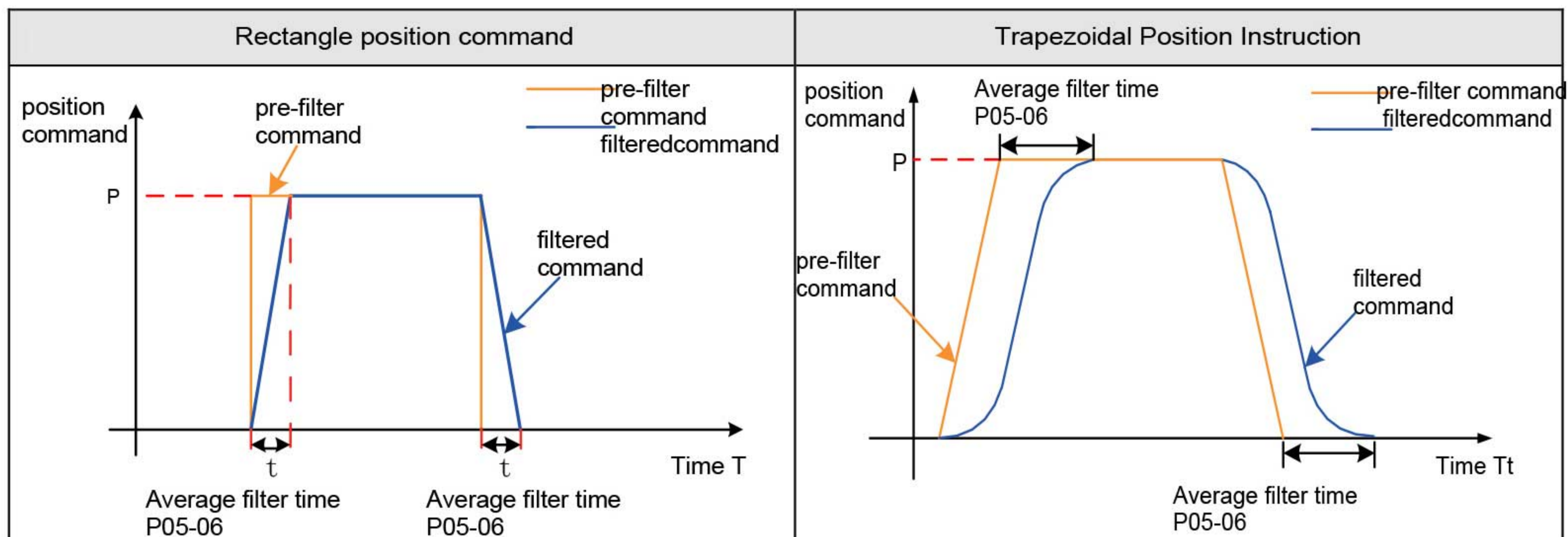

Figure 4-4 Example of a first-order filter

Code	Name	Setting range	Unit	Default	Effective way	Setting way	Related Patterns
P05-06	Average filter time constant	0.0~128.0	ms	0.0	Effective immediately	Stop setting	P

Notes: ■ P05-06=0, mean filter invalid.

Sheet 4-2 Comparison of filtering effect of average filter on two different position commands



4. Position deviation clearing function

By setting the DI function FunIN.35, DI can be used to control whether to clear the position deviation.

Code	Name	Function	Description	Notes
FunIN.35	ClrPosErr	Clear position deviation (edge valid function)	<ul style="list-style-type: none"> ◆ Valid -position deviation is cleared; ◆ Invalid -position deviation is not zero 	The logic selection of the corresponding terminal is recommended to be set to: edge valid. It is recommended to configure this DI function on the DI8 or DI9 terminal.

5. Frequency division output function





The source of servo pulse output is selected by P05-38, and the pulse command synchronous output function is generally used in synchronous control occasions.

Code	Name	Setting range	Unit	Default	Effective way	Setting way	Related Patterns
P05-38	Servo pulse output source selection	0 - encoder frequency division output 1-Pulse command synchronous output 2-divide and sync output disabled	-	0	Power on	Stop	P

By setting P05-17, the servo drive divides the number of pulses fed back by the encoder according to the set value and then outputs it through the frequency-divided output port. The set value of P05-17 corresponds to the number of pulses output by PAO/PBO per revolution (before 4 frequency multiplication).

Code	Name	Setting range	Unit	Default	Effective way	Setting way	Related Patterns
P05-17	Encoder frequency division pulse number	35~32767	P/r	2500	Power on	Stop	-

Sheet 4-3 Output phase shape

Forward rotation (A phase leads B phase by 90°)	When reversed (B phase leads A phase by 90°)
PAO  PBO 	PAO  PBO 

The output pulse feedback phase shape can be adjusted through P02-03.

Code	Name	Setting range	Unit	Default	Effective way	Setting way	Related Patterns
P02-03	output pulse phase	0-Take the CCW direction as the forward rotation direction (A leads B) 1-Take the CW direction as the forward rotation direction (inversion mode, A lags B)	-	0	Power on	Stop	PST

4.2 Speed Mode Instructions

4.2.1 Speed Mode Overview

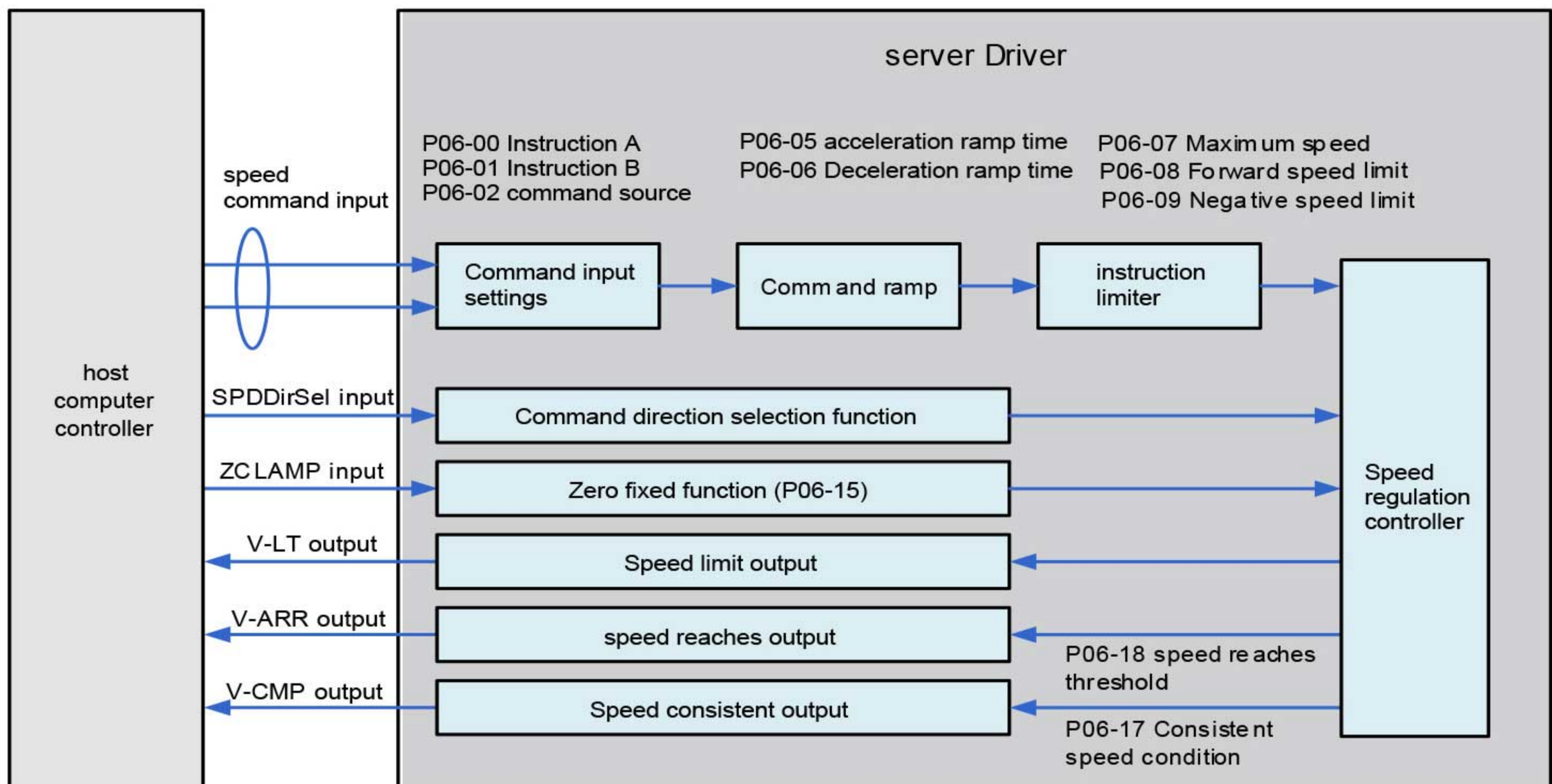

Figure 4-5 Speed Control Mode Block Diagram

The main steps of using the speed control mode are as follows:

- 1) Correctly connect the power supply of the servo main circuit and control circuit, as well as the motor power line and encoder line. After power-on, the servo panel displays "rdy", which means that the servo power supply is correctly wired, and the motor encoder wiring is correct.
- 2) Press the button to perform the servo JOG test run to confirm whether the motor can run normally.
- 3) Connect the necessary DI/DO signals to the CN1 terminal.
- 4) Set the speed mode related settings.
- 5) Enable the servo, first make the motor rotate at low speed, judge whether the rotation direction of the motor is normal, and then adjust the gain, please refer to the general debugging steps in section 4.6.

4.2.2 Speed Control Mode Block Diagram

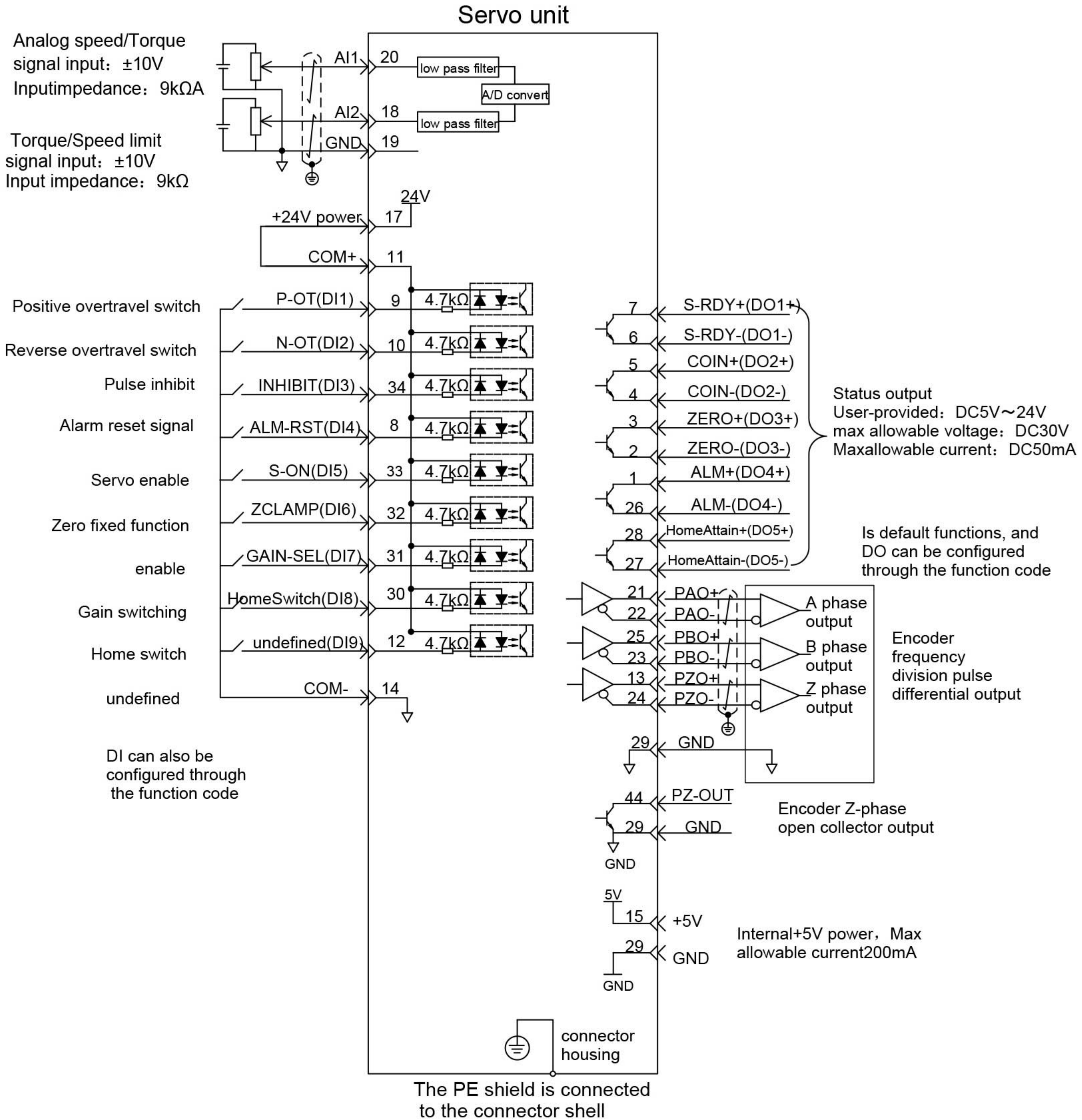
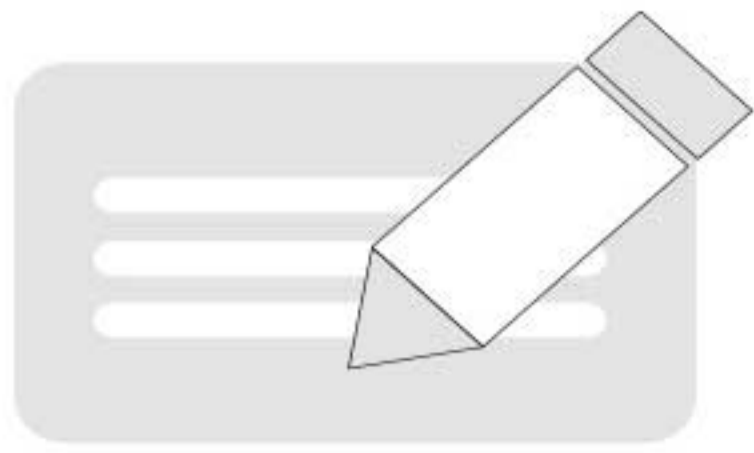

Figure 4-6 Torque Mode Wiring Diagram

↙ Indicates twisted pair.



- ◆ The internal +24V power supply voltage range is 20~28V, and the maximum working current is 200mA. If an external 24V power supply is used, please connect the external power supply +24V to pin 11 (COM+), and connect the external power supply GND to pin 14 (COM-).
- ◆ DI8 and DI9 are high-speed DIs, please select and use them according to their functions.
- ◆ DO output power is provided by the user, the power range is 5V~24V. The maximum allowable voltage of the DO port is DC30V, and the maximum allowable current is 50mA.
- ◆ Please choose a twisted pair shielded cable for the frequency division output cable of the encoder. The shielding layer must be connected to PE at both ends, and the GND must be reliably connected to the signal ground of the host computer.
- ◆ Internal +5V power supply, the maximum allowable current is 200mA.

4.2.3 Speed mode related function code setting

1. Speed command input setting

a) Source of speed command

In speed control mode, the speed command has two sources: sourceA and source B.

Function code	Name	Setting range	Unit	Default	Valid way	Set way	Relative model
P06-00	Main speed command A source	0-digital set (P06-03)	-	0	Effective immediately	Stop set	S
P06-01	Auxiliary speed command B source	0-digital set(P06-03) 1-0 (no effect) 2-0 (no effect) 3-0 (no effect) 4-0 (no effect) 5-Multi-stagespeed command	-	1	Effective immediately	Stop set	S
P06-03	Speed command keyboard setting value	-6000~6000	rpm	200	Effective immediately	Run set	S
P06-04	Jog speed set value	0~6000	rpm	100	Effective immediately	Run set	PST

- Digital setting, namely keyboard setting, refers to storing the set speed value through function code P06-03 and taking it as the speed command.
- This source of the analog speed command refers to converting the externally input analog voltage signal into the command signal for controlling the motor speed.
- You can check the given speed command value through P0B-01.
- Multi-segment speed command means that the user selects 16 groups of speed commands and related control parameters stored in the internal register through external DI or internal designation.
- The jog speed command means that the user sets the jog running function (FunIN.18, FunIN.19) by configuring two external DIs or the control software of the upper computer, and the speed value stored in the function code P06-04 is used as the jog running speed, DI state selects the speed command direction.

a) Speed command direction switching

By setting the function code FunIN.26, DI can be used to control the direction switching of the speed command to meet the needs of the speed command to switch the direction.

Sheet 4-3 Example of analog set speed command operation

Code	Name	Function name	Description	Notes
FunIN.26	SPDDirSel	Speed command direction setting	void -positive direction; Effective -the opposite direction.	The logic selection of the corresponding terminal is recommended to be set to: level valid.

a) Speed command selection

The speed control mode has the following five speed command acquisition methods, which are set by the function code P06-02.

Function code	Name	Setting range	Unit	Default	Valid way	Set way	Relative model
P06-02	Speed command selection	0 -source of main speed commandA 1-Auxiliary speed command B 2-source A+B 3-A/B communication given	-	0	Valid	Stop setting	S

When the speed command selects "A/B switching", that is, when the function code P06-02=3, it is necessary to assign a function definition to the DI terminal. This input terminal determines whether the A command input is valid or the B command input is valid.

Code	Name	Function name	Description	Notes
FunIN.4	CMD-SEL	Main and auxiliary running command switching	Invalid -the current running command isA; Valid -The current run command is B.	The logic selection of the corresponding terminal is recommended to be set to: level valid.

1.Command ramp function setting

The ramp function control function refers to converting the changeable speed command into a relatively smooth constant acceleration and deceleration speed command. by setting the acceleration and deceleration time, to achieve the purpose of controlling the acceleration and deceleration. In the speed control mode, if the given speed command changes too much, it will cause the motor to jump or vibrate violently. If the acceleration and deceleration time of the soft start are increased, the motor can start smoothly and avoid the above situation. Damaged mechanical parts.

☆Related function codes:

Function code	Name	Setting range	Unit	Default	Valid way	Set way	Relative model
P06-05	Speed command acceleration ramp time constant	0~65535	ms	0	Effective immediately	Run set	S
P06-06	Speed command deceleration ramp time constant	0~65535	ms	0	Effective immediately	Run set	S

The ramp function control function converts the step speed command into a relatively smooth constant acceleration and deceleration speed command to achieve smooth speed control (including internal set speed control).

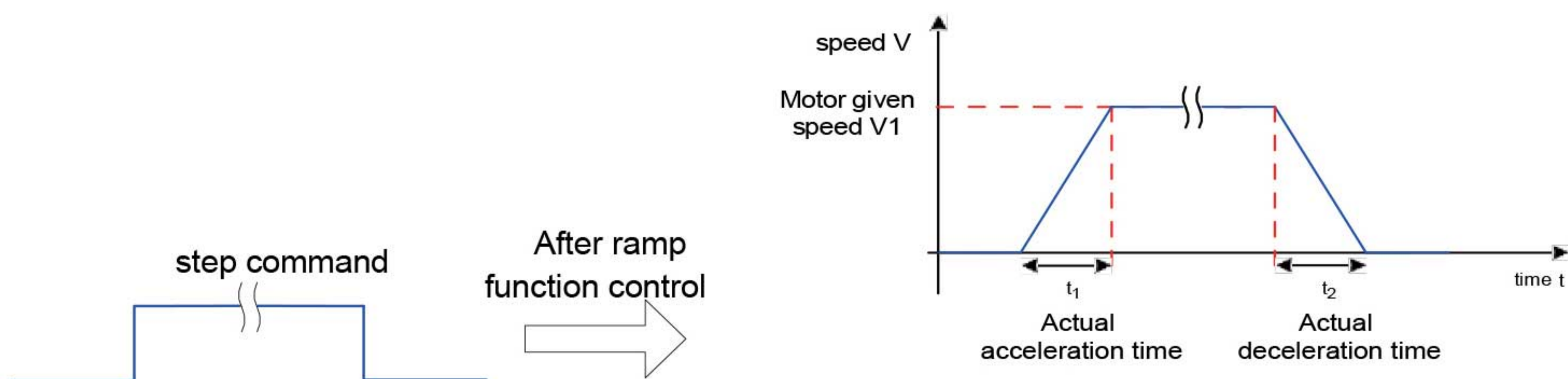

Figure 4-7 Schematic diagram of ramp function

definition P06-05: Time required for speed command to accelerate from zero speed to 1000rpm.

P06-06: The time required for the speed command to decelerate from 1000rpm to zero speed. The actual acceleration and deceleration time calculation formula is as follows:

$$\text{Actual acceleration time} = \frac{\text{speed command}}{1000} \times \text{Speed command acceleration ramp time}$$

$$\text{Actual deceleration time} = \frac{\text{speed command}}{1000} \times \text{Speed command deceleration ramp time}$$

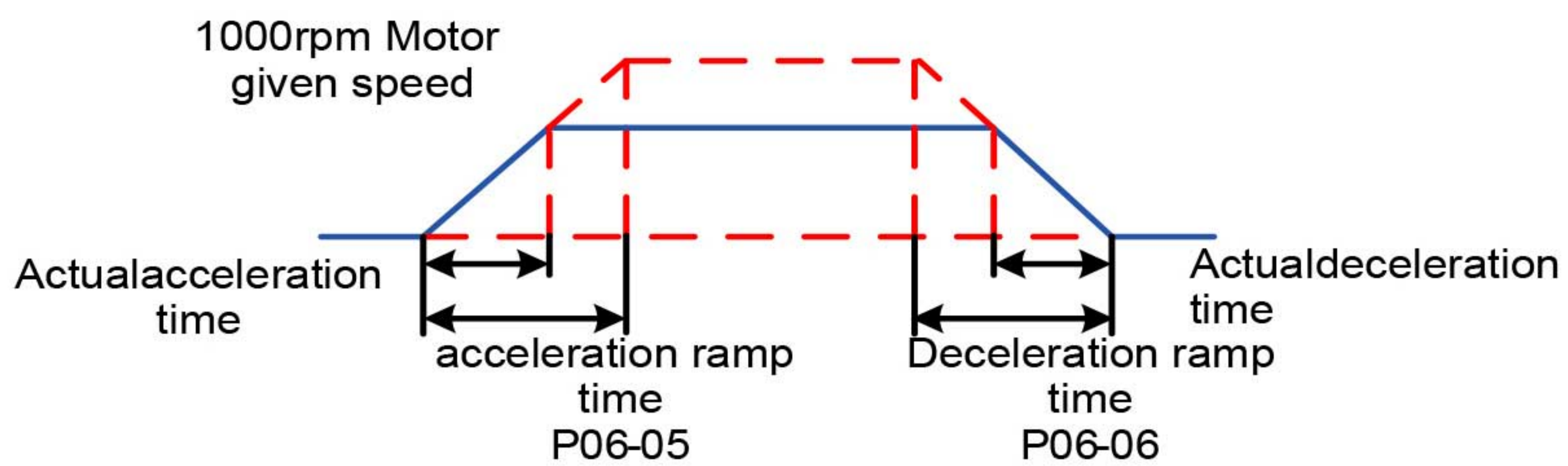

Figure 4-8 Schematic diagram of acceleration and deceleration time

2. Speed command limiter limit setting

In the speed control mode, the servo drive can limit the size of the speed command. Speed command limits include:

- P06-07 sets the range limit of the speed command. The speed command in both positive and negative directions cannot exceed this value, otherwise it will be limited to output at this value.
- P06-08 sets the forward speed limit. If the forward speed command exceeds the set value, the output will be limited to this value.
- P06-09 sets the negative speed limit. If the negative speed command exceeds the set value, the output will be limited to this value.
- P00-15 sets the maximum speed of the motor as the default limit point. When matching different motors, this parameter will change with the motor parameters.

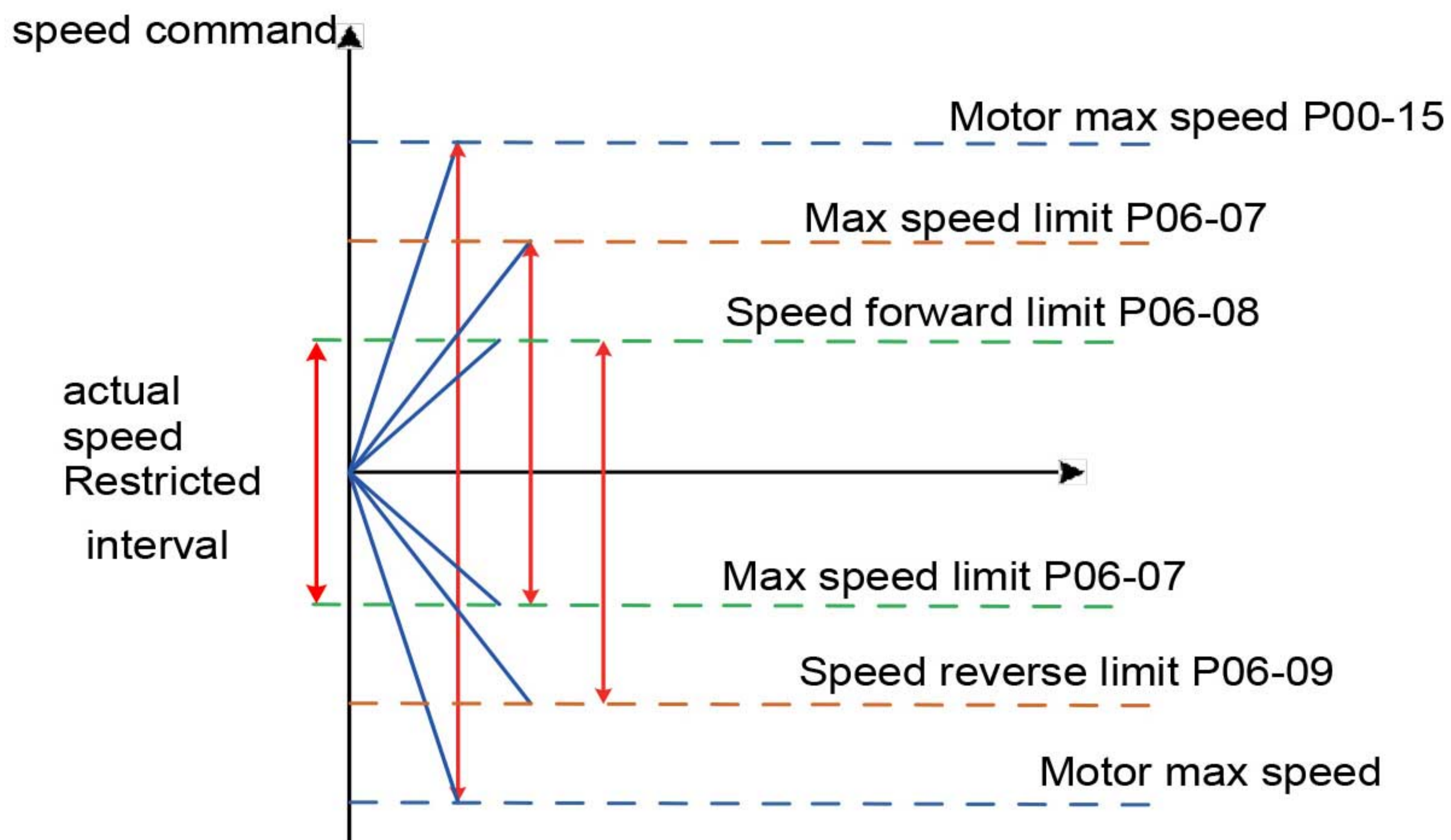

Figure 4-9 Illustration of speed command limit example

The actual motor speed limit range is satisfied:

$$|\text{Amplitude of forward speed command}| \leq \min\{\text{Max. RPM}, \text{P06-07}, \text{P06-08}\}$$

$$|\text{Amplitude of negative speed command}| \leq \min\{\text{Max. RPM}, \text{P06-07}, \text{P06-09}\} \star$$

Related function codes:

Function code	Name	Setting range	Unit	Default	Valid way	Set way	Relative model
P06-07	Maximum speed threshold	0~6000	rpm	6000	Effective immediately	Run settings	S
P06-08	Forward speed threshold	0~6000	rpm	6000	Effective immediately	Run settings	S
P06-09	Reverse speed threshold	0~6000	rpm	6000	Effective immediately	Run settings	S

3.Zero fixed function

In the speed control mode, if the zero-position fixed DI signal FunIN.12 (ZCLAMP) is valid, and the amplitude of the speed command is less than or equal to the speed value set by P06-15, the servo motor enters the control of the zero-position fixed state. Oscillation occurs when the position loop gain can be adjusted. When the amplitude of the speed command is greater than the speed value set by P06-15, the servo motor exits the control of the zero position fixed state.

DI Function selection:

Function code	Name	Setting range	Unit	Default
FunIN.12	ZCLAMP	Zero fixed enable	Valid -enable zero position fix function; Inactive -disables the zero fix function.	The logic selection of the corresponding terminal is recommended to be set to: level valid.

☆ Related function codes:

Function code	Name	Setting range	Unit	Default	Valid way	Set way	Relative model
P06-15	Zero fixed speed threshold	0~6000	rpm	10	Effective immediately	Run settings	S

4.3 Instructions for use of torque mode

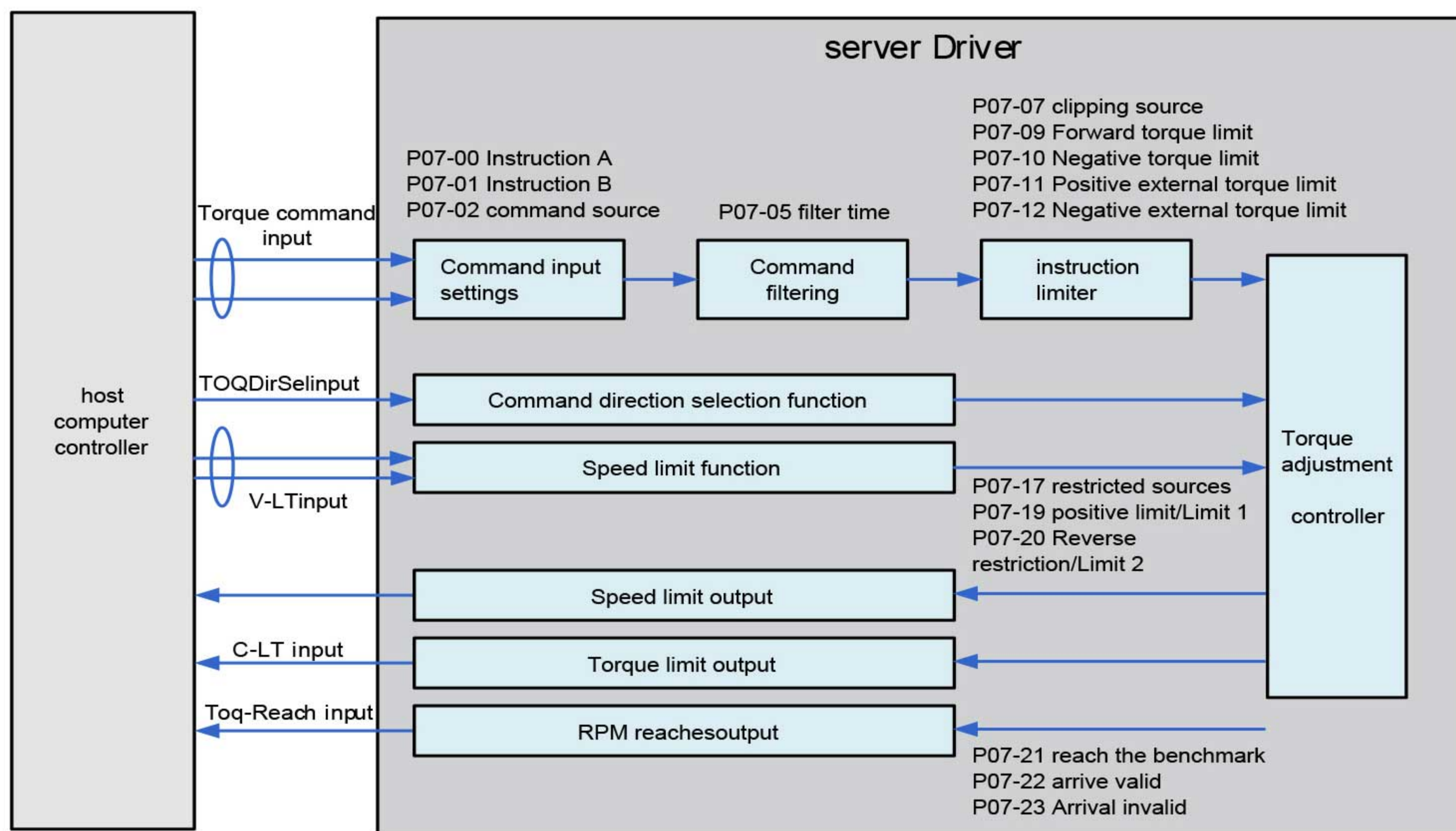

Figure 4-10 Torque Control Mode Block Diagram

The main steps of using torque control mode are as follows:

1)The main steps of using torque control mode are as follows:

Correctly connect the power supply of the servo main circuit and control circuit, as well as the motor power line and encoder line. After power-on, the servo panel displays "rdy", which means that the servo power supply is correctly wired, and the motor encoder wiring is correct.

2) Press the button to perform the servo JOG test run to confirm whether the motor can run normally.

3) Refer to Figure 4-10 for wiring instructions to connect the necessary DI/DO and torque command source, speed limit and other signals in the CN1 terminal.

4) Set related to torque mode.

5) Enable the servo, set a lower speed limit value, and apply a forward orreverse torque command to the servo to confirm whether the motor rotates in the correct direction and whether the speed is correctly limited. If it is normal, it can be used.

4.3.1 Torque Mode Wiring

Servo unit

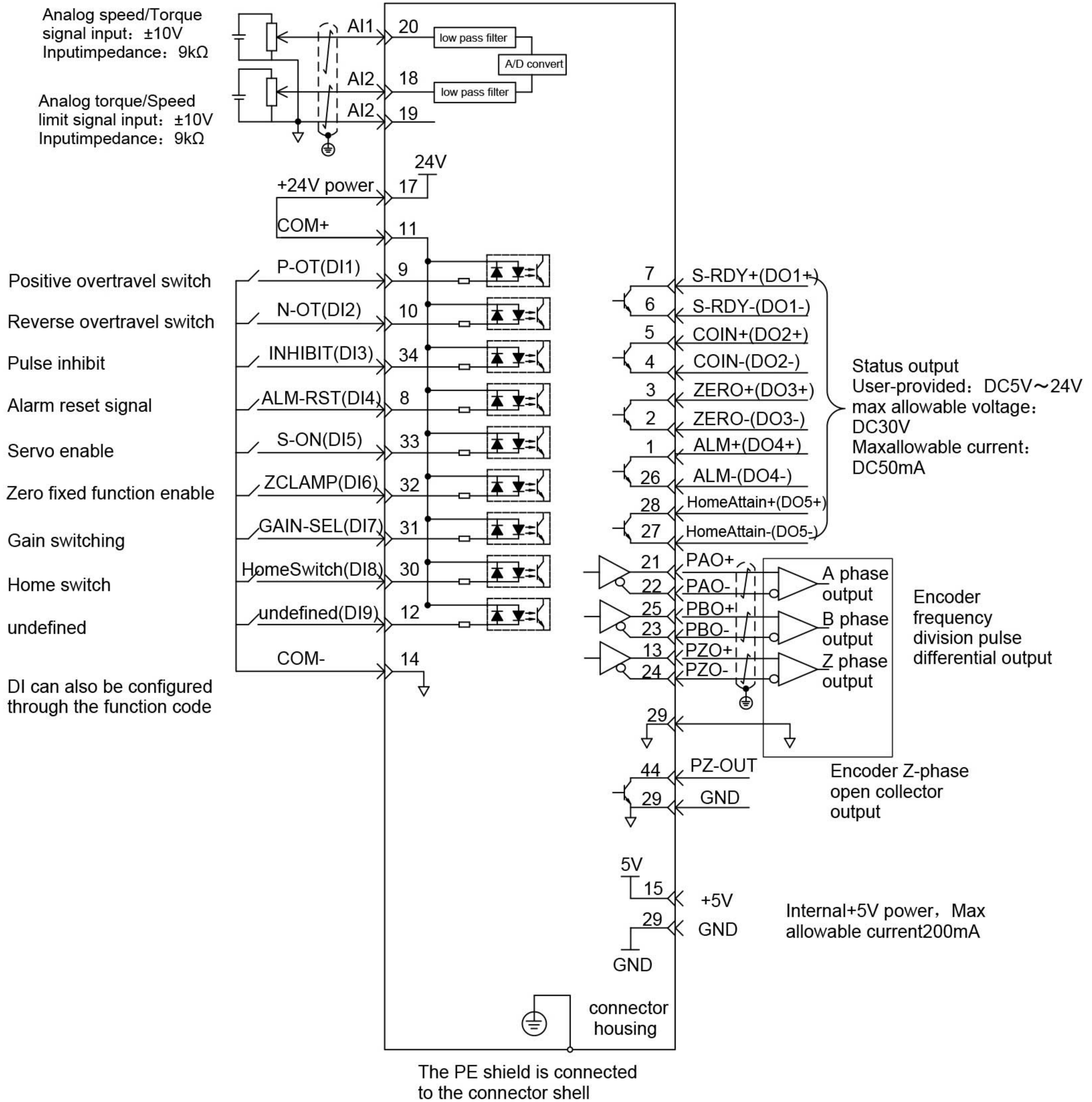
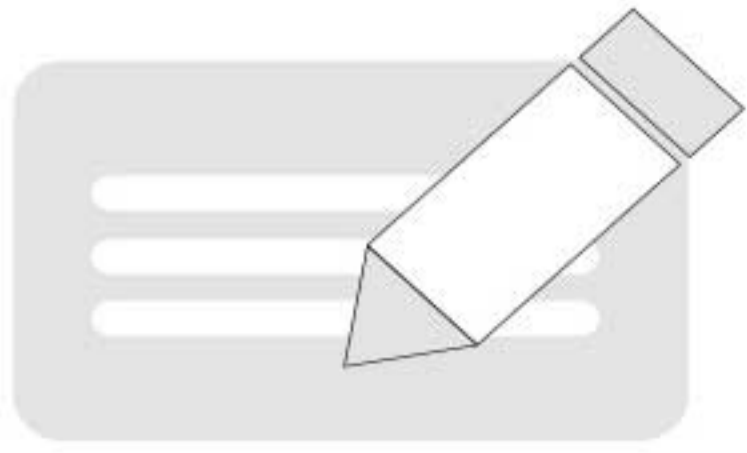

Figure 4-11 Torque Mode Wiring Diagram

↙ Indicates twisted pair.



- ◆ The internal +24V power supply voltage range is 20~28V, and the maximum working current is 200mA. If an external 24V power supply is used, please connect the external power supply +24V to pin 11 (COM+), and connect the external power supply GND to pin 14 (COM-).
- ◆ DI8 and DI9 are high-speed DIs, please select and use them according to their functions.
- ◆ DO output power is provided by the user, the power range is 5V~24V. The maximum allowable voltage of the DO port is DC30V, and the maximum allowable current is 50mA.
- ◆ Please choose a twisted pair shielded cable for the frequency division output cable of the encoder. The shielding layer must be connected to PE at both ends, and the GND must be reliably connected to the signal ground of the host computer.
- ◆ Internal +5V power supply, the maximum allowable current is 200mA.

4.3.2 Torque mode related function code setting

1. Torque command input setting

a) Source of torque command

In torque control mode, there are two sources of torque command: source A and source B. It can be set in two ways:

- Digital setting, namely keyboard setting. Refers to the percentage of the torque value stored in function code P07-03 and the rated torque as the torque command.
- The usage method of the auxiliary torque command B source is the same as the main torque command A source.

☆ Related function codes:

Function code	Name	Setting range	Unit	Default	Valid way	Set way	Relative model
P07-00	Main torque command A source	0-digital setting (P07-03) 1-AI1 2-AI2	-	0	Effective immediately	Stop setting	T
P07-01	Auxiliary torque command B source	0-digital setting (P07-03) 1-AI1 2-AI2	-	1	Effective immediately	Stop setting	T
P07-03	Torque command keyboard setting value	-300.0~300.0	%	0	Effective immediately	Run set	T

b) Torque command selection

Torque control mode has the following five torque command acquisition methods, which are set by function code P07-02.

Function code	Name	Setting range	Unit	Default	Valid way	Set way	Relative model
P07-02	Torque command selection	0-Main torque command A source 1-Auxiliary torque command B source 2-A+B source 3-A/B switching 4-Communication given	-	0	Effective immediately	Stop setting	T

c) Torque command direction switching

By setting the function code FunIN.25, the DI can be used to control the direction switching of the torque command to meet the situation that the direction needs to be switched.

Function code	Name	Setting range	Unit	Default
FunIN.25	TOQDirSel	Torque command direction setting	void -positive direction; Valid -reverse direction.	The logic selection of the corresponding terminal is recommended to be set to: level valid.

When the torque command selects "A/B switching", that is, when the function code P07-02=3, it is necessary to assign a separate function definition to the DI terminal. Use this input terminal to select whether the A command input is valid or the B command input is valid.

Function code	Name	Setting range	Unit	Default
FunIN.4	CMD-SEL	Main and auxiliary running command switching	Invalid -the current running command is A; Valid -The current run command is B.	The logic selection of the corresponding terminal is recommended to be set to: level valid.

The given torque command(the percentage relative to the rated torque of the motor) can be viewed through P0B-02.

1. Torque mode speed limit function

In torque control mode, the speed of the servo motor needs to be limited to protect the machine. During torque control, the servo motor is only controlled by the output torque command and does not control the speed. Therefore, if the set torque command is too large and higher than the load torque on the mechanical side, the motor will continue to accelerate, and over speed may occur. , the speed limit value of the motor needs to be set at this time.

When it exceeds the speed limit range, the speed difference between the speed limit and the speed limit is converted into a certain proportion of torque, and the speed returns to the speed limit range through negative clearing. Therefore, the actual motor speed limit value fluctuates depending on the load conditions. The speed limit value can be given by internal given or analog sampling given. (Same as the speed command during speed control)

Sheet 4-4 speed control model

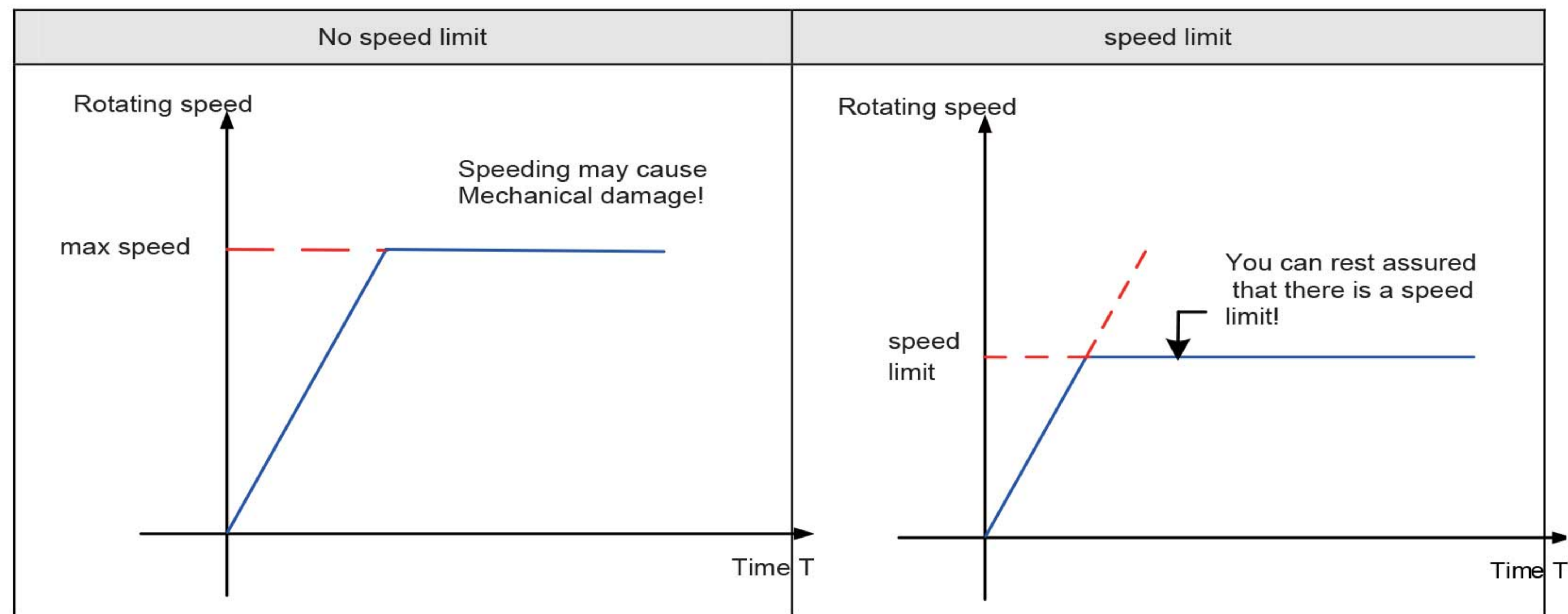

DO function selection: After the motor speed is limited, the output signal is as follows:

Function code	Name	Setting range	Unit	Default
FunOUT.8	V-LT	Speed limit	Acknowledgement signal of speed limitation in torque control: active -the motor speed is limited; Inactive -Motor speed is not limited.	-

Note: ■ V-LT Signals need to be assigned.

Speed limit sources include internal speed limit sources and external speed limit sources. When selecting the internal speed limit source (P07-17=0), directly set P07-19 to limit the forward speed and P07-20 to limit the negative speed. If P07-17=2, in the case of FunIN.36 allocation,

Then select P07-19 or P07-20 as the speed limit through DI.

The speed limit mode is set by the following function codes

Function code	Name	Setting range	Unit	Default	Valid way	Set way	Relative model
P07-17	Speed limit source selection	0 -Internal speed limit (speed limit during torque control) 1-0 (no effect) 2-Select P07-19/P07-20 as internal speed limit through FunIN.36(V-SEL)	-	0	Effective immediately	Run set	T
P07-19	Torque control forward speed limit value/torque control speed limit value 1	0~6000	rpm	3000	Effective immediately	Run set	T
P07-20	Torque control reverse speed limit value/torque control speed limit value 2	0~6000	rpm	3000	Effective immediately	Run set	T

2.Torque command limit setting

In order to protect the mechanical device, the output torque can be limited by setting the function code P07-07. The torque limit can be selected in the following ways:

Function code	Name	Setting range	Unit	Default	Valid way	Set way	Relative model
P07-07	Torque Limit Source	0 -positive and negative internal torque limit (default) 1-Positive and negative external torque limit (Using P-CL, N-CL selection)	-	0	Effective immediately	Stop setting	PST

DI function selection: input forward/reverse external torque limit selection signal P-CL/N-CL.

Function code	Name	Setting range	Unit	Default
FunIN.16	P-CL	Positive external torque limit	According to the selection of P07-07, switch the torque limit source. When P07-07=1: Valid -external torque limit for forward rotation is valid; Invalid -Internal torque limit for forward rotation is valid.	The logic selection of the corresponding terminal is recommended to be set to: level valid
FunIN.17	N-CL	Anti-external torque limit	According to the selection of P07-07, switch the torque limit source. When P07-07=1: Valid -Reverse external torque limit is valid; Invalid -Reverse internal torque limit is valid.	The logic selection of the corresponding terminal is recommended to be set to: level valid.

DO Function selection: output torque limit confirmation signal C-LT.

Function code	Name	Setting range	Unit	Default
FunOUT.7	C-LT	Torque limit signal	Confirmation signal of torque limit: valid -the motor torque is limited; Inactive -Motor torque is not limited.	-

DI/DO related function codes need to be set for function and logic assignment.

- When P07-07=1, the external torque limit of forward and reverse rotation is triggered by external DI reference (P-CL, N-CL), and the torque is limited according to the value set by P07-11 and P07-12.

Function code	Name	Setting range	Unit	Default	Valid way	Set way	Relative model
P07-07	Torque Limit Source	0 -positive and negative internal torque limit 1-Positive and negative external torque limit (Using P-CL, N-CL selection)	-	0	Effective immediately	Stop setting	PST
P07-09	Positive internal torque limit	0.0~400.0 (100% Corresponding to double the rated torque)	%	350.0	Effective immediately	Run setting	PST
P07-10	Negative internal torque limit	0.0~400.0 (100% Corresponding to double the rated torque)	%	350.0	Effective immediately	Run setting	PST

P07-11	Positive external torque limit	0.0~400.0 (100% Corresponding to double the rated torque)	%	350.0	Effective immediately	Run setting	PST
P07-12	Negative external torque limit	0.0~400.0 (100% Corresponding to double the rated torque)	%	350.0	Effective immediately	Run setting	PST

4.4 Instructions for using the absolute value system

4.4.1 Introduction

The absolute encoder not only detects the position of the motor within one rotation, but also counts the number of rotations of the motor. The single-turn resolution is 8388608 (), and it can store 16-bit multi-turn data. The absolute value system composed of absolute value encoder is divided into absolute position linear mode and absolute position rotation mode, which can be used in position, speed and torque control modes. When the drive is powered off, the encoder backs up data through the battery. The drive calculates the absolute position of the machine through the absolute position of the encoder, and there is no need to repeat the operation of returning to the machine origin.

When this series of servo drives match the absolute value encoder, it is necessary to set the motor number P00-00=14130 (our company's 17-bit absolute value encoder), and set P02-01 (absolute value system selection) according to the actual application. FU.731 (encoder battery fault) will occur when the battery is connected for the first time, and it is necessary to set P0D-20=1 to reset the encoder fault, and then perform the origin return operation.

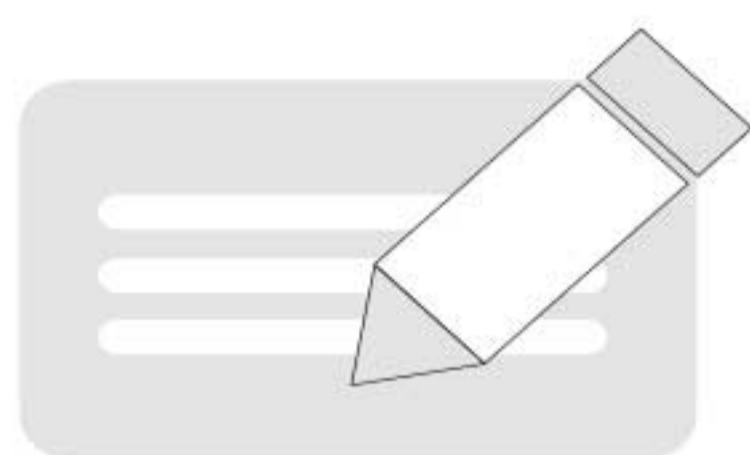

- ◆ When modifying the operation of P02-02 (rotation direction selection) or P0D-20 (absolute encoder reset enable), the absolute position of the encoder will change abruptly, resulting in the change of the mechanical absolute position reference. Therefore, the mechanical origin return operation is required. When using the return-to-origin function inside the drive, the drive will automatically calculate the deviation between the absolute position of the machine and the absolute position of the encoder when the return-to-origin is completed, and store it in the drive EEPROM.

4.4.2 Related function code settings

1. Absolute value system settings

Set P00-00=14130 to select our company's 17-bit absolute encoder motor, and select the absolute position mode through P02-01.

Function code	Name	Setting range	Unit	Default	Valid way	Set way	Relative model
P00-00	Motor code	14130: Tamagawa absolute encoder motor 22□□□: 220V class incremental encoder motor	-	14130	again power ups	Stop set	ALL
P00-08	Absolute encoder type	14100: Multi-turn absolute encoder Other: Single-turn absolute encoder	-	-	again power ups	Stop set	ALL
P02-01	Absolute value system selection	0: Incremental position mode 1: Absolute position linear mode 2: Absolute position rotation mode	-	0	again power ups	Stop set	ALL



- ◆ In absolute position mode, the system automatically detects whether the motor number is an absolute encoder motor. If the setting is incorrect, "FU.122 Product matching fault in absolute position mode" will occur.

2. Absolute position linear mode

Function code	Name	Setting range	Unit	Default	Valid way	Set way	Relative model
P05-46	Absolute position linear mode position offset (lower 32 bits)	-2147483648~2147483647	Encoder unit	0	Effective immediately	Stop setting	ALL
P05-48	Absolute position linear mode position offset (upper 32 bits)	-2147483648~2147483647	Encoder unit	0	Effective immediately	Stop setting	ALL
P0B-07	Absolute position counter	-	Command unit	-	-	display	PST

P0B-58	Mechanical absolute position (lower 32 bits)	-	Encoder unit	0	-	display	ALL
P0B-60	Mechanical absolute position (upper 32 bits)	-	Encoder unit	0	-	display	ALL
P0B-77	Absolute encoder absolute position (lower 32 bits)	-	Encoder unit	0	-	display	ALL
P0B-79	Absolute encoder absolute position (upper 32 bits)	-	Encoderunit	0	-	display	ALL

This mode is mainly used for situations where the load travel range of the equipment is fixed and the multi-turn data of the encoder will not overflow, as shown in the following figure for the ball screw drive mechanism.

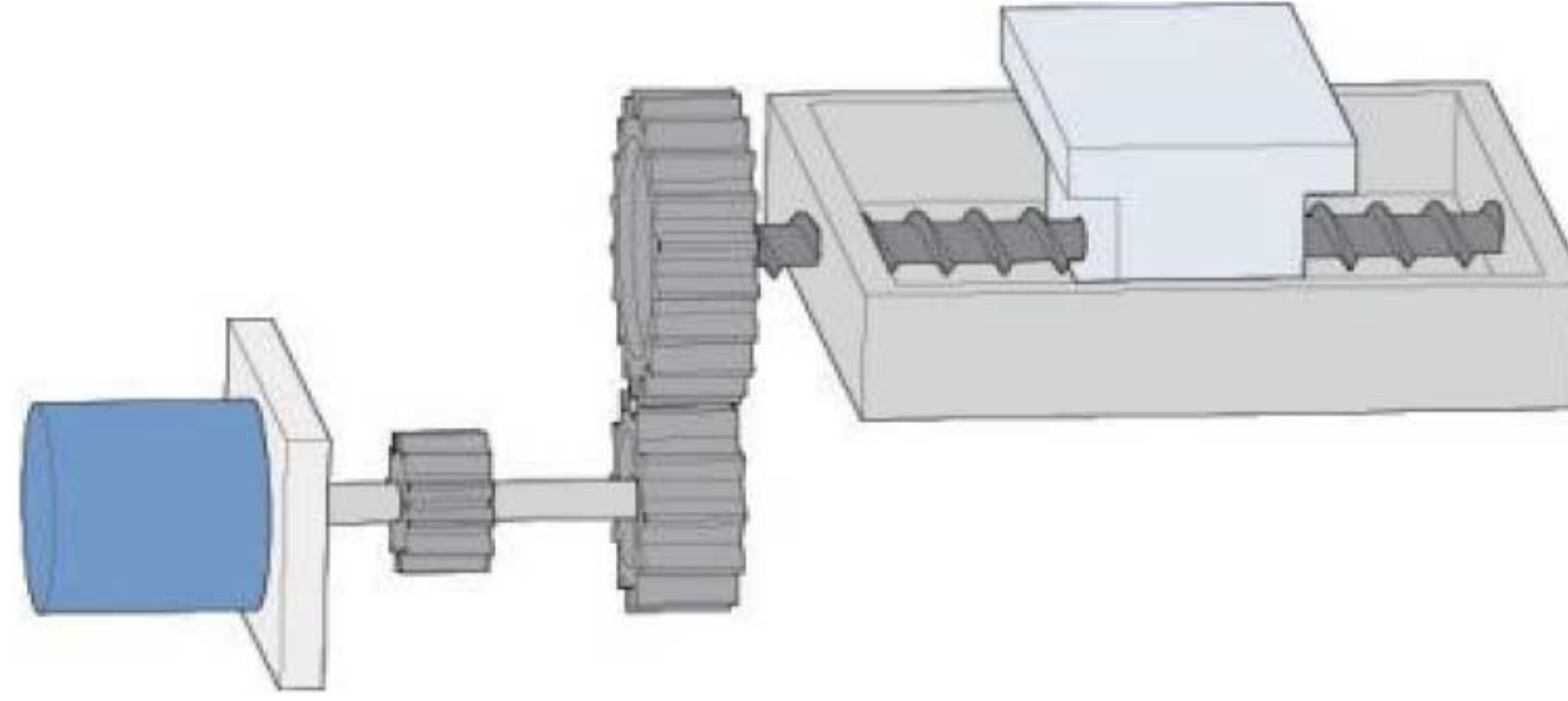

Figure 4-12 Schematic diagram of ball screw transmission mechanism

Assuming that the mechanical absolute position (P0B-58 and P0B-60) is, the encoder absolute position is [range $\sim(-1)$], and the absolute position linear mode position offset (P05-46 and P05-48) is, then the three The relationship is $=-$.

Assuming that the electronic gear ratio is B/A, the absolute position counter (P0B-07) represents the current absolute position of the machine (command unit), $P0B-07=/(B/A)$

In absolute position linear mode, the default position offsets P05-46 and P05-48 are 0, and the drive's origin return function is enabled. After the origin return, the drive automatically calculates the encoder absolute position and the mechanical absolute position deviation and assigns them to P05-46 and P05-48 and stored in EEPROM.

The multi-turn data range of the encoder in absolute position linear mode is $-32768\sim32767$. If the forward rotation number is greater than 32767 or the reverse rotation number is less than -32768 , the FU. 735 encoder multi-turn count overflow fault will occur, which can be set by setting P0A-36 Mask this fault.

3.Absolute position rotation mode

Function code	Name	Setting range	Unit	Default	Valid way	Set way	Relative model
P05-50	Absolute Position Rotation Mode Mechanical Gear Ratio (Numerator)	1-65535	-	65535	Effective immediately	Stop setting	ALL
P05-51	Absolute position rotation mode mechanical gear ratio (denominator)	1-65535	-	1	Effective immediately	Stop setting	ALL
P05-52	The number of pulses for one rotation of the load in absolute position rotation mode (encoder unit is lower 32 bits)	0~4294967295	Encoder unit	0	Effective immediately	Stop setting	PST
P05-54	The number of pulses for one rotation of the load in absolute position rotation mode (encoder unit high 32 bits)	0~127	Encoder unit	0	Effective immediately	Stop setting	ALL
P0B-07	Absolute position counter	-	Instruction unit	-	-	display	ALL
P0B-58	Mechanical absolute position (lower 32 bits)	-	Encoder unit	0	-	display	ALL

P0B-60	Mechanical absolute position (high 32 bits)	-	Encoder unit	0	-	display	ALL
P0B-77	Absolute encoder absolute position (lower 32 bits)	-	Encoder unit	0	-	display	ALL
P0B-79	Absolute encoder absolute position (upper 32 bits)	-	Encoder unit	0	-	display	ALL
P0B-81	Rotating load single-turn position (lower 32 bits)	-	Encoder unit	0	-	display	ALL
P0B-83	Rotating load single-turn position (upper 32 bits)	-	Encoder unit	0	-	display	ALL
P0B-85	Rotating load single-turn position	-	Instruction unit	0	-	display	ALL

This mode is mainly used for the unrestricted range of the equipment load stroke. When the power is off, the number of rotations of the motor in one direction is less than 32767, as shown in the figure below to rotate the load.

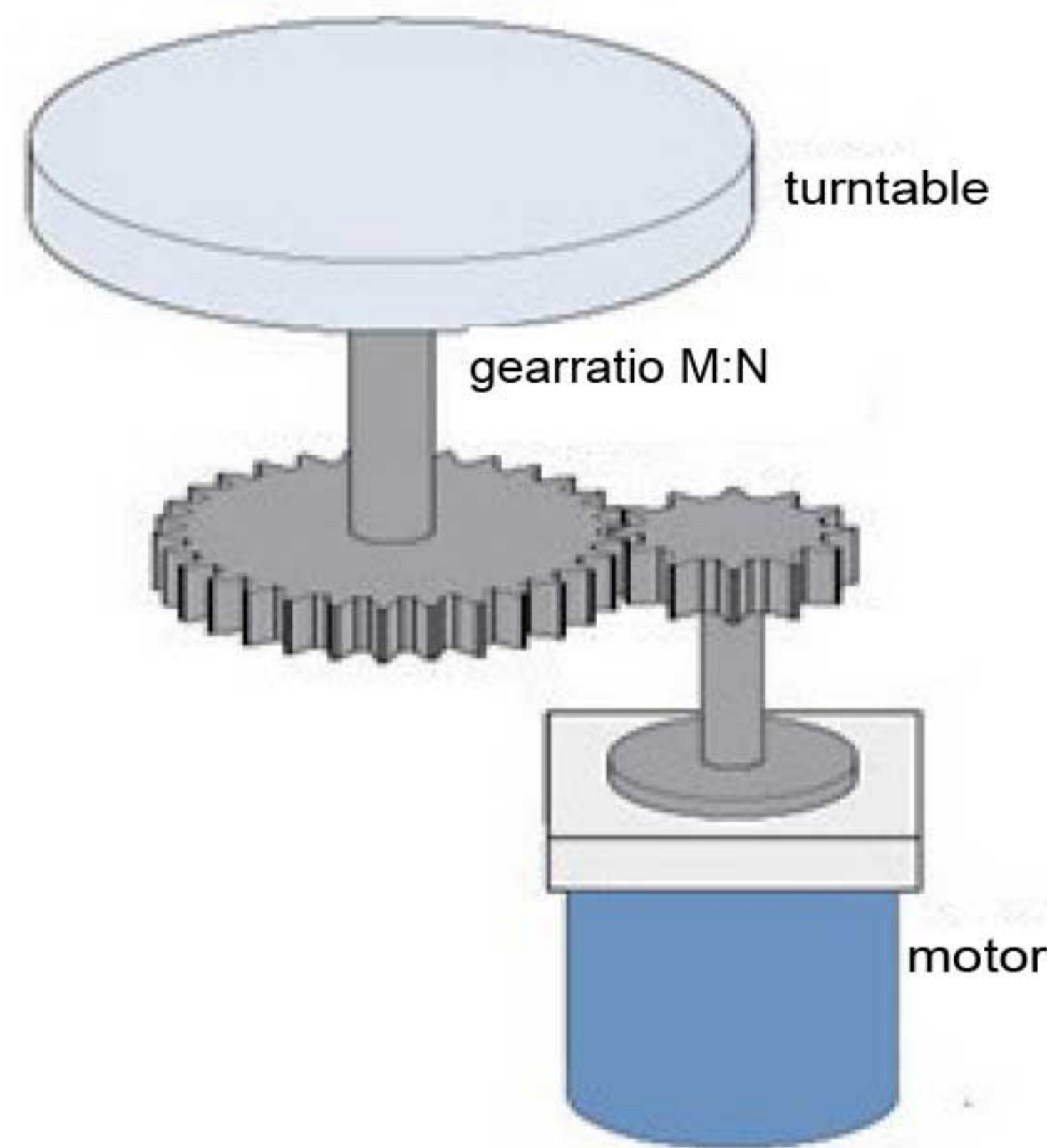

Figure 4-13 Schematic diagram of rotating load

P05-52 and P05-54 are preferentially used to calculate the upper limit of the mechanical absolute position in the drive. When both P05-52 and P05-54 are 0, the mechanical gear ratio P05-50 and P05-51 are used for calculation. Assuming the encoder resolution (Δ), assuming that the encoder pulse number corresponding to one rotation of the load is, when P05-52 or P05-54 is not equal to 0, $\Delta = P05-54 \times P05-52$; P05-52, P05-54 are all 0, $\Delta =$.

Assuming that the electronic gear ratio is Δ , the absolute position counter (P0B-17) represents the current absolute position of the machine (command unit), $P0B-17 =$.

The corresponding relationship between the single-turn position of the rotating load and the position of the turntable is shown in the figure below:

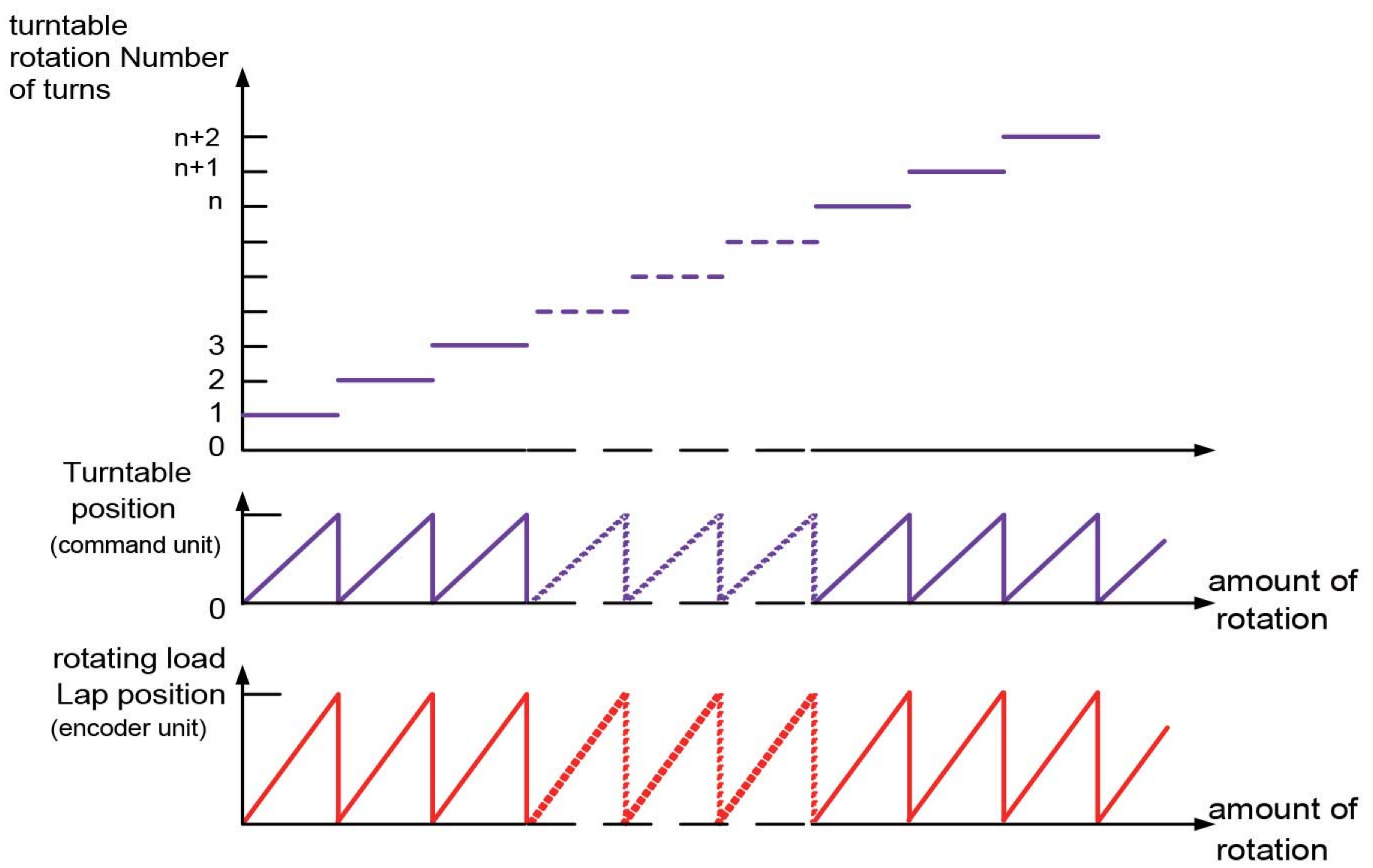

Figure 4-14 Schematic diagram of the correspondence between the position of a single turn of the rotating load and the position of the turntable

The relationship between encoder feedback position and rotating load single turn is shown in the figure below:

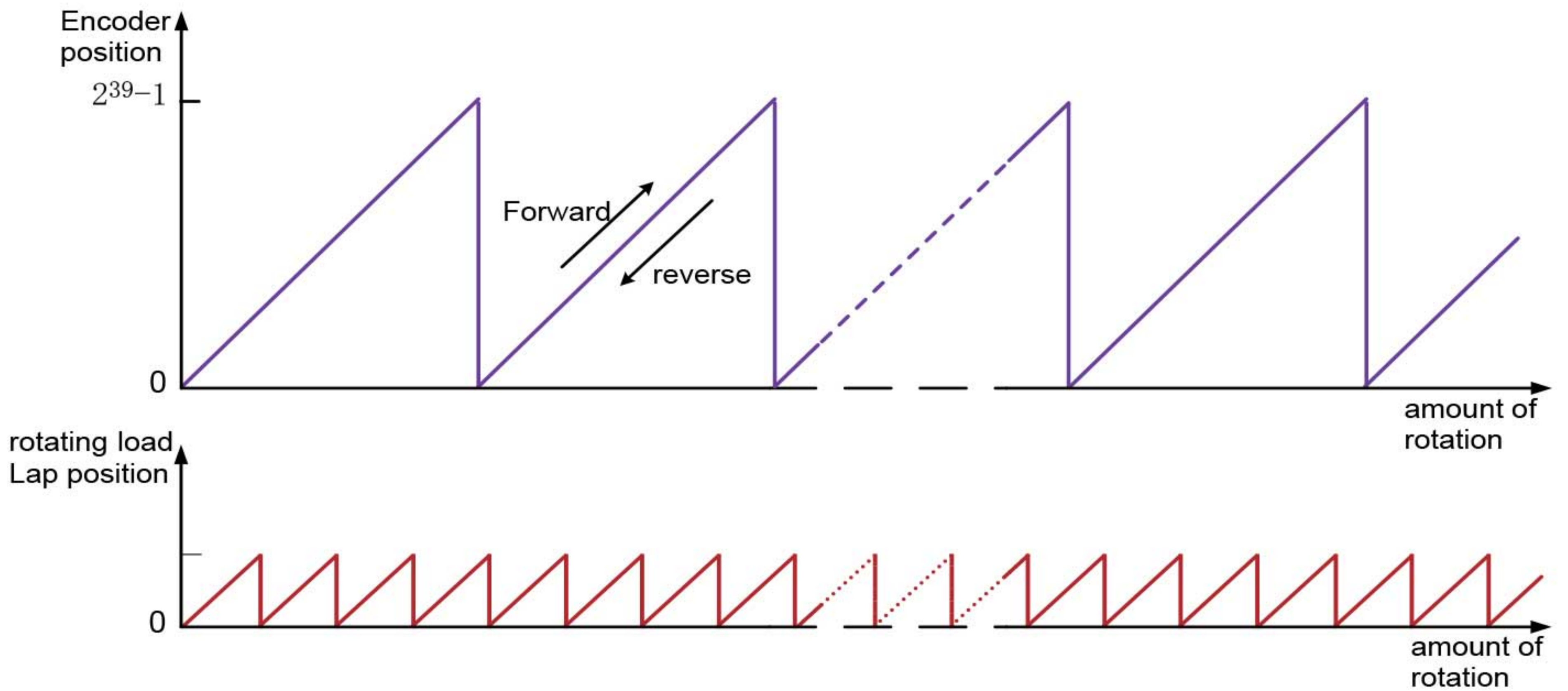

Figure 4-15 Schematic diagram of the correspondence

Unlimited multi-turn data range in absolute position rotation mode, shielding FU. 735 encoder multi-turn count overflow fault.

1. Encoder feedback data

Absolute encoder feedback data can be divided into encoder rotation number data and encoder position within 1 circle, incremental position mode without encoder rotation circle data feedback.

Function code	Name	Setting range	Unit	Default	Valid way	Set way	Relative model
P0B-70	Absolute encoder rotation data	-	r	0	-	display	ALL
P0B-71	Position within 1 revolution of absolute encoder	-	Encoder unit	0	-	display	ALL

2. Encoder multi-turn overflow fault selection

In absolute position linear mode, set P0A-36 to shield the encoder multi-turn overflow fault.

Function code	Name	Setting range	Unit	Default	Valid way	Set way	Relative model
P0A-36	Encoder multi -turn overflow fault selection	0: not shield 1: Shield	-	0	Effective immediately	Stop set	ALL

3. Absolute encoder reset operation

Reset encoder internal fault or reset encoder feedback multi-turn data by setting P0D-20.

Function code	Name	Setting range	Unit	Default	Valid way	Set way	Relative model
P0D-20	Absolute encoder reset operation	0 - no operation 1-Reset fault 2- Reset fault and multi-turn data	-	0	Effective immediately	Stop set	ALL

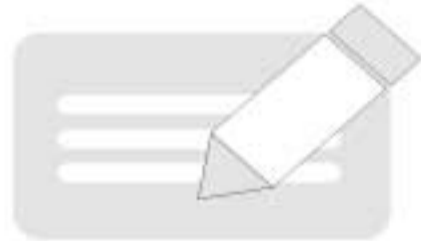

- ◆ After the reset encoder feedback multi-turn data operation, the absolute position of the encoder changes abruptly, and the mechanical origin return operation is required.

4.4.3 Precautions for using the battery box of the absolute value system

FU.731 (encoder battery fault) will occur when the battery is connected for the first time. It is necessary to set P0D-20=1 to reset the encoder fault, and then perform the absolute position system operation.

When the detected battery voltage is less than 3.0V, FU.730 (encoder battery warning) will occur, please replace the battery. The replacement method is as follows:

Step 1: The drive is powered on and is in a non-running state;

Step 2: Replace the battery;

Step 3: After the driver automatically releases FU.730 (encoder battery warning), there is no other abnormal warning, and it can run normally.

Notice:

- ◇ In the case of servo power failure, FU.731 (encoder battery failure) will occur when the battery is replaced and the power is turned on again, and the multi-turn data changes abruptly. Please set P0D-20=1 to reset the encoder failure, and perform the return-to-origin function operation again;
- ◇ When the drive is powered off, please ensure that the maximum speed of the motor does not exceed 6000rpm to ensure that the encoder position information is accurately recorded;
- ◇ During storage, please store at the specified ambient temperature, and ensure that the battery has reliable contact and sufficient power, otherwise the encoder position information may be lost.

4.5 Soft limit function

- ◇ Traditional hardware limit function: In the traditional method, the limit position can only be given by an external signal, and the external sensor signal is connected to the CN1 interface of the servo drive.

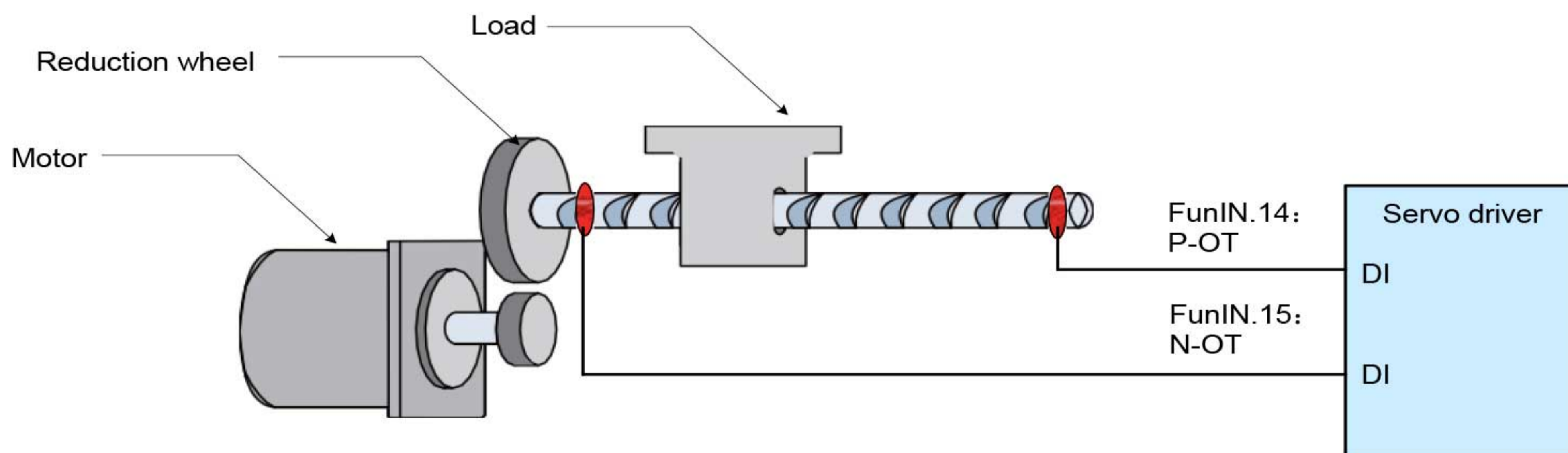

Figure 4-16 Installation diagram of limit switch

Soft limit function: It refers to comparing the position feedback with the set limit value through the drive, when it exceeds the limit value, it will alarm immediately and execute stop operation. This function can be used in both absolute position mode and incremental position mode. In incremental position mode, you need to set P0A-40=2. After the drive is powered on, it will first perform the origin return to find the machine origin, and then enable the software limit function.

Sheet 4-5 Comparison of advantages and disadvantages of traditional hardware limit and soft limit functions:

Traditional hardware limit function		software limit function	
1	Only limited to linear motion, single-turn rotary motion	1	Not only can be used in linear motion, but also in rotary mode
2	Requires external installation of mechanical limit switches	2	No hardware wiring is required to prevent misoperation caused by poor line contact
3	Unable to judge abnormal mechanical slip	3	Internal position comparison to prevent mechanical slippage resulting in abnormal movement
4	When the power is turned off, the machine moves out of the limit position, which cannot be judged or alarmed.		

Function code	Name	Setting range	Unit	Default	Valid way	Set way	Relative model
P0A-40	Soft limit setting	0-disable soft limit 1-Enable software limit immediately after power-on 2-Enable soft limit after origin return	1	0	Effective immediately	Stop set	PST
P0A-41	Absolute position limit maximum value	-2147483648~2147483647	instruction unit	2147483647	Effective immediately	Stop set	PST
P0A-43	Absolute position limit min. value	-2147483648~2147483647	instruction unit	-2147483648	Effective immediately	Stop set	PST

■ When P0A-40=0, the soft limit function is disabled;

■ When P0A-40=1, the software limit function is enabled immediately after the drive is powered on. When the absolute position counter (P0B-07) is greater than P0A-41, the FU.950 warning occurs, and the positive overtravel stop is executed; when the absolute position counter (P0B-07) is smaller than the P0A-43, the FU.952 warning occurs, and the negative overtravel is executed. shutdown;

■ When P0A-40=2, the software limit is not enabled before the origin return after the drive is powered on. After the origin return, when the absolute position counter (P0B-07) is greater than P0A-41, a FU.950 warning will occur, and the forward overtravel will be executed. Stop; when the absolute position counter (P0B-07) is less than P0A-43 after the origin return, a FU.952 warning occurs, and the forward overtravel stop is performed.

4.6 Pre-run Check

Please first disengage the load connected to the servo motor, the coupling connected to the servo motor shaft and its related accessories. Ensure that the servo motor can work normally without load, and then connect the load to avoid unnecessary danger.

- 1) Before running, please check and make sure:
- 2) There is no obvious damage to the appearance of the servo drive;
- 3) The wiring terminals have been insulated;
- 4) There are no conductive objects or flammable objects such as screws or metal sheets inside the driver, and there are no conductive foreign objects at the wiring ports;
- 5) Servo drives or external braking resistors are not placed on combustible objects;
- 6) The wiring is completed and correct: the wiring of the driver power supply, auxiliary power supply, grounding terminal, etc. is correct; the wiring of each control signal cable is correct and reliable; all limit switches and protection signals have been correctly connected.
- 7) The enable switch has been placed in the OFF state;
- 8) Cut off the power circuit and the emergency stop alarm circuit to keep the access;
- 9) The applied voltage reference of the servo drive is correct.
- 10) Power on the servo drive when the controller does not send a running command signal. Check and guarantee:
- 11) The servo motor can rotate normally without vibration or excessive running sound;
- 12) All parameters are set correctly. Unexpected actions may occur according to different mechanical characteristics, please do not set excessively extreme parameters;
- 13) There is no abnormality between the bus voltage indicator and the digital tube display.

4.7 Load inertia identification and gain adjustment

First, please install and wire it correctly. After completing the relevant functional parameter settings, refer to Figure 4-17 for the use process to debug the inertia identification, rigidity table, and vibration suppression.

Inertia identification (see 4.7.1 for details), after obtaining the correct load inertia ratio, it is recommended to perform automatic gain adjustment first, if the effect is not good, then perform manual gain adjustment (see 4.7.2 for details).

The mechanical resonance is suppressed by a notch filter, and two resonance frequencies can be set (see 4.7.2 for details). The general debugging process is shown in the following flowchart.

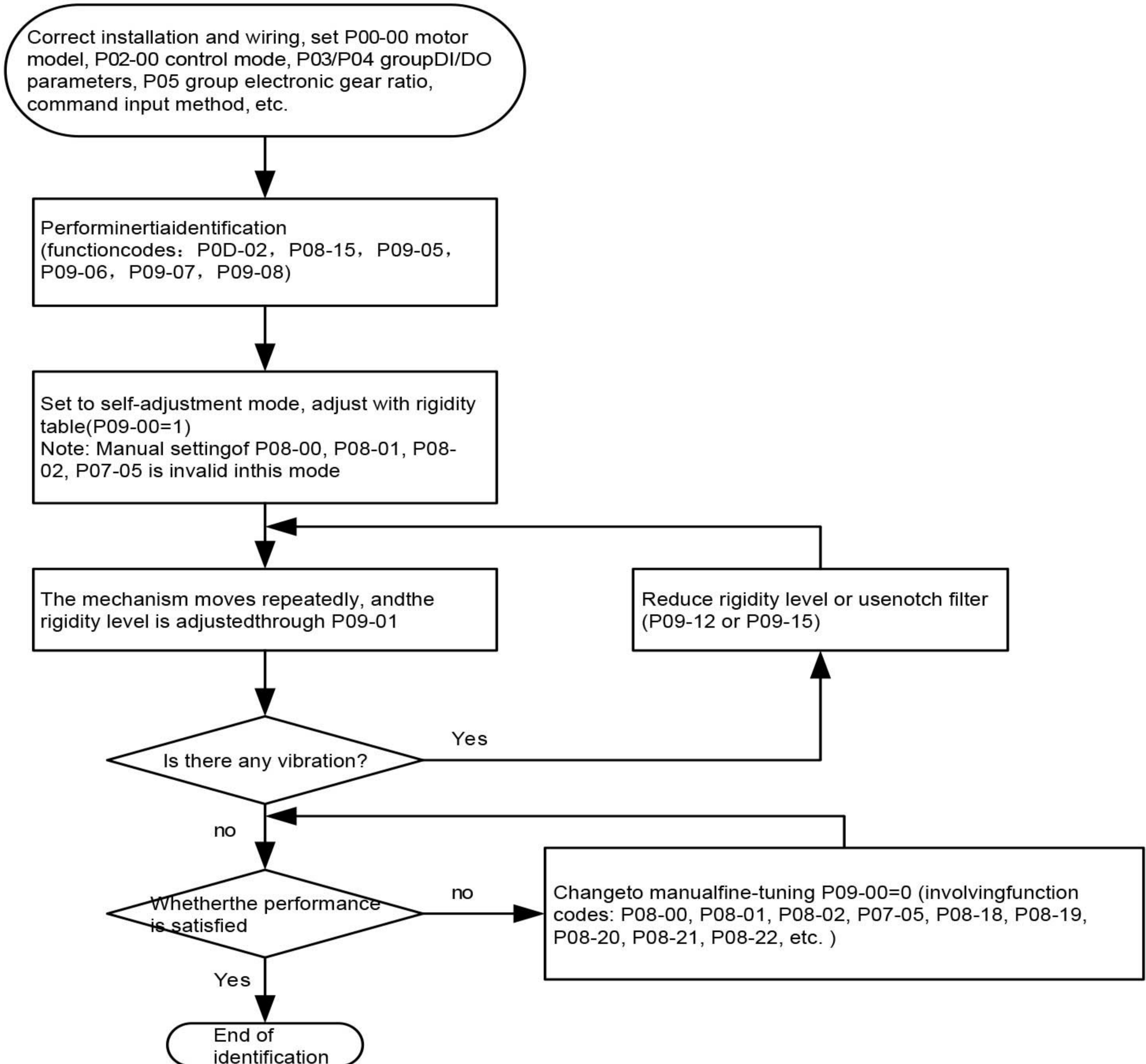

Figure 4-17 General debugging flow chart

4.7.1 Inertia identification

Before automatic gain adjustment or manual gain adjustment, inertia identification is required to obtain the real load inertia ratio. The flow chart of inertia identification is as follows:

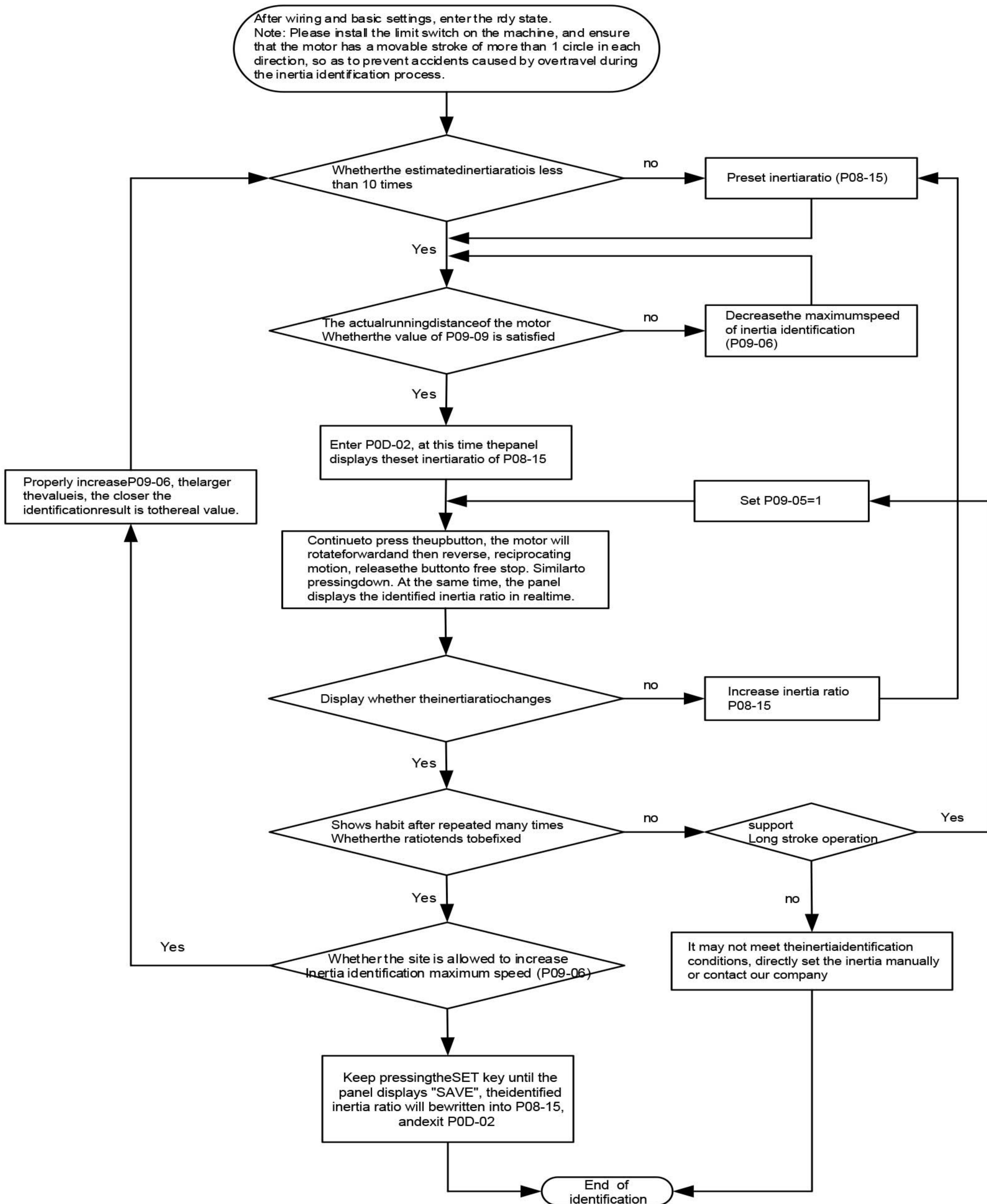
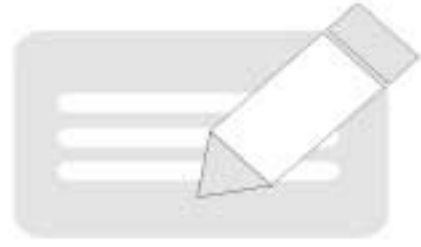

Figure 4-18 Inertia identification debugging flow chart



- ◆ If the default value of P08-15=1, the actual speed cannot keep up with the command because the inertia ratio is too small, which makes the identification fail. At this time, it is necessary to preset the “ average value of the last output of inertia identification” (P08-15). The preset value is recommended to be 5 times as the starting value, and gradually increase until it can be recognized normally.
- ◆ In the offline inertia identification mode, it is generally recommended to use the triangle wave mode. If the identification effect is not good, try the step square wave mode.
- ◆ When P09-05=1, pay attention to the mechanical stroke to prevent accidents caused by overtravel during the offline inertia identification process.

☆The relevant function codes are as follows:

Function code	Name	Setting range	Unit	Factory setting	Effective way	Setting way	Related patterns
P09-05	Offline inertia identification mode selection	0-positive and negative triangle wave mode 1-JOG jog mode 2-Two-way identification mode 3-One-way identification mode	-	0	Effective immediately	stop setting	PST
P09-06	Inertia identification maximum speed	100~1000	rpm	500	Effective immediately	stop setting	PST
P09-07	Accelerate to maximum speed time constant during inertia identification	20~800	ms	125	Effective immediately	stop setting	PST
P09-08	Waiting time after a single inertia identification is completed	50~10000	ms	800	Effective immediately	stop setting	PST
P09-09	Complete the single inertia identification of the number of revolutions of the motor	0.00~2.00	r	-	-	display	PST

Conditions for valid inertia identification:

- The actual maximum speed of the motor is higher than 150rpm;
- Acceleration during actual acceleration and deceleration is above 3000rpm/s;
- The load torque is relatively stable and cannot change drastically;
- Maximum identifiable inertia is 120 times;
- Identification failure may occur when the mechanical rigidity is extremely low or the backlash of the transmission

mechanism is large.

4.7.2 Manual gain adjustment

During manual gain adjustment, it is necessary to set P09-00 to 0, and then adjust several gain-related parameters separately.

Increasing the gain of the position loop and the gain of the speed loop will make the response of the system faster, but too large a gain will cause the system to become unstable. In addition, under the premise that the load inertia ratio is basically accurate, the speed loop gain and the position loop gain should satisfy a certain relationship, as shown below, otherwise the system will easily become unstable.

$$\frac{1}{3} \leq \frac{P08-00[Hz]}{P08-02[Hz]} \leq 1$$

Increasing the torque command filter time P07-05 is helpful to suppress the mechanical resonance, but it will reduce the response of the system. Relative to the speed loop gain, the filter time cannot be increased arbitrarily, and the following conditions should be met:

$$P08-00 \leq \frac{1000}{2\pi \times P07-05 \times 4}$$

☆ The relevant function codes are as follows:

Function code	Name	Setting range	Unit	Factory setting	Effective way	Setting way	Related patterns
P08-00	Speed loop gain	0.1~2000.0	Hz	25.0	Effective immediately	Run setting	PST
P08-01	Speed loop integral time constant	0.15~512.00	ms	31.83	Effective immediately	Run setting	PST
P08-02	Position loop gain	0.0~2000.0	Hz	40.0	Effective immediately	Run setting	PST
P07-05	Torque command filter time constant	0.00~30.00	ms	0.79	Effective immediately	Run setting	PST

4.7.4 Notch filter

- The mechanical system has a certain resonance frequency. If the servo gain is set too high, resonance may occur near the mechanical resonance frequency. In this case, consider using a notch filter. The notch filter suppresses the mechanical resonance by reducing the gain of a specific frequency, so the gain can be set higher.
- There are 4 groups of notch filters, and each group of notch filters has 3 parameters, namely frequency, width level and attenuation level. When frequency is default
- At 4000Hz, the notch filter is actually invalid. The first and second groups of notch filters are manual notch filters, and each parameter is manually set by the user.
- The third and fourth groups of notch filters are adaptive notch filters. When the adaptive filter mode is turned on, it is set by the driver itself. If the adaptive filter mode is not turned on, it can also be set manually.
- The mode of adaptive notch filter is controlled by function code P09-02. When P09-02 is set to 1, the third group of notch filters is valid. When the servo is enabled and resonance is detected, the parameters will be automatically set to suppress vibration. When P09-02 is set to 2, the 3rd and 4th groups of notch filters are effective together, and both groups of notch filters can be set automatically.
- If using a notch filter to suppress resonance, use an adaptive notch filter first. If the adaptive notch filter is ineffective or not working well, a manual notch filter can be used. When using a manual notch filter, set the frequency parameter to the actual resonant frequency. This frequency can be obtained by the mechanical characteristic analysis tool of the background software. It is recommended to keep the default value of 2 for the width level. The depth level is adjusted according to the situation. The smaller this parameter is set, the stronger the effect of suppressing resonance. The larger the setting, the weaker the suppressing effect. If it is set to 99, it has almost no effect. Although lowering the depth level will increase the suppression effect, it will also cause phase lag, which may make the system unstable, so it should not be lowered arbitrarily.

4.8 Background software

The company's website: www.chinaoulu.com, provides free download and use of the background software. With the PC communication cable provided by the company, the personal computer can communicate with the servo drive. The communication cable can also be self-made, see the wiring chapter for the wiring method.

The background software has the following functions:

1. Oscilloscope, which can detect and save instantaneous data during servo operation.
2. Parameter management, can read and download parameters in batches.
3. The database can correctly identify the function codes of some non-standard software.
4. Inertia identification, the load inertia ratio can be identified through a series of actions.
5. Motion JOG, a position command can be planned to make the motor run repeatedly.
6. The background software supports WindowsXP and Windows7 operating systems. For the detailed usage of the background software, please refer to the help file of the background software.

Chapter 5 Parameter summary

Function code	Data specifications	Function code	Data specifications
P00 group	Servo motor parameters	P0Agroup	Fault and protection parameters
P01 group	Drive parameters	P0B group	Monitoring parameters
P02 group	Basic control parameters	P0C group	Communication parameters
P03 group	Terminal input parameters	P0D group	Auxiliary function parameters
P04 group	Terminal output parameters	P0F group	Full closed loop function parameters
P05 group	Position control parameters	P11 group	Multi-segment position function parameters
P06 group	Speed control parameters	P12 group	Multi-stage speed parameters
P07 group	Torque control parameters	P17 group	Virtual DIDO parameters
P08 group	Gain parameters	P30 group	Communication read servo related variables
P09 group	Self-tuning parameters	P31 group	Communication given servo related variables

P00 Group Servo motor data sheet

Function code	Name	Setting range	Unit	Factory setting	Effective way	Setting way	Related patterns
P00 00	Motor number	14130: Domochuan absolute encoder motor 22□□□: 220VClass Incremental Encoder Motor	-	14130	Re-energize	Stop setting	ALL
P00 02	Non-standard	-	-	-	-	Display	-
P00 04	Encoder version number	-	-	-	-	Display	-
P00 05	Bus Motor Number	-	-	-	-	Display	-
P00 08	Absolute Encoder Type	14100: Multi-loop absolute encoder Other: Single-loop absolute encoder	-	-	Re-energize	Stop setting	ALL
P00 09	Rated voltage	0-220	V	-	Re-energize	Stop setting	-
P00 10	Rated power	0.01~655.35	kW	-	Re-energize	Stop setting	-
P00 11	Rated current	0.01~655.35	A	-	Re-energize	Stop setting	-
P00 12	Rated torque	0.01~655.35	Nm	-	Re-energize	Stop setting	-
P00 13	Max torque	0.10~655.35	Nm	-	Power up again	Stop setting	-
P00 14	Rated speed	100~6000	rpm	-	Power up again	Stop setting	-
P00 15	Max speed	100~6000	rpm	-	Power up again	Stop setting	-
P00 16	rotary inertia Jm	0.01~655.35	kgcm2	-	Power up again	Stop setting	-
P00 17	Number of pole pairs of PMSM	2~360	Opposite	-	Power up again	Stop setting	-
P00 18	stator resistance	0.001~65.535	Ω	-	Power up again	Stop setting	-
P00 19	Stator Inductance Lq	0.01~655.35	mH	-	Power up again	Stop setting	-
P00 20	Stator Inductance Ld	0.01~655.35	mH	-	Power up again	Stop setting	-

Function code		Name	Setting range	Unit	Factory setting	Effective way	Setting way	Related patterns
P00	21	Linear back EMF coefficient	0.01~655.35	mV/rpm	-	Power up again	Stop setting	-
P00	22	Moment coefficient Kt	0.01~655.35	Nm/Arms	-	Power up again	Stop setting	-
P00	23	Electrical constant Te	0.01~655.35	ms	-	Power up again	Stop setting	-
P00	24	Mechanical constant Tm	0.01~655.35	ms	-	Power up again	Stop setting	-
P00	28	Position offset of absolute encoder	0~1073741824	P/r	-	Power up again	Stop setting	-
P00	30	Encoder Selection (HEX)	0x010-17bit 0x016-23bit	1	0x010	Power up again	Stop setting	-
P00	31	PPR of encoder	0~1073741824	P/r	131072	Power up again	Stop setting	-
P00	33	Electrical angle of Signal Z	0.0~360	°	180	Power up again	Stop setting	-
P00	34	Electrical angle of phase U rise edge	0.0~360	°	180	Power up again	Stop setting	-

P01 Group Servo Drive Datasheet

Function code		Name	Setting range	Unit	Factory setting	Effective way	Setting way	Related patterns
P01	00	MCU Software Version Number	0~65535	-	-	-	Display	-
P01	01	FPGA Software Version Number	0~65535	-	-	-	Display	-
P01	02	Servo Drive SN	0~65535	-	-	Power up again	Stop setting	-

P02 Group Basic control parameters

Function code		Name	Setting range	Unit	Factory setting	Effective way	Setting way	Related patterns
P02	00	Control Mode Selection	0: Speed mode 1: position mode 2: Torque mode 3: Torque mode↔speed mode 4: Speed mode↔Position mode 5: Torque mode↔Position mode 6: Torque mode↔speed↔position hybrid mode	-	1	Effective immediately	Stop setting	-
P02	01	Absolute value system selection	0: Incremental Location Mode 1: Absolute Position Linear Mode 2: Absolute position rotation mode	-	0	Power up again	Stop setting	ALL
P02	02	rotating direction selection	0: take the CCW direction as the positive direction (A lead B) 1: in CW direction (reversal mode,Alag B)	-	0	Power up again	Stop setting	PST
P02	03	Output pulse phase	0: take the CCW direction as the positive direction (A lead B) 1: in CW direction (reversal mode,Alag B)	-	0	Power up again	Stop setting	PST

Function code	Name	Setting range	Unit	Factory setting	Effective way	Setting way	Related patterns
P02	05	stop model at S-ON off		0	Effective immediately	Stop setting	PST
P02	06	Fault No.2 Stop Mode Selection		0	Effective immediately	Stop setting	PST
P02	07	Choice of Overhaul Mode		1	Effective immediately	Stop setting	PST
P02	08	Fault No.1 Stop Mode Selection		0	Effective immediately	Stop setting	PST
P02	09	delay from brake output ON to command received	ms	250	Effective immediately	Run settings	PS
P02	10	delay from brake output OFF to motor de-energized in static state	ms	150	Effective immediately	Run settings	PS
P02	11	motor speed threshold at brakeoutput OFF in rotating state	rpm	30	Effective immediately	Run settings	PS
P02	12	Rotate state, motor does not power to lock output OFF delay	ms	500	Effective immediately	Run settings	PS
P02	15	LED Warning Display Select		0	Effective immediately	Stop setting	PST
P02	18	Servo Enable (S-ON) Filter time constant	ms	0	Effective immediately	Stop setting	PST
P02	21	Brake resistance minimum allowed by driver	Ω	-	-	Display	PST
P02	22	Built-in Brake Resistance Power	W	-	-	Display	PST
P02	23	Built-in brake resistance	Ω	-	-	Display	PST
P02	24	Resistance heat dissipation factor	%	30	Effective immediately	Stop setting	PST
P02	25	Brake resistance settings		0	Effective immediately	Stop setting	PST
P02	26	External brake resistance power	W	-	Effective immediately	Stop setting	PST
P02	27	External brake resistance resistance	Ω	-	Effective immediately	Stop setting	PST
P02	30	User password		0	Power up again	Stop setting	PST

Function code	Name	Setting range	Unit	Factory setting	Effective way	Setting way	Related patterns
P02	31	System parameter initialization	0: no operation 1: Recovery of factory setting (except P00/P01 sets of parameters) 2 : troubleshooting records	-	0	Effective immediately	Stop setting PST
P02	32	Panel Default Display	0~99	-	50	Effective immediately	Run settings -
P02	38	Fault short circuit braking time	0~30000	ms	5000	Effective immediately	Run settings PST

P03 Group Terminal input parameters

Function code	Name	Setting range	Unit	Factory setting	Effective way	Setting method	Related patterns
P03	00	Effective DI function distribution 1	0~0xFFFF Bit0: correspond FunIN.1 Bit1; correspond FunIN.2 Bit15: correspond FunIN.16	-	0	Power up again	Run settings -
P03	01	Effective DI function distribution 2	0~0xFFFF Bit0: correspond FunIN.17 Bit1: correspond FunIN.18 Bit15: correspond FunIN.32	-	0	Power up again	Run settings -
P03	02	DI1 Terminal function selection	0~37	-	14	Outage takes effect	Run settings -
P03	03	DI1 Terminal logic selection	Input polarity :0~4 0: means low level valid 1: indicates high level of efficiency 2 : indicates that the rising edge is effective 3: indicates that the decline is effective 4 : indicates that the rising and falling edges are effective	-	0	Outage takes effect	Run settings -
P03	04	DI2 Terminal function of selection	0	-	15	Outage takes effect	Run settings -
P03	05	DI2 Terminal logic selection	Input polarity :0~4 0: means low level valid 1: indicates high level of efficiency 2 : indicates that the rising edge is effective 3: indicates that the decline is effective 4: indicates that the rising and falling edges are effective	-	0	Outage takes effect	Run settings -
P03	06	DI3 Terminal function election	0~37	-	13	Outage takes effect	Run settings -
P03	07	DI3 Terminal logic selection	Input polarity :0~4 0: means low level valid 1: indicates high level of efficiency 2 : indicates that the rising edge is effective 3: indicates that the decline is effective 4: indicates that the rising and falling edges are effective	-	0	Outage takes effect	Run settings -

Function code		Name	Setting range	Unit	Factory setting	Effective way	Setting method	Related patterns
P03	08	DI4 Terminal function selection	0	-	2	Outage takes effect	Run settings	-
P03	09	DI4 Terminal logic selection	Input polarity :0~4 0: means low level valid 1: indicates high level of efficiency 2: indicates that the rising edge is effective 3: indicates that the decline is effective 4: indicates that the rising and falling edges are effective	-	0	Outage takes effect	Run settings	-
P03	10	DI5 Terminal function selection	0~37	-	1	Outage takes effect	Run settings	-
P03	11	DI5 Terminal logic selection	Input polarity :0~4 0: means low level valid 1: indicates high level of efficiency 2: indicates that the rising edge is effective 3: indicates that the decline is effective 4: indicates that the rising and falling edges are effective	-	0	Outage takes effect	Run settings	-
P03	12	DI6 Terminal function selection	0~37	-	12	Outage takes effect	Run settings	-
P03	13	DI6 Terminal logic selection	Input polarity :0~4 0: means low level valid 1: indicates high level of efficiency 2: indicates that the rising edge is effective 3: indicates that the decline is effective 4: indicates that the rising and falling edges are effective	-	0	Outage takes effect	Run settings	-
P03	14	DI7 Terminal function selection	0~37	-	3	Outage takes effect	Run settings	-
P03	15	DI7 Terminal logic selection	Input polarity :0~4 0: means low level valid 1: indicates high level of efficiency 2: indicates that the rising edge is effective 3: indicates that the decline is effective 4: indicates that the rising and falling edges are effective	-	0	Outage takes effect	Run settings	-
P03	16	DI8 Terminal function selection	0~37	-	31	Outage takes effect	Run settings	-

Function code	Name	Setting range	Unit	Factory setting	Effective way	Setting method	Related patterns
P03	17	DI8 Terminal logic selection	Input polarity :0~4 0: means low level valid 1: indicates high level of efficiency 2: indicates that the rising edge is effective 3: indicates that the decline is effective 4: indicates that the rising and falling edges are effective	-	0	Outage takes effect	Run settings
P03	18	DI9 Terminal function selection	0~37	-	0	Outage takes effect	Run settings
P03	19	DI9 Terminal logic selection	Input polarity :0~4 0: means low level valid 1: indicates high level of efficiency 2: indicates that the rising edge is effective 3: indicates that the decline is effective 4: indicates that the rising and falling edges are effective	-	0	Outage takes effect	Run settings
P03	34	Effective DI Function Distribution 3	0~0xFFFF Bit0: corresponding FunIN.33 B Bit1: corresponding FunIN.34 Bit15: corresponding FunIN.48	-	0	Power up again	Run settings
P03	35	Effective DI Function Distribution 4	0~0xFFFF Bit0: corresponding FunIN.49 Bit1: corresponding FunIN.50 Bit15: corresponding FunIN.64	-	0	Power up again	Run settings
P03	50	AI1 offset	-5000~5000	mV	0	Effective immediately	Run settings
P03	51	AI1 Input filter time constant	0~655.35	ms	2.00	Effective immediately	Run settings
P03	53	AI1 blind spot	0~1000.0	mV	10.0	Effective immediately	Run settings
P03	54	AI1 drift	-500.0~500.0	mV	0.0	Effective immediately	Run settings
P03	55	AI2 offset	-5000~5000	mV	0	Effective immediately	Run settings
P03	56	AI2 Input filter time constant	0~655.35	ms	2.00	Effective immediately	Run settings
P03	58	AI2 blind spot	0~1000.0	mV	10.0	Effective immediately	Run settings
P03	59	AI2 drift	-500.0~500.0	mV	0.0	Effective immediately	Run settings
P03	80	Analog 10 V corresponding velocity	0rpm~9000rpm	1rpm	3000rpm	Effective immediately	Stop setting
P03	81	Analog 10 V corresponding torque	1.00 times ~8.00 times rated torque	1.00 times rated torque	1.00 times rated torque	Effective immediately	Stop setting

P04 Group Terminal output parameters

Function code	Name	Setting range	Unit	Factory setting	Effective way	Setting method	Related patterns
---------------	------	---------------	------	-----------------	---------------	----------------	------------------

Function code		Name	Setting range	Unit	Factory setting	Effective way	Setting method	Related patterns
P04	00	DO1 Terminal function selection	0~22	-	1	Outage takes effect	Run settings	-
P04	01	DO1 Terminal logic selection	Output polarity reversal settings :0~1 The output L low level when 0: indicates valid (optocoupler conduction) 1: output H high level when valid (optocoupler off)	-	0	Outage takes effect	Run settings	-
P04	02	DO2 Terminal function selection	0~22	-	5	Outage takes effect	Run settings	-
P04	03	DO2 Terminal logic selection	Output polarity reversal settings :0~1 The output L low level when 0: indicates valid (optocoupler conduction) 1: output H high level when valid (optocoupler off)	-	0	Outage takes effect	Run settings	-
P04	04	DO3 Terminal function selection	0~22	-	3	Outage takes effect	Run settings	-
P04	05	DO3 Terminal logic selection	Output polarity reversal settings :0~1 The output L low level when 0: indicates valid(optocoupler conduction) 1: output H high level when valid (optocoupler off)	-	0	Outage takes effect	Run settings	-
P04	06	DO4 Terminal function selection	0~22	-	11	Outage takes effect	Run settings	-
P04	07	DO4 Terminal logic selection	Output polarity reversal settings :0~1 The output L low level when 0: indicates valid (optocoupler conduction) 1:output H high level when valid (optocoupler off)	-	0	Outage takes effect	Run settings	-
P04	08	DO5 Terminal function selection	0~22	-	16	Outage takes effect	Run settings	-
P04	09	DO5 Terminal logic selection	Output polarity reversal settings :0~1 The output L low level when 0: indicates valid (optocoupler conduction) 1: output H high level when valid (optocoupler off)	-	0	Outage takes effect	Run settings	-
P04	22	DO original selection	0~31	-	0	Effective immediately	Stop setting	-
P04	50	AO1 Signal selection	00: motor speed V/1000rpm 1 01: speed instruction (1 V/1000rpm) 02: torque instruction (1 V/100%) 03: position deviation (0.05 V/ instruction unit) 04: position deviation (0.05 V/ encoder unit)05: position instruction speed (1 V/1000rpm) 06: Positioning Completion Instruction (Location completed :5 V Location not completed :0 V) 07: speed feedforward (1 V/1000rpm) 08: AI1 voltage 09: AI2 voltage	-	0	Effective immediately	Run settings	-

Function code	Name	Setting range	Unit	Factory setting	Effective way	Setting method	Related patterns
P04 51	AO1 offset voltage	-10000~10000	mV	5000	Effective immediately	Run settings	-
P04 52	AO1 multiplying power	-99.99 ~99.99	Times	1.00	Effective immediately	Run settings	-
P04 53	AO2 Signal selection	00: motor speed (1 V/1000rpm) 01: speed instruction (1 V/1000rpm) 02: torque instruction (1 V/100%) 03: position deviation (0.05 V/ instruction unit) 04: position deviation (0.05 V/ encoder unit) 05: position instruction speed (1 V/1000rpm) 06: Positioning Completion Instruction (Location completed: 5 V Location not completed : 0 V) 07: speed feedforward (1 V/1000rpm) 08: AI1 voltage 09: AI2 voltage	-	0	Effective immediately	Run settings	-
P04 54	AO2 offset voltage	-10000~10000	mV	5000	Effective immediately	Run settings	-
P04 55	AO2 multiplying power	-99.99 ~99.99	Times	1.00	Effective immediately	Run settings	-

P05 Group Position control parameters

Function code	Name	Setting range	Unit	Factory setting	Effective way	Setting method	Related patterns
P05 00	Location instruction source	0: Pulse Instruction 1: step given 2: multi-segment position instruction given	-	0	Effective immediately	Stop setting	P
P05 01	Pulse instruction input terminal selection	0: low speed 1: High Speed	-	0	Effective immediately	Stop setting	P
P05 02	Number of position instructions per rotation of motor	0 ~1048576	P/r	0	Power up again	Stop setting	P
P05 04	First-order low-pass filter time constant	0~6553.5	ms	0.0	Effective immediately	Stop setting	P
P05 05	Step by step	-9999 ~9999	unit	50	Effective immediately	Stop setting	P
P05 06	Average filter time constant	0.0~128.0	ms	0.0	Effective immediately	Stop setting	P
P05 07	Electronic tooth ratio 1 (Molecules)	1~1073741824	-	131072	Effective immediately	Run settings	P
P05 09	Electronic tooth ratio 1 (denominator)	1~1073741824	-	10000	Effective immediately	Run settings	P
P05 11	Electronic tooth ratio 2 (Molecules)	1~1073741824	-	131072	Effective immediately	Run settings	P
P05 13	Electronic tooth ratio 2 (denominator)	1~1073741824	-	10000	Effective immediately	Run settings	P
P05 15	Pulse instruction pattern	0: pulse direction, positive logic 1: pulse direction, negative logic 2: Aphase B phase orthogonal pulse ,4x frequency	-	0	Power up again	Stop setting	P

Function code	Name	Setting range	Unit	Factory setting	Effective way	Setting method	Related patterns
		3: CW CCW					
P05	16	Clear action selection		0	Effective immediately	Stop setting	P
		0: servo enable OFF and clearance of position deviation in case of failure Remove position deviation pulse 1: OFF of enable and failure 2: enable OFF and clear position deviation through DI input ClrPosErr signal	-				
P05	17	Number of frequency division pulses	P/r	2500	Power up again	Stop setting	-
		35 ~32767					
P05	19	Speed feedforward control selection		1	Effective immediately	Stop setting	P
		0: Speedless Feed 1: Internal Speed Feed 2: use AI1 as a speed feedforward input 3: use AI2 as a speed feedforward input	-				
P05	20	Location Complete Output Condition		0	Effective immediately	Run settings	P
		Output 0: absolute value of position deviation is less than P05-21 When the absolute value of 1: position deviation is less than P05-21 and the filtered position instruction is 0, the output is When the absolute value of 2: position deviation is less than P05-21 and the position instruction before filtering is 0, the output is When the absolute value of 3: position deviation is less than the location completion / approach threshold, and the position instruction filter is 0, at least the P05-60 time is kept valid	-				
P05	21	Location completion threshold	Encoder / Instruction Unit	734	Effective immediately	Run settings	P
		1 ~65535					
P05	22	Positioning proximity threshold	Encoder / Instruction Unit	65535	Effective immediately	Run settings	P
		1 ~65535					
P05	30	Origin Reversion Enable Control		0	Effective immediately	Run settings	P
		0: Close Origin Recovery 1: input the HomingStart signal through the DI to enable the origin recovery function 2: input the HomingStart signal through the DI to enable the electrical return function Activate 3: origin immediately 4: immediate origin recovery 5: Activate Electrical Return Zero 6: origin at current position	-				

Function code	Name	Setting range	Unit	Factory setting	Effective way	Setting method	Related patterns
P05 31	Origin Recovery Mode	0: forward return zero, deceleration point, origin is origin switch 1: reverse return zero, deceleration point, origin is origin switch 2: forward return zero, deceleration point, origin is motor Z signal 3: reverse return zero, deceleration point, origin for motor Z signal 4: forward return zero, deceleration point is origin switch, origin is motor Z signal 5: reverse zero, deceleration point is origin switch, origin is motor Z signal 6: forward return zero, deceleration point, origin is forward overpass switch 7: reverse zero, deceleration point, origin is reverse overpass switch 8: forward return zero, deceleration point is forward overrun switch, origin is motor Z signal 9: reverse return zero, deceleration point is reverse overrun switch, origin is motor Z signal 10: forward to zero, deceleration point, origin is mechanical limit position 11: reverse return zero, deceleration point, origin is mechanical limit position 12: forward return zero, deceleration point is mechanical limit position, origin is motor Z signal 13: reverse zero, deceleration point is mechanical limit position, origin is motor Z signal	-	0	Effective immediately	Stop setting	P
P05 32	Speed of high-speed search for origin switch signal	0~3000	rpm	100	Effective immediately	Run settings	P
P05 33	Speed of low speed search for origin switch signal	0~1000	rpm	10	Effective immediately	Run settings	P
P05 34	Time of acceleration and deceleration when searching origin	0~1000	ms	1000	Effective immediately	Stop setting	P
P05 35	Limit the time to find the origin	0~65535	ms	10000	Effective immediately	Stop setting	P
P05 36	Mechanical origin offset	-1073741824 ~ 1073741824	Instruction unit	0	Effective immediately	Stop setting	P
P05 38	Servo Pulse Output Source Selection	0: encoder frequency division output 1: Pulse command synchronous output 2: frequency division or synchronous output prohibited	-	0	Power up again	Stop setting	P

Function code	Name	Setting range	Unit	Factory setting	Effective way	Setting method	Related patterns
P05 39	Electronic gear ratio switching conditions	0: position instruction (unit only) is 0 and switches after 2.5 m/s 1: real-time switching	-	0	Effective immediately	Stop setting	P
P05 40	Mechanical Origin Offset and Limit Treatment	0: P05-36 is the coordinate after the origin is returned, and the reverse origin is found 1: P05-36 is the relative offset after the origin is returned, and the reverse origin is found after the limit is triggered again to enable the origin to be returned 2: P05-36 is the origin after the return of the coordinates, encounter limit automatic reverse change 3: P05-36 is the relative offset after the origin is returned, the limit is automatically reversed	-	0	Effective immediately	Stop setting	P
P05 41	Z Pulse Output Polarity Selection	0: positive polarity output (Z pulse is high level) 1: negative output (Z pulse low level)	-	1	Power up again	Stop setting	P
P05 43	Position pulse along selection	Active on falling edge Active on rising edge	1	0	Power up again	Run settings	PST
P05 46	Absolute position linear mode position bias (low 32 bits)	-2147483648~2147483647	Encoder unit	0	Effective immediately	Stop setting	ALL
P05 48	Absolute position linear mode position bias (high 32 bits)	-2147483648~2147483647	Encoder unit	0	Effective immediately	Stop setting	ALL
P05 50	Absolute position rotation mode mechanical gear ratio (molecule)	1-65535	-	65535	Effective immediately	Stop setting	ALL
P05 51	Absolute position rotation mode mechanical gear ratio (denominator)	1-65535	-	1	Effective immediately	Stop setting	ALL
P05 52	Absolute position rotation mode load rotation cycle number of pulses (low 32 bits)	0~4294967295	Encoder unit	0	Effective immediately	Stop setting	ALL
P05 54	Absolute position rotation mode load rotation cycle number of pulses (32 bits high)	0~127	Encoder unit	0	Effective immediately	Stop setting	ALL
P05 56	Threshold of zero velocity judgment	0~1000	rpm	2	Effective immediately	Run settings	P
P05 58	Contact Stop Zero Torque Limit	0~300.0	%	100.0%	Effective immediately	Run settings	P
P05 59	Location Completion Window Time	0~30000	ms	1	Effective immediately	Run settings	P
P05 60	Positioning completion retention time	0~30000	ms	0	Effective immediately	Run settings	P
P05 61	Number of divider pulses (32 bits)	0~262143	P/r	0	Power up again	Stop setting	-

P06 Group Speed control parameters

Function code	Name	Setting range	Unit	Factory setting	Effective way	Setting method	Related patterns
P06 00	A Source of Main Speed Instruction	0: Number given (P06-03) 1: AI1 2: AI2	-	0	Effective immediately	Stop setting	S
P06 01	Auxiliary Speed Instruction B Source	0: Number given (P06-03) 1: AI1 2: AI2 3: 0 (neutrality) 4: 0 (neutrality) 5: Multi-segment speed instruction	-	1	Effective immediately	Stop setting	S
P06 02	Speed Instruction Selection	0: A Source of Main Speed Instruction 1: Auxiliary Speed Instruction B Source 2: A+B 3: A/B switch 4: Communications	-	0	Effective immediately	Stop setting	S
P06 03	Speed command keyboard setting	-6000~6000	rpm	200	Effective immediately	Run settings	S
P06 04	Set point speed	0~6000	rpm	100	Effective immediately	Run settings	S
P06 05	Speed command acceleration ramp time constant	0~65535	ms	0	Effective immediately	Run settings	S
P06 06	Speed command acceleration ramp time constant	0~65535	ms	0	Effective immediately	Run settings	S
P06 07	Maximum Speed Threshold	0~6000	rpm	6000	Effective immediately	Run settings	S
P06 08	Forward velocity threshold	0~6000	rpm	6000	Effective immediately	Run settings	S
P06 09	Reverse velocity threshold	0~6000	rpm	6000	Effective immediately	Run settings	S
P06 11	Torque Feedforward Control Selection	0: No torque feed 1: Internal torque feed	-	1	Effective immediately	Run settings	PS
P06 15	Zero fixed speed threshold	0~6000	rpm	10	Effective immediately	Run settings	S
P06 16	Motor rotation speed threshold	0~1000	rpm	20	Effective immediately	Run settings	S
P06 17	Speed consistent signal threshold	0~100	rpm	10	Effective immediately	Run settings	S
P06 18	Speed reaches signal threshold	10~6000	rpm	1000	Effective immediately	Run settings	S
P06 19	Zero speed output signal threshold	1~6000	rpm	10	Effective immediately	Run settings	S

P07 Group Torque control parameters

Torque instruction 100% corresponding to motor rated torque.

Function code	Name	Setting range	Unit	Factory setting	Effective way	Setting method	Related patterns
P07 00	A source of master torque instruction	0: Number given (P07-03) 1: AI1 2: AI2	-	0	Effective immediately	Stop setting	T
P07 01	Auxiliary torque instruction B source	0: Number given (P07-03) 1: AI1 2: AI2	-	1	Effective immediately	Stop setting	T

Function code	Name	Setting range	Unit	Factory setting	Effective way	Setting method	Related patterns
P07	02	Torque Directive Selection	0: Source of main torque command 1: Source of auxiliary torque command B 2: Source of main commandA+ source of auxiliary command B 3: Main command A source/auxiliary command B source switch 4: Communication setting	-	0	Effective immediately	Stop setting T
P07	03	Torque instruction keyboard setting	-300.0~300.0	%	0	Effective immediately	Run settings T
P07	05	Torque instruction filter time constant	0~30.00	ms	0.79	Effective immediately	Run settings PST
P07	06	Second torque instruction filtering time constant	0~30.00	ms	0.79	Effective immediately	Run settings PST
P07	07	Torque limitation sources	0: positive and negative internal torque limits 1: positive and negative external torque limits (using P-CL,N-CL options) 2: T-LMT used as external torque limit input 3: torque limit is the minimum value of positive and negative external torque and external T-LMT (using P-CL,N-CL selection) Switch between 4: positive and negative internal torque limit and T-LMT torque limit (using P-CL,N-CL selection)	-	0	Effective immediately	Stop setting PST
P07	08	T-LMT selection	1: AI1 2: AI2	-	2	Effective immediately	Stop setting PST
P07	09	Positive internal torque limit	0.0~300.0	%	300.0	Effective immediately	Run settings PST
P07	10	Negative internal torque limit	0.0~300.0	%	300.0	Effective immediately	Run settings PST
P07	11	Positive external torque limit	0.0~300.0	%	300.0	Effective immediately	Run settings PST
P07	12	Negative External Torque Limit	0.0~300.0	%	300.0	Effective immediately	Run settings PST
P07	17	Selection of speed limit sources	0: internal speed limits (Speed limit for torque control) 1: V-LMT used as an external speed limit input 2: select the P07-19/P07-20 as an internal speed limit via FunIN.36(V-SEL);	-	0	Effective immediately	Run settings T
P07	18	V-LMT Selection	1: AI1 2: AI2	-	1	Effective immediately	Run settings T
P07	19	Torque control forward speed limit value / torque control speed limit value 1	0~6000	rpm	3000	Effective immediately	Run settings T
P07	20	Negative Speed Limit for Torque Control /	0~6000	rpm	3000	Effective immediately	Run settings T

Function code	Name	Setting range	Unit	Factory setting	Effective way	Setting method	Related patterns
	Speed Limit for Torque Control 2						
P07	21	Torque reaches reference value	0.0~300.0	%	0.0	Effective immediately	Run settings PST
P07	22	Torque reaches effective value	0.0~300.0	%	20.0	Effective immediately	Run settings PST
P07	23	Torque arrives invalid	0.0~300.0	%	10.0	Effective immediately	Run settings PST
P07	40	Speed restricted window in torque mode	0.5~30.0	ms	1.0	Effective immediately	Run settings T

P08 Group Gain class parameters

Function code	Name	Setting range	Unit	Factory setting	Effective way	Setting method	Related patterns
P08	00	speed gain	0.1~2000.0	Hz	25.0	Effective immediately	Run settings PS
P08	01	Speed loop integral time constant	0.15~512.00	ms	31.83	Effective immediately	Run settings PS
P08	02	Position loop gain	0.0~2000.0	Hz	40.0	Effective immediately	Run settings P
P08	03	Second speed loop gain	0.1~2000.0	Hz	40.0	Effective immediately	Run settings PS
P08	04	No.2 Speed loop integral time constant	0.15~512.00	ms	40.00	Effective immediately	Run settings PS
P08	05	No.2 Position loop gain	0.0~2000.0	Hz	64.0	Effective immediately	Run settings P
P08	08	Second Gain Mode Settings	0: The first gain is fixed, and the external DI is used for P/PI switching; 1: Use gain switching according to the conditions of P08-09	-	1	Effective immediately	Run settings PST
P08	09	Gain switching condition selection	0: The first gain is fixed (PS) 1: Use external DI switch (PS) 2: Torque command is large (PS) 3: Large speed command (PS) 4: Speed command change rate is large (PS) 5: Speed command high and low speed threshold (PS) 6: Large position deviation (P) 7: Position command (P) 8: Positioning completed (P) 9: The actual speed is large (P) 10: Position command + actual speed (P)	-	0	Effective immediately	Run settings PST
P08	10	Gain switching delay time	0.0~1000.0	ms	5.0	Effective immediately	Run settings PST
P08	11	Gain Switching Level	0~20000	According to switching conditions	50	Effective immediately	Run settings PST
P08	12	Gain switching delay	0~20000	According to switching conditions	30	Effective immediately	Run settings PST
P08	13	Position gain switching time	0.0~1000.0	ms	3.0	Effective immediately	Run settings P

Function code	Name	Setting range	Unit	Factory setting	Effective way	Setting method	Related patterns
P08 15	Load moment of inertia ratio	0.00~64.00	times	1.00	Effective immediately	Run settings	PST
P08 18	Speed feed filter time constant	0.00~64.00	ms	0.50	Effective immediately	Run settings	P
P08 19	Speed feedforward gain	0.0~100.0	%	0.0	Effective immediately	Run settings	P
P08 20	Torque feed filter time constant	0.00~64.00	ms	0.50	Effective immediately	Stop setting	PS
P08 21	Torque Feedforward Gain	0.0~200.0	%	0.0	Effective immediately	Run settings	PS
P08 22	Speed Feedback Filter Option	0: Disable speed feedback average filtering 1: Speed feedback 2 times average filtering 2: Speed feedback 4 times average filtering 3: Speed feedback 8 times average filtering 4: Speed feedback 16 times average filtering	-	0	Effective immediately	Stop setting	PS
P08 23	Speed feedback low pass filter cutoff frequency	100~4000	Hz	4000	Effective immediately	Run settings	PS
P08 24	Pseudo-differential feedforward control coefficient	0.0~100.0	-	100.0	Effective immediately	Run settings	PS

P09 Group Self-adjusting parameters

Function code	Name	Setting range	Unit	Factory setting	Effective way	Setting method	Related patterns
P09 00	Self adjustment mode selection	0: parameter self-adjustment is invalid, manual adjustment of parameters 1: Parameter self-adjustment mode, use rigidity meter to automatically adjust gain parameters 2: Positioning mode, use rigidity meter to automatically adjust gain parameters	-	0	Effective immediately	Run settings	PST
P09 01	Rigid grade selection	0~31	-	12	Effective immediately	Run settings	PST
P09 02	Adaptive Trap Mode Selection	0: The adaptive notch filter is no longer updated 1: An adaptive notch filter is effective (the third group of notch filters) 2: An adaptive notch filter is effective (Group 3 and 4 notch filter) 3: Only test the resonance point, displayed on P09-24 4: Restore the values of the 3rd and 4th notch filters to the factory state	-	0	Effective immediately	Run settings	PST
P09 03	On-line Inertial Identification Mode	0: Disable online identification 1: Open online recognition, slowly changing 2: Open online identification, general changes 3: Open online recognition, rapid changes	-	0	Effective immediately	Run settings	RST

Function code	Name	Setting range	Unit	Factory setting	Effective way	Setting method	Related patterns
P09	04	Selection of Low Frequency Resonance Suppression Mode	0: Manually set the vibration frequency 1: Automatically identify the vibration frequency	-	0	Effective immediately	Run settings P
P09	05	Offline Inertial Identification Mode Selection	0: Positive and negative triangle wave mode 1: JOG mode	-	0	Effective immediately	Stop setting PST
P09	06	Maximum velocity for inertia identification	100~1000	rpm	500	Effective immediately	Stop setting PST
P09	07	Acceleration to maximum velocity time constant for inertia identification	20~800	ms	125	Effective immediately	Stop setting PST
P09	08	Waiting time after completion of single inertia identification	50~10000	ms	800	Effective immediately	Stop setting PST
P09	09	Complete single inertia identification number of motor turns	0.00~2.00	r	-	-	Display PST
P09	12	Group 1 Trap Frequency	50~4000	Hz	4000	Effective immediately	Run settings PS
P09	13	Group 1 Trap width rating	0~20	-	2	Effective immediately	Run settings PS
P09	14	Group 1 Trap depth rating	0~99	-	0	Effective immediately	Run settings PS
P09	15	Group 2 Trap Frequency	50~4000	Hz	4000	Effective immediately	Run settings PS
P09	16	Group 2 Trap width rating	0~20	-	2	Effective immediately	Run settings PS
P09	17	Group 2 Trap depth rating	0~99	-	0	Effective immediately	Run settings PS
P09	18	Group 3 Trap Frequency	50~4000	Hz	4000	Effective immediately	Run settings PS
P09	19	Group 3 Trap width rating	0~20	-	2	Effective immediately	Run settings PS
P09	20	Group 3 Trap depth rating	0~99	-	0	Effective immediately	Run settings PS
P09	21	Group 4 Trap Frequency	50~4000	Hz	4000	Effective immediately	Run settings PS
P09	22	Group 4 Trap width rating	0~20	-	2	Effective immediately	Run settings PS
P09	23	Group 4 Trap depth rating	0~99	-	0	Effective immediately	Run settings PS
P09	24	Resonance Frequency Identification Results	0~2	Hz	0	-	Display PS
P09	30	Torque disturbance compensation gain	0.0~100.0	%	0.0	Effective immediately	Run settings PS
P09	31	Time constant of torque disturbance observer filter	0.00~25.00	ms	0.50	Effective immediately	Run settings PS
P09	38	Frequency resonance frequency	1.0~100.0	Hz	100.0	Effective immediately	Run settings P
P09	39	Low Frequency Resonance Frequency Filter Setting	0~10	-	2	Effective immediately	Run settings P

P0A Group Fault and Protection Parameters

Function code	Name	Setting range	Unit	Factory setting	Effective way	Setting method	Related patterns
P0A 00	Power Input Lack Protection Selection	0: Enable fault prohibit warning 1: Enable faults and warnings 2: Prohibit faults and warnings	-	0	Effective immediately	Run settings	-
P0A 03	Power-down save feature enables selection	0: Do not perform power-down save 1: Execute power-down save	-	0	Effective immediately	Run settings	-
P0A 04	Motor overload protection gain	50~300	%	100	Effective immediately	Stop setting	-
P0A 08	Failure threshold for overspeed	0~10000	rpm	0	Effective immediately	Run settings	PST
P0A 09	Maximum position pulse frequency	100~4000	kHz	4000	Effective immediately	Stop setting	P
P0A 10	Fault threshold with excessive position deviation	1 ~1073741824	Encoder unit/command unit	3145728	Effective immediately	Run settings	P
P0A 12	Vehicle protection features enable	0: No speed protection 1: Turn on speed protection	-	1	Effective immediately	Run settings	PST
P0A 16	Determination of Low Frequency Resonance Position Deviation	1-1000	Encoder unit	5	Effective immediately	Run settings	P
P0A 17	Location setting unit selection	0: Encoder unit 1: Command unit	-	0	Effective immediately	Stop setting	P
P0A 19	DI8 Filter time constant	0~255	25ns	80	Power up again	Stop setting	-
P0A 20	DI9 Filter time constant	0~255	25ns	80	Power up again	Stop setting	-
P0A 24	Filter Time of Low Speed Pulse Input Pin	0~255	25ns	30	Power up again	Stop setting	P
P0A 25	Velocity feedback display value filter time constant	0~5000	ms	50	Effective immediately	Stop setting	-
P0A 26	Motor overload shield enables	0: Open motor overload detection 1: shielding motor overload warning and fault detection	-	0	Effective immediately	Stop setting	-
P0A 27	Velocity DO filter time constant	0~5000	ms	10	Effective immediately	Stop setting	-
P0A 28	filter time constant of orthogonal encoder	0~255	25ns	30	Power up again	Stop setting	-
P0A 30	High speed pulse input pin filter time constant	0~255	25ns	3	Power up again	Stop setting	P
P0A 32	Time window for over temperature protection	10~65535	ms	200	Effective immediately	Run settings	-
P0A 33	Overtemperature protection enables	0: Detection of Overtemperature Protection blocking of shielded motor 1: Monitoring of overtemperature protection for motor shutoff	-	1	Effective immediately	Run settings	-
P0A 36	Encoder Multiple Loop Overflow Fault Selection	No shielding	-	0	Effective immediately	Stop setting	ALL
P0A 40	Soft Limit Set	0: not soft limit 1: soft limit immediately after power on 2: soft limit after the origin is zero	1	0	Effective immediately	Stop setting	PST
P0A 41	Maximum Soft Limit	-2147483648~2147483647	Instructio	2147483	Effective	Stop	PST

Function code	Name	Setting range	Unit	Factory setting	Effective way	Setting method	Related patterns	
			n unit	647	immediately	setting		
P0A	43	Minimum Soft Limit Value	-2147483648~2147483647	Instruction unit	-2147483648	Effective immediately	Stop setting	PST
P0A	47	Lock protection test enables	0: No 1: Enable	-	1	Effective immediately	Run settings	ALL
P0A	48	Gravity Load Detection Value	0.00~300.00	%	30.0	Effective immediately	Run settings	ALL

P0B Group Monitoring parameters

Function code	Name	Setting range	Unit	Factory setting	Effective way	Setting method	Related patterns	
P0B	00	Actual motor speed	-	rpm	-	-	Display	PST
P0B	01	Speed instruction	-	rpm	-	-	Display	PS
P0B	02	Internal torque instruction (relative to rated torque)	-	%	-	-	Display	PST
P0B	03	Input signal (DI signal) monitoring	-	-	-	-	Display	PST
P0B	05	Output signal (DO signal) monitoring	-	-	-	-	Display	PST
P0B	07	Absolute position counter (32-bit decimal display)	-	Instruction Unit	-	-	Display	PST
P0B	09	Mechanical angle (number of pulses starting at origin)	-	Encoder Unit	-	-	Display	PST
P0B	10	Electrical angle	-	°	-	-	Display	PST
P0B	11	Input position instruction corresponding speed information	-	rpm	-	-	Display	P
P0B	12	Average load rate	-	%	-	-	Display	PST
P0B	13	Input instruction pulse counter (32-bit decimal display)	-	Instruction Unit	-	-	Display	P
P0B	15	Encoder position deviation counter (32-bit decimal display)	-	Encoder Unit	-	-	Display	P
P0B	17	Feedback pulse counter (32-bit decimal display)	-	Encoder Unit	-	-	Display	PST
P0B	19	Total power-up time (32-bit decimal display)	-	s	-	-	Display	PST
P0B	21	A11 Sampling voltage values	-	V	-	-	Display	PST
P0B	22	A12 Sampling voltage values	-	V	-	-	Display	PST
P0B	24	Phase current RMS	-	A	-	-	Display	PST
P0B	26	Bus voltage	-	V	-	-	Display	PST
P0B	27	Module temperature values	-	°C	-	-	Display	PST

Function code	Name	Setting range	Unit	Factory setting	Effective way	Setting method	Related patterns
P0B 33	Failure logging	0: Currentfault 1: Last 1 failure 2: Last 2 failure 9: Last 9 failures	-	0	Effective immediately	Run settings	PST
P0B 34	Number of failures selected	-	-	-	-	Display	PST
P0B 35	Selected fault timestamp	-	s	-	-	Display	PST
P0B 37	Motor speed at selected faults	-	rpm	-	-	Display	PST
P0B 38	Electrical U phase current at selected fault	-	A	-	-	Display	PST
P0B 39	Electrical V phase current at selected fault	-	A	-	-	Display	PST
P0B 40	Bus voltage at selected fault	-	V	-	-	Display	PST
P0B 41	Input terminal status at selected fault	-	-	-	-	Display	PST
P0B 42	Output terminal status at selected fault	-	-	-	-	Display	PST
P0B 53	Position Deviation Counter	-	Instruction Unit	-	-	Display	P
P0B 55	Actual motor speed(0.1rpm)	-	rpm	-	-	Display	PST
P0B 58	Mechanical absolute position (32 bits low)	-	Encoder Unit	0	-	Display	ALL
P0B 60	Mechanical absolute position (32 bits high)	-	Encoder Unit	0	-	Display	ALL
P0B 64	Real-time input position instruction counter	-	Unit of instruction	-	-	Display	PST
P0B 70	Absolute value encoder rotation circle data	-	r	0	-	Display	ALL
P0B 71	In-circle position of absolute encoder	-	Encoder Unit	0	-	Display	ALL
P0B 77	Absolute encoder absolute position (low 32 bits)	-	Encoder Unit	0	-	Display	ALL
P0B 79	Absolute encoder absolute position (high 32 bits)	-	Encoder Unit	0	-	Display	ALL
P0B 81	Rotating load single loop position (low 32 bits)	-	Encoder Unit	0	-	Display	ALL
P0B 83	Rotating load single loop position (high 32 bits)	-	Encoder Unit	0	-	Display	ALL
P0B 85	Rotating Load Single Circle Position	-	Unit of instruction	0	-	Display	ALL

P0C Group Communication parameters

Function code	Name	Setting range	Unit	Factory setting	Effective way	Setting method	Related patterns
P0C 00	ServoAxisAddress	1~247, 0 for broadcast address	-	1	Effective immediately	Run settings	PST
P0C 02	Serial Port Rate Setup	0: 2400Kbp/s 1: 4800Kbp/s 2: 9600Kbp/s 3: 19200Kbp/s 4: 38400Kbp/s 5: 57600Kbp/s	-	2	Effective immediately	Run settings	PST
P0C 03	MODBUS data format	0: no check ,2 end bits 1: parity ,1 end bit 2: check ,1 end bit 3: no check ,1 end bit	-	3	Effective immediately	Run settings	PST
P0C 08	CAN Communication rate setting	0: 20K 3: 125K 6: 1M 1: 50K 4: 250K 7: 1M 2: 100K 5: 500K	-	5	Effective immediately	Run settings	PST
P0C 09	Communication VDI	Prohibition of enabling	-	0	Effective immediately	Stop setting	PST
P0C 10	VDI default value after power on	Bit0-VDI1 default values Bit15-VDI16 default values	-	0	Power up again	Run settings	PST
P0C 11	Communication VDO	0: prohibition 1: enabling	-	0	Effective immediately	Stop setting	PST
P0C 12	Default level when VDO function is selected as 0	Bit0-VDO1 default valuesBit15-VDO16 default values	-	0	Effective immediately	Stop setting	PST
P0C 13	MODBUS communication write function code is updated to EEPROM	0: do not update EEPROM 1: update EEPROM except P0B and P0D groups	-	1	Effective immediately	Run settings	PST
P0C 14	MODBUS Error code	New agreement: 0 x0001: Illegal function (command code) 0 x0002: Illegal data address 0 x0003: Illegal data 0 x0004: Station equipment malfunction OldAgreement: x0002: command code is not x03/0x06/0x10 0 0 x0004: Servo calculates that the CRC check code received by the data frame is not equal to the data frame check code 0 x0008: Access function code does not exist 0 x0010: Write the value of the function code beyond the upper and lower limits of the function code 0 x0080: The written function code can only be modified in the servo shutdown state while the servo is currently in operation state	1	-	-	Display	-

Function code	Name	Setting range	Unit	Factory setting	Effective way	Setting method	Related patterns
P0C 16	CAN communication write function code is updated to EEPROM	0: do not update EEPROM 1: update EEPROM except P0B and P0D groups	-	0	Effective immediately	Run settings	PST
P0C 25	MODBUS Response Delay	0~5000	ms	1	Effective immediately	Run settings	PST
P0C 26	MODBUS High-level Order of Communication Data	0: higher 16, lower 16 1: lower 16, higher 16	1	1	Effective immediately	Run settings	PST
P0C 30	MODBUS Error frame format selection	0: old agreement 1: new agreement (standard agreement)	1	1	Effective immediately	Run settings	PST

P0D Group Auxiliary function parameters

Function code	Name	Setting range	Unit	Factory setting	Effective way	Setting method	Related patterns
P0D 00	Software Reset	0: No Operation 1: Enable	-	0	Effective immediately	Stop setting	-
P0D 01	Fault reset	0: No Operation 1: Enable	-	0	Effective immediately	Stop setting	-
P0D 02	Off-line Inertial Identification Function	-	-	-	Effective immediately	Run settings	-
P0D 03	Retention parameter	-	-	-	-	-	-
P0D 05	Emergency shut down	0: no operation 1: enable emergency shutdown	-	0	Effective immediately	Run settings	-
P0D 10	Automatic adjustment of analog channels	0: no operation 1: AI1 adjustments 2: AI2 adjustments	-	0	Effective immediately	Stop setting	-
P0D 11	JOG Test run function	Self-contained filtering (FFT)	-	-	-	-	-
P0D 17	DIDO Mandatory input and output enable	0: no operation 1: force DI enable, force DO not 2: force DO enable, force DI not 3: forced DIDO enables	-	0	Effective immediately	Run settings	-
P0D 18	DI Mandatory input given	0~0x01FF	-	0x01FF	Effective immediately	Run settings	-
P0D 19	DO Forced output given	0~0x001F	-	0	Effective immediately	Run settings	-
P0D 20	Absolute encoder reset enable	0: no operation 1: Reset Fault 2: reset fault and multi-loop data	-	0	Effective immediately	Stop setting	ALL
P0D 24	Gravity Load Identification	0: not identified 1: Open Identification	-	0	Effective immediately	Run settings	-

P11 Group Multi-segment position function parameter

Function code	Name	Setting range	Unit	Factory setting	Effective way	Setting method	Related patterns
P11 00	Multi-segment location operation mode	0: stop at the end of a single operation (P11-01 Select the number of segments) 1: Cyclic operation (P11-01 selects the number of segments) 2: DI switching operation (selected by DI) 3: Sequential operation (P11-01 for selection of segment number)	-	1	Effective immediately	Stop setting	P

Function code	Name	Setting range	Unit	Factory setting	Effective way	Setting method	Related patterns	
P11	01	Number of terminal segments of displacement instruction	1~16	-	1	Effective immediately	Stop setting	P
P11	02	Residual treatment	Valid in the other three modes except DI mode 0: Continue to run the unfinished segment 1: Restart operation from the first segment	-	0	Effective immediately	Stop setting	P
P11	03	Time unit	0: ms 1: s	-	0	Effective immediately	Stop setting	P
P11	04	Type of displacement instruction	0: Relative displacement command 1: Absolute displacement instruction	-	0	Effective immediately	Stop setting	P
P11	05	Sequence Run Start Select	0~16	-	0	Effective immediately	Stop setting	P
P11	12	Paragraph 1 moving displacement	-1073741824 ~ 1073741824	instruction unit	10000	Effective immediately	Run settings	P
P11	14	Maximum speed of displacement in section 1	1~6000	rpm	200	Effective immediately	Run settings	P
P11	15	Paragraph 1 displacement acceleration and deceleration time	0~65535	ms(s)	10	Effective immediately	Run settings	P
P11	16	Paragraph 1 displacement acceleration and deceleration time	0~10000	ms(s)	10	Effective immediately	Run settings	P
P11	17	Paragraph 2 moving displacement	-1073741824 ~ 1073741824	instruction unit	10000	Effective immediately	Run settings	P
P11	19	Maximum speed of displacement in section 2	1~6000	rpm	200	Effective immediately	Run settings	P
P11	20	Paragraph 2 displacement acceleration and deceleration time	0~65535	ms(s)	10	Effective immediately	Run settings	P
P11	21	Waiting time after completion of displacement in paragraph 2	0~10000	ms(s)	10	Effective immediately	Run settings	P
P11	22	Paragraph 3 moving displacement	-1073741824 ~ 1073741824	instruction unit	10000	Effective immediately	Run settings	P
P11	24	Maximum speed of displacement in section 3	1~6000	rpm	200	Effective immediately	Run settings	P
P11	25	Paragraph 3 displacement acceleration and deceleration time	0~65535	ms(s)	10	Effective immediately	Run settings	P
P11	26	Waiting time after	0~10000	ms(s)	10	Effective	Run	P

Function code	Name	Setting range	Unit	Factory setting	Effective way	Setting method	Related patterns	
	completion of displacement in paragraph 3				immediately	settings		
P11	27	Paragraph 4 moving displacement	-1073741824 ~ 1073741824	instruction unit	10000	Effective immediately	Run settings	P
P11	29	Maximum speed of displacement in section 4	1~6000	rpm	200	Effective immediately	Run settings	P
P11	30	Paragraph 4 displacement acceleration and deceleration time	0~65535	ms(s)	10	Effective immediately	Run settings	P
P11	31	Waiting time after completion of displacement in paragraph 4	0~10000	ms(s)	10	Effective immediately	Run settings	P
P11	32	Paragraph 5 moving displacement	-1073741824 ~ 1073741824	instruction unit	10000	Effective immediately	Run settings	P
P11	34	Maximum speed of displacement in section 5	1~6000	rpm	200	Effective immediately	Run settings	P
P11	35	Paragraph 5 displacement acceleration and deceleration time	0~65535	ms(s)	10	Effective immediately	Run settings	P
P11	36	Waiting time after completion of displacement in paragraph 5	0~10000	ms(s)	10	Effective immediately	Run settings	P
P11	37	Paragraph 6 moving displacement	-1073741824 ~ 1073741824	Instructions	10000	Effective immediately	Run settings	P
P11	39	Maximum speed of displacement in section 6	1~6000	rpm	200	Effective immediately	Run settings	P
P11	40	Paragraph 6 displacement acceleration and deceleration time	0~65535	ms(s)	10	Effective immediately	Run settings	P
P11	41	Waiting time after completion of displacement in paragraph 6	0~10000	ms(s)	10	Effective immediately	Run settings	P
P11	42	Paragraph 7 moving displacement	-1073741824 ~ 1073741824	instruction unit	10000	Effective immediately	Run settings	P
P11	44	Maximum speed of displacement in section 7	1~6000	rpm	200	Effective immediately	Run settings	P
P11	45	Paragraph 7 displacement acceleration and deceleration time	0~65535	ms(s)	10	Effective immediately	Run settings	P
P11	46	Waiting time after completion of displacement in paragraph 7	0~10000	ms(s)	10	Effective immediately	Run settings	P
P11	47	Paragraph 8 moving displacement	-1073741824 ~ 1073741824	Instructions	10000	Effective immediately	Run settings	P

Function code		Name	Setting range	Unit	Factory setting	Effective way	Setting method	Related patterns
P11	49	Maximum speed of displacement in section 8	1~6000	rpm	200	Effective immediately	Run settings	P
P11	50	Paragraph 8 displacement acceleration and deceleration time	0~65535	ms(s)	10	Effective immediately	Run settings	P
P11	51	Waiting time after completion of displacement in paragraph 8	0~10000	ms(s)	10	Effective immediately	Run settings	P
P11	52	Paragraph 9 moving displacement	-1073741824 ~1073741824	instruction unit	10000	Effective immediately	Run settings	P
P11	54	Maximum speed of displacement in section 9	1~6000	rpm	200	Effective immediately	Run settings	P
P11	55	Paragraph 9 displacement acceleration and deceleration time	0~65535	ms(s)	10	Effective immediately	Run settings	P
P11	56	Waiting time after completion of displacement in paragraph 9	0~10000	ms(s)	10	Effective immediately	Run settings	P
P11	57	Paragraph 10 moving displacement	-1073741824 ~1073741824	Instructions	10000	Effective immediately	Run settings	P
P11	59	Maximum speed of displacement in section 10	1~6000	rpm	200	Effective immediately	Run settings	P
P11	60	Paragraph 10 displacement acceleration and deceleration time	0~65535	ms(s)	10	Effective immediately	Run settings	P
P11	61	Waiting time after completion of displacement in paragraph 10	0~10000	ms(s)	10	Effective immediately	Run settings	P
P11	62	Paragraph 11 moving displacement	-1073741824 ~1073741824	Instructions	10000	Effective immediately	Run settings	P
P11	64	Maximum speed of displacement in section 11	1~6000	rpm	200	Effective immediately	Run settings	P
P11	65	Paragraph 11 displacement acceleration and deceleration time	0~65535	ms(s)	10	Effective immediately	Run settings	P
P11	66	Waiting time after completion of displacement in paragraph 11	0~10000	ms(s)	10	Effective immediately	Run settings	P
P11	67	Paragraph 12 moving displacement	-1073741824 ~1073741824	Instructions	10000	Effective immediately	Run settings	P
P11	69	Maximum speed of displacement in section 12	1~6000	rpm	200	Effective immediately	Run settings	P
P11	70	Paragraph 12 displacement	0~65535	ms(s)	10	Effective immediately	Run settings	P

Function code	Name	Setting range	Unit	Factory setting	Effective way	Setting method	Related patterns	
	acceleration and deceleration time							
P11	71	Waiting time after completion of displacement in paragraph 12	0~10000	ms(s)	10	Effective immediately	Run settings	P
P11	72	Paragraph 13 moving displacement	-1073741824 ~1073741824	Instructions	10000	Effective immediately	Run settings	P
P11	74	Maximum speed of displacement in section 13	1~6000	rpm	200	Effective immediately	Run settings	P
P11	75	Paragraph 13 displacement acceleration and deceleration time	0~65535	ms(s)	10	Effective immediately	Run settings	P
P11	76	Waiting time after completion of displacement in paragraph 13	0~10000	ms(s)	10	Effective immediately	Run settings	P
P11	77	Paragraph 14 moving displacement	-1073741824 ~1073741824	Instruction Unit	10000	Effective immediately	Run settings	P
P11	79	Maximum speed of displacement in section 14	1~6000	rpm	200	Effective immediately	Run settings	P
P11	80	Paragraph 14 displacement acceleration and deceleration time	0~65535	ms(s)	10	Effective immediately	Run settings	P
P11	81	Waiting time after completion of displacement in paragraph 14	0~10000	ms(s)	10	Effective immediately	Run settings	P
P11	82	Paragraph 15 moving displacement	-1073741824 ~1073741824	Instruction Unit	10000	Effective immediately	Run settings	P
P11	84	Maximum speed of displacement in section 15	1~6000	rpm	200	Effective immediately	Run settings	P
P11	85	Paragraph 15 displacement acceleration and deceleration time	0~65535	ms(s)	10	Effective immediately	Run settings	P
P11	86	Waiting time after completion of displacement in paragraph 15	0~10000	ms(s)	10	Effective immediately	Run settings	P
P11	87	Paragraph 16 moving displacement	-1073741824 ~1073741824	Instruction Unit	10000	Effective immediately	Run settings	P
P11	89	Maximum speed of displacement in section 16	1~6000	rpm	200	Effective immediately	Run settings	P
P11	90	Paragraph 16 displacement acceleration and deceleration time	0~65535	ms(s)	10	Effective immediately	Run settings	P

Function code	Name	Setting range	Unit	Factory setting	Effective way	Setting method	Related patterns
P11 91	Waiting time after completion of displacement in paragraph 16	0~10000	ms(s)	10	Effective immediately	Run settings	P

P12 Group Multi-segment speed parameter

Function code	Name	Setting range	Unit	Factory setting	Effective way	Setting method	Related patterns
P12 00	Multi-segment speed instruction running mode	0: stop at the end of a single operation (P12-01 Select the number of segments) 1: Cyclic operation (P12-01 selects the number of segments) 2: Switch through external DI	-	1	Effective immediately	Stop setting	S
P12 01	Selection of terminal segments of speed instruction	1~16	-	16	Effective immediately	Stop setting	S
P12 02	Runtime unit selection	0-sec 1-min	-	0	Effective immediately	Stop setting	S
P12 03	Acceleration time 1	0~65535	ms	10	Effective immediately	Stop setting	S
P12 04	Deceleration time 1	0~65535	ms	10	Effective immediately	Stop setting	S
P12 05	Acceleration time 2	0~65535	ms	50	Effective immediately	Stop setting	S
P12 06	Deceleration time 2	0~65535	ms	50	Effective immediately	Stop setting	S
P12 07	Acceleration time 3	0~65535	ms	100	Effective immediately	Stop setting	S
P12 08	Deceleration time3	0~65535	ms	100	Effective immediately	Stop setting	S
P12 09	Acceleration time 4	0~65535	ms	150	Effective immediately	Stop setting	S
P12 10	Deceleration time 4	0~65535	ms	150	Effective immediately	Stop setting	S
P12 20	Paragraph 1 Speed Directive	-6000~6000	rpm	0	Effective immediately	Stop setting	S
P12 21	Paragraph 1 instruction run time	0~6553.5	S (min)	5.0	Effective immediately	Stop setting	S
P12 22	Paragraph 1 Acceleration and deceleration	0: Zero acceleration and deceleration time 1: Acceleration and deceleration time 1 2: Acceleration and deceleration time 2 3: Acceleration and deceleration time 3 4: Acceleration and deceleration time 4	-	0	Effective immediately	Stop setting	S
P12 23	Paragraph 2 Speed Directive	-6000~6000	rpm	100	Effective immediately	Stop setting	S
P12 24	Paragraph 2 instruction run time	0~6553.5	S (min)	5.0	Effective immediately	Stop setting	S
P12 25	Paragraph 2 Acceleration and deceleration	0: Zero acceleration and deceleration time 1: Acceleration and deceleration time 1 2: Acceleration and deceleration time 2 3: Acceleration and deceleration time 3 4: Acceleration and deceleration time 4	-	0	Effective immediately	Stop setting	S
P12 26	Paragraph 3 Speed	-6000~6000	rpm	300	Effective	Stop	S

Function code	Name	Setting range	Unit	Factory setting	Effective way	Setting method	Related patterns	
	Directive				immediately	setting		
P12	27	Paragraph 3 instruction run time	0~6553.5	S (min)	5.0	Effective immediately	Stop setting	S
P12	28	Paragraph 3 Acceleration and deceleration	0: Zero acceleration and deceleration time 1: Acceleration and deceleration time 2: Acceleration and deceleration time 3: Acceleration and deceleration time 4: Acceleration and deceleration time	-	0	Effective immediately	Stop setting	S
P12	29	Paragraph 4 Speed Directive	-6000~6000	rpm	500	Effective immediately	Stop setting	S
P12	30	Paragraph 4 instruction run time	0~6553.5	S (min)	5.0	Effective immediately	Stop setting	S
P12	31	Paragraph 4 Acceleration and deceleration	0: Zero acceleration and deceleration time 1: Acceleration and deceleration time 2: Acceleration and deceleration time 3: Acceleration and deceleration time 4: Acceleration and deceleration time	-	0	Effective immediately	Stop setting	S
P12	32	Paragraph 5 Speed Directive	-6000~6000	rpm	700	Effective immediately	Stop setting	S
P12	33	Paragraph 5 instruction run time	0~6553.5	S (min)	5.0	Effective immediately	Stop setting	S
P12	34	Paragraph 5 Acceleration and deceleration	0: Zero acceleration and deceleration time 1: Acceleration and deceleration time 2: Acceleration and deceleration time 3: Acceleration and deceleration time 4: Acceleration and deceleration time	-	0	Effective immediately	Stop setting	S
P12	35	Paragraph 6 Speed Directive	-6000~6000	rpm	900	Effective immediately	Stop setting	S
P12	36	Paragraph 6 instruction run time	0~6553.5	S (min)	5.0	Effective immediately	Stop setting	S
P12	37	Paragraph 6 Acceleration and deceleration	0: Zero acceleration and deceleration time 1: Acceleration and deceleration time 2: Acceleration and deceleration time 3: Acceleration and deceleration time 4: Acceleration and deceleration time	-	0	Effective immediately	Stop setting	S
P12	38	Paragraph 7 Speed Directive	-6000~6000	rpm	600	Effective immediately	Stop setting	S
P12	39	Paragraph 7 instruction run time	0~6553.5	S (min)	5.0	Effective immediately	Stop setting	S
P12	40	Paragraph 7 Acceleration and deceleration	0: Zero acceleration and deceleration time 1: Acceleration and deceleration time 2: Acceleration and deceleration time 3: Acceleration and deceleration time 4: Acceleration and deceleration time	-	0	Effective immediately	Stop setting	S
P12	41	Paragraph 8 Speed Directive	-6000~6000	rpm	300	Effective immediately	Stop setting	S
P12	42	Paragraph 8 instruction run time	0~6553.5	S (min)	5.0	Effective immediately	Stop setting	S
P12	43	Paragraph 8 Acceleration and deceleration	0: Zero acceleration and deceleration time 1: Acceleration and deceleration time 2: Acceleration and deceleration time 3: Acceleration and deceleration time 4: Acceleration and deceleration time	-	0	Effective immediately	Stop setting	S

Function code		Name	Setting range	Unit	Factory setting	Effective way	Setting method	Related patterns
P12	44	Paragraph 9 Speed Directive	-6000~6000	rpm	100	Effective immediately	Stop setting	S
P12	45	Paragraph 9 instruction run time	0~6553.5	S (min)	5.0	Effective immediately	Stop setting	S
P12	46	Paragraph 9 Acceleration and deceleration	0: Zero acceleration and deceleration time 1: Acceleration and deceleration time 2: Acceleration and deceleration time 3: Acceleration and deceleration time 4: Acceleration and deceleration time	-	0	Effective immediately	Stop setting	S
P12	47	Paragraph 10 Speed Directive	-6000~6000	rpm	-100	Effective immediately	Stop setting	S
P12	48	Paragraph 10 instruction run time	0~6553.5	S (min)	5.0	Effective immediately	Stop setting	S
P12	49	Paragraph 10 Acceleration and deceleration	0: Zero acceleration and deceleration time 1: Acceleration and deceleration time 2: Acceleration and deceleration time 3: Acceleration and deceleration time 4: Acceleration and deceleration time	-	0	Effective immediately	Stop setting	S
P12	50	Paragraph 11 Speed Directive	-6000~6000	rpm	-300	Effective immediately	Stop setting	S
P12	51	Paragraph 11 instruction run time	0~6553.5	S (min)	5.0	Effective immediately	Stop setting	S
P12	52	Paragraph 11 Acceleration and deceleration	0: Zero acceleration and deceleration time 1: Acceleration and deceleration time 2: Acceleration and deceleration time 3: Acceleration and deceleration time 4: Acceleration and deceleration time	-	0	Effective immediately	Stop setting	S
P12	53	Paragraph 12 Speed Directive	-6000~6000	rpm	-500	Effective immediately	Stop setting	S
P12	54	Paragraph 12 instruction run time	0~6553.5	S (min)	5.0	Effective immediately	Stop setting	S
P12	55	Paragraph 12 Acceleration and deceleration	0: Zero acceleration and deceleration time 1: Acceleration and deceleration time 2: Acceleration and deceleration time 3: Acceleration and deceleration time 4: Acceleration and deceleration time	-	0	Effective immediately	Stop setting	S
P12	56	Paragraph 13 Speed Directive	-6000~6000	rpm	-700	Effective immediately	Stop setting	S
P12	57	Paragraph 13 instruction run time	0~6553.5	S (min)	5.0	Effective immediately	Stop setting	S
P12	58	Paragraph 13 Acceleration and deceleration	0: Zero acceleration and deceleration time 1: Acceleration and deceleration time 2: Acceleration and deceleration time 3: Acceleration and deceleration time 4: Acceleration and deceleration time	-	0	Effective immediately	Stop setting	S
P12	59	Paragraph 14 Speed Directive	-6000~6000	rpm	-900	Effective immediately	Stop setting	S
P12	60	Paragraph 14 instruction		S (min)	5.0	Effective immediately	Stop setting	S
P12	61	Paragraph 14 Acceleration and deceleration	0: Zero acceleration and deceleration time 1: Acceleration and deceleration time 2: Acceleration and deceleration time 3: Acceleration and deceleration time	-	0	Effective immediately	Stop setting	S

Function code	Name	Setting range	Unit	Factory setting	Effective way	Setting method	Related patterns
		4: Acceleration and deceleration time 4					
P12 62	Paragraph 15 Speed Directive	-6000~6000	rpm	-600	Effective immediately	Stop setting	S
P12 63	Paragraph 15 instruction run time	0~6553.5	S (min)	5.0	Effective immediately	Stop setting	S
P12 64	Paragraph 15 Acceleration and deceleration	0: Zero acceleration and deceleration time 1: Acceleration and deceleration time 1 2: Acceleration and deceleration time 2 3: Acceleration and deceleration time 3 4: Acceleration and deceleration time 4	-	0	Effective immediately	Stop setting	S
P12 65	Paragraph 16 Speed Directive	-6000~6000	rpm	-300	Effective immediately	Stop setting	S
P12 66	Paragraph 16 instruction run time	0~6553.5	S (min)	5.0	Effective immediately	Stop setting	S
P12 67	Paragraph 16. Acceleration and deceleration	0: Zero acceleration and deceleration time 1: Acceleration and deceleration time 1 2: Acceleration and deceleration time 2 3: Acceleration and deceleration time 3 4: Acceleration and deceleration time 4	-	0	Effective immediately	Stop setting	S

P17 Group Virtual DIDO parameters

Function code	Name	Setting range	Unit	Factory setting	Effective way	Setting method	Related patterns
P17 00	VDI1 Terminal function selection	0~37	-	0	Outage takes effect	Run settings	-
P17 01	VDI1 Terminal logic selection	0: indicates VDI1 write 1 is valid 1: indicates that VDI1 write value changes from 0 to 1	-	0	Outage takes effect	Run settings	-
P17 02	VDI2 Terminal function selection	0~37	-	0	Outage takes effect	Run settings	-
P17 03	VDI2 Terminal logic selection	0: indicates VDI2 write 1 is valid 1: indicates that VDI2 write value changes from 0 to 1	-	0	Outage takes effect	Run settings	-
P17 04	VDI3 Terminal function selection	0~37	-	0	Outage takes effect	Run settings	-
P17 05	VDI3 Terminal logic selection	0: indicates VDI3 write 1 is valid 1: indicates that VDI3 write value changes from 0 to 1	-	0	Outage takes effect	Run settings	-
P17 06	VDI4 Terminal function selection	0~37	-	0	Outage takes effect	Run settings	-
P17 07	VDI4 Terminal logic selection	0: indicates VDI4 write 1 is valid 1: indicates that VDI4 write value changes from 0 to 1	-	0	Outage takes effect	Run settings	-
P17 08	VDI5 Terminal function selection	0~37	-	0	Outage takes effect	Run settings	-
P17 09	VDI5 Terminal logic selection	0: indicates VDI5 write 1 is valid 1: indicates that VDI5 write value changes from 0 to 1	-	0	Outage takes effect	Run settings	-
P17 10	VDI6 Terminal function selection	0~37	-	0	Outage takes effect	Run settings	-
P17 11	VDI6 Terminal logic selection	0: indicates VDI6 write 1 is valid 1: indicates that VDI6 write value changes from 0 to 1	-	0	Outage takes effect	Run settings	-
P17 12	VDI7 Terminal	0~37	-	0	Outage	Run	-

Function code	Name	Setting range	Unit	Factory setting	Effective way	Setting method	Related patterns
	function selection				takes effect	settings	
P17	13 VDI7 Terminal logic selection	0: indicates VDI7 write 1 is valid 1: indicates that VDI7 write value changes from 0 to 1	-	0	Outage takes effect	Run settings	-
P17	14 VDI8 Terminal function selection	0~37	-	0	Outage takes effect	Run settings	-
P17	15 VDI8 Terminal logic selection	0: indicates VDI8 write 1 is valid 1: indicates that VDI8 write value changes from 0 to 1	-	0	Outage takes effect	Run settings	-
P17	16 VDI9 Terminal function selection	0~37	-	0	Outage takes effect	Run settings	-
P17	17 VDI9 Terminal logic selection	0: indicates VDI9 write 1 is valid 1: indicates that VDI9 write value changes from 0 to 1	-	0	Outage takes effect	Run settings	-
P17	18 VDI10 Terminal function selection	0~37	-	0	Outage takes effect	Run settings	-
P17	19 VDI10 Terminal logic selection	0: indicates VDI10 write 1 is valid 1: indicates that VDI10 write value changes from 0 to 1	-	0	Outage takes effect	Run settings	-
P17	20 VDI11 Terminal function selection	0~37	-	0	Outage takes effect	Run settings	-
P17	21 VDI11 Terminal logic selection	0: indicates VDI11 write 1 is valid 1: indicates that VDI11 write value changes from 0 to 1	-	0	Outage takes effect	Run settings	-
P17	22 VDI12 Terminal function selection	0~37	-	0	Outage takes effect	Run settings	-
P17	23 VDI12 Terminal logic selection	0: indicates VDI12 write 1 is valid 1: indicates that VDI12 write value changes from 0 to 1	-	0	Outage takes effect	Run settings	-
P17	24 VDI13 Terminal function selection	0~37	-	0	Outage takes effect	Run settings	-
P17	25 VDI13 Terminal logic selection	0: indicates VDI13 write 1 is valid 1: indicates that VDI13 write value changes from 0 to 1	-	0	Outage takes effect	Run settings	-
P17	26 VDI14 Terminal function selection	0~37	-	0	Outage takes effect	Run settings	-
P17	27 VDI14 Terminal logic selection	0: indicates VDI14 write 1 is valid 1: indicates that VDI14 write value changes from 0 to 1	-	0	Outage takes effect	Run settings	-
P17	28 VDI15 Terminal function selection	0~37	-	0	Outage takes effect	Run settings	-
P17	29 VDI15 Terminal logic selection	0: indicates VDI14 write 1 is valid 1: indicates that VDI14 write value changes from 0 to 1	-	0	Outage takes effect	Run settings	-
P17	30 VDI16 Terminal function selection	0~37	-	0	Outage takes effect	Run settings	-
P17	31 VDI16 Terminal logic selection	0: indicates VDI16 write 1 is valid 1: indicates that VDI16 write value changes from 0 to 1	-	0	Outage takes effect	Run settings	-
P17	32 VDO Virtual level	-	-	-	-	Display	-
P17	33 VDO1 Terminal function selection	0~22	-	0	Outage takes effect	Run settings	-
P17	34 VDO1 Terminal logic selection	0: means valid output 1 1: means valid output 0	-	0	Outage takes effect	Run settings	-

Function code	Name	Setting range	Unit	Factory setting	Effective way	Setting method	Related patterns
P17 34	VDO1 Terminal logic selection	0~22	-	0	Outage takes effect	Run settings	-
P17 36	VDO2 Terminal logic selection	0: means valid output 1 1: means valid output 0	-	0	Outage takes effect	Run settings	-
P17 37	VDO3 Terminal logic selection	0~22	-	0	Outage takes effect	Run settings	-
P17 38	VDO3 Terminal logic selection	0: means valid output 1 1: means valid output 0	-	0	Outage takes effect	Run settings	-
P17 39	VDO4 Terminal function selection	0~22	-	0	Outage takes effect	Run settings	-
P17 40	VDO4 Terminal logic selection	0: means valid output 1 1: means valid output 0	-	0	Outage takes effect	Run settings	-
P17 41	VDO5 Terminal function selection	0~22	-	0	Outage takes effect	Run settings	-
P17 42	VDO5 Terminal logic selection	0: means valid output 1 1: means valid output 0	-	0	Outage takes effect	Run settings	-
P17 43	VDO6 Terminal function selection	0~22	-	0	Outage takes effect	Run settings	-
P17 44	VDO6 Terminal logic selection	0: means valid output 1 1: means valid output 0	-	0	Outage takes effect	Run settings	-
P17 45	VDO7 Terminal function selection	0~22	-	0	Outage takes effect	Run settings	-
P17 46	VDO7 Terminal logic selection	0: means valid output 1 1: means valid output 0	-	0	Outage takes effect	Run settings	-
P17 47	VDO8 Terminal function selection	0~22	-	0	Outage takes effect	Run settings	-
P17 48	VDO8 Terminal logic selection	0: means valid output 1 1: means valid output 0	-	0	Outage takes effect	Run settings	-
P17 49	VDO9 Terminal function selection	0~22	-	0	Outage takes effect	Run settings	-
P17 50	VDO9 Terminal logic selection	0: means valid output 1 1: means valid output 0	-	0	Outage takes effect	Run settings	-
P17 51	VDO10 Terminal function selection	0~22	-	0	Outage takes effect	Run settings	-
P17 52	VDO10 Terminal logic selection	0: means valid output 1 1: means valid output 0	-	0	Outage takes effect	Run settings	-
P17 53	VDO11 Terminal function selection	0~22	-	0	Outage takes effect	Run settings	-
P17 54	VDO11 Terminal logic selection	0: means valid output 1 1: means valid output 0	-	0	Outage takes effect	Run settings	-
P17 55	VDO12 Terminal function selection	0~22	-	0	Outage takes effect	Run settings	-
P17 56	VDO12 Terminal logic selection	0: means valid output 1 1: means valid output 0	-	0	Outage takes effect	Run settings	-
P17 57	VDO13 Terminal function selection	0~22	-	0	Outage takes effect	Run settings	-
P17 58	VDO13 Terminal logic selection	0: means valid output 1 1: means valid output 0	-	0	Outage takes effect	Run settings	-
P17 59	VDO14 Terminal function selection	0~22	-	0	Outage takes effect	Run settings	-
P17 60	VDO14 Terminal logic selection	0: means valid output 1 1: means valid output 0	-	0	Outage takes effect	Run settings	-

Function code	Name	Setting range	Unit	Factory setting	Effective way	Setting method	Related patterns
P17 61	VDO15 Terminal function selection	0~22	-	0	Outage takes effect	Run settings	-
P17 62	VDO15 Terminal logic selection	0: means valid output 1 1: means valid output 0	-	0	Outage takes effect	Run settings	-
P17 63	VDO16 Terminal function selection	0~22	-	0	Outage takes effect	Run settings	-
P17 64	VDO16 Terminal logic selection	0: means valid output 1 1: means valid output 0	-	0	Outage takes effect	Run settings	-

P30 Group Communication read servo-related variables Panel invisible

Function code	Name	Setting range	Unit	Factory setting	Effective way	Setting method	Related patterns
P30 00	Communications read servo state	-	-	-	-	Communication read only	PST
P30 01	Communication Read DO Function Status 1	-	-	-	-	Communication read only	PST
P30 02	Communication Read DO Function 2	-	-	-	-	Communication read only	PST
P30 03	Communication read input pulse instruction sampling	-	-	-	-	Display	PST

P31 Group Communication gives servo-related variables Panel invisible

Function code	Name	Setting range	Unit	Factory setting	Effective way	Setting method	Related patterns
P31 00	Communication given VDI virtual level	0~65535	-	0	Effective immediately	Run settings	PST
P31 04	Communication given DO output state	0~31	-	0	Effective immediately	Run settings	PST
P31 09	Communication Given Speed Command	-6000.000~6000.000	rpm	0	Effective immediately	Run settings	S
P31 11	Communication given torque instruction	-100.000~100.000	%	0	Effective immediately	Run settings	T

DIDO Function definition

Code	Name	Function	Description	Notes
Enter the signal function instructions				
FunIN.1	S-ON	Servo Enable	Invalid -Servo motor disable; Effective -Servo motor power on.	The logical selection of the corresponding terminal must be set to: level valid. When the corresponding DI or VDI terminal of this function changes , or when the logic selection of the corresponding terminal changes, the change needs to be electrified again before the change takes effect.
FunIN.2	ALM-RST	Failure and warning reset (along effective function)	Invalid -Servo motor disable; Effective -Servo motor power on.	The logical selection of the corresponding terminal must be set to: edge valid. If the selection level is valid , the drive internal force is set to edge valid. According to the alarm type, some alarm reset servo can continue to work.

Code	Name	Function	Description	Notes
FunIN.3	GAIN-SEL	Gain switching	When P08-08=0 : Invalid-speed control loop for PI control; Effective-speed control ring for P control. When P08-08=1, press the P08-09 settings.	The logic selection of the corresponding terminal is recommended to be set to: level effective.
FunIN.4	CMD-SEL	Switching of Main and Auxiliary Operation Instruction	Invalid - the current running instruction is A; Valid -the current running instruction is B	The logic selection of the corresponding terminal is recommended to be set to: level effective.
FunIN.5	DIR-SEL	Multi-segment speed DI switching operation direction setting	Invalid -default instruction direction; Valid -instruction in reverse direction.	The logic selection of the corresponding terminal is recommended to be set to: level effective.
FunIN.6	CMD1	Multi-segment running instruction switch 1	16 instruction selection	The logic selection of the corresponding terminal is recommended to be set to: level effective.
FunIN.7	CMD2	Multi-segment operation instruction switch 2	16 instruction selection	The logic selection of the corresponding terminal is recommended to be set to: level effective.
FunIN.8	CMD3	Multi-segment running instruction switch 3	16 instruction selection	The logic selection of the corresponding terminal is recommended to be set to: level effective.
FunIN.9	CMD4	Multi-segment operation instruction switching 4	16 instruction selection	The logic selection of the corresponding terminal is recommended to be set to: level effective.
FunIN.10	M1-SEL	Mode switching 1	According to the selected control mode (3,4,5), switch between speed, position, torque	The logic selection of the corresponding terminal is recommended to be set to: level effective.
FunIN.11	M2-SEL	Mode switching 2	According to the selected control mode (6), switch between speed, position, torque.	The logic selection of the corresponding terminal is recommended to be set to: level effective.
FunIN.12	ZCLAMP	Zero-position fixed enable	Effective -enable zero-bit fixed function; Invalid-No zero-bit fixing function.	The logic selection of the corresponding terminal is recommended to be set to: level effective.
FunIN.13	INHIBIT	Position Directive Prohibition	Effective -enable zero-bit fixed function; Invalid-No zero-bit fixing function.	Originally for pulse prohibition function. Now upgrade to position instruction prohibition, including internal and external position instructions. The logical selection of the corresponding terminal must be set to: level valid.
FunIN.14	P-OT	Forward Overpass Switch	Effective -No positive drive; Invalid -Allows forward drive.	When the mechanical motion exceeds the movable range, enter the overrun prevention function: the logic selection of the corresponding terminal, it is recommended to set to: level effective.

Code	Name	Function	Description	Notes
FunIN.15	N-OT	Reverse Overpass Switch	When the mechanical movement exceeds the movable range, enter the over-range prevention function: Effective -No reverse drive; Invalid -allows reverse drive.	The logic selection of the corresponding terminal is recommended to be set to: level effective.
FunIN.16	P-CL	Positive external torque limit	According to the choice of P07-07, the torque limit source is switched. P07-07=1: Effective -Positive external torque limit is effective; Invalid -positive internal torque limit valid. P07-07=3 and AI the limit value is greater than the positive external limit value: Effective -Positive external torque limit is effective; Invalid -AI torque limit valid. P07-07=4: Effective -AI torque limit effective; Invalid -positive internal torque limit valid.	The logic selection of the corresponding terminal is recommended to be set to: level effective.
FunIN.17	N-CL	Negative External Torque Limit	According to the choice of P07-07, the torque limit source is switched. P07-07=1: Effective-reversal external torque limit effective; Invalid-reversal internal torque limit valid. P07-07=3 and AI the limit value is less than the reverse external limit value: Effective -Reverse external torque limit valid. Invalid -AI torque limit valid. At P07-07=4: Effective -AI torque limit effective; Invalid-reversal internal torque limit valid.	The logic selection of the corresponding terminal is recommended to be set to: level effective.
FunIN.18	JOGCMD+	Forward Point Movement	Valid -enter according to a given instruction; Invalid -Run instruction stop input.	The logic selection of the corresponding terminal is recommended to be set to: level effective.
FunIN.19	JOGCMD-	Negative orientation point	Valid -reverse input according to a given instruction; Invalid -Run instruction stop input.	The logic selection of the corresponding terminal is recommended to be set to: level effective.
FunIN.20	POSSTEP	Step enable	Effective-executes the instruction step quantity instruction; Invalid -the instruction is zero and is located.	The logic selection of the corresponding terminal is recommended to be set to: level effective.
FunIN.21	HX1	Handwheel power signal1	HX1 valid, HX2 invalid: X10 HX1 invalid, HX2 valid: X100 Additional: X1	The logic selection of the corresponding terminal is recommended to be set to: level effective.
FunIN.22	HX2	Handwheel power signal2		

Code	Name	Function	Description	Notes
FunIN.23	HX_EN	Handwheel enable signal	Invalid -Position control according to P05-00 function code selection; Effective-receive handwheel pulse signal in position mode for position control.	The logic selection of the corresponding terminal is recommended to be set to: level effective.
FunIN.24	GEAR_SEL	Electronic gear selection	Invalid -electronic gear ratio 1; Effective -electronic gear ratio 2.	The logic selection of the corresponding terminal is recommended to be set to: level effective.
FunIN.25	TOQDirSel	Torque Instruction Direction Setting	Invalid -positive direction; Valid -in the opposite direction.	The logic selection of the corresponding terminal is recommended to be set to: level effective.
FunIN.26	SPDDirSel	Speed Instruction Direction Setting	Invalid -positive direction; Valid -in the opposite direction.	The logic selection of the corresponding terminal is recommended to be set to: level effective.
FunIN.27	POSDirSel	Position Instruction Direction Setting	Invalid -positive direction; valid -in the opposite direction.	The logic selection of the corresponding terminal is recommended to be set to: level effective.
FunIN.28	PosInSen	Multi-segment position instruction enables	Effective Invalid -ignores internal multi-segment instructions; valid -start internal multiple segments.	The logic selection of the corresponding terminal is recommended to be set to: level effective.
FunIN.29	XintFree	Discontinuation of interrupt duration	Invalidity -prohibition; Effective -enabling.	The logic selection of the corresponding terminal is recommended to be set to: edge valid.
FunIN.31	HomeSwitch	Origin switch	Invalid -not triggered; Effective -trigger.	The logic selection of the corresponding terminal is recommended to be set to: edge valid. The DI function is recommended to be configured to DI8 or DI9 terminals.
FunIN.32	HomingStart	Origin Recovery Enable	Invalidity -prohibition; Effective -enabling.	The logic selection of the corresponding terminal is recommended to be set to: edge valid.
FunIN.33	XintInhibit	Interrupt length prohibition	Effective -prohibition of interruption; Invalid -Allow interrupt fixed length.	The logical selection of the corresponding terminal must be set to: level valid. If set to 2(rising edge valid) drive internal will be forced to change to 1(high level effective); If set to 3(descend edge valid), drive internal force is changed to 0(low level valid); if set to 4(rise edge, descent edge are valid), drive internal force is changed to 0(low level valid)
FunIN.34	Emergency Stop	emergency shut down	Effective-zero speed after shutdown position lock; Invalid-when running state has no effect	The logic selection of the corresponding terminal is recommended to be set to: level effective.
FunIN.35	ClrPosErr	Clear position deviation	Effective-zero position deviation; Invalid-position deviation is not clear.	The logic selection of the corresponding terminal is recommended to be set to: edge valid. The DI function is recommended to be configured to DI8 or DI9 terminals.

Code	Name	Function	Description	Notes
FunIN.36	V_LmtSel	Internal speed limit source	valid -P07-19 as internal positive and negative velocity limits (P07-17=2); Invalid -P07-20 as internal positive and negative speed limit (P07-17=2).	The logic selection of the corresponding terminal is recommended to be set to: level effective.
FunIN.37	PulseInhibit	Pulse instruction forbidden	During position control mode, when the position instruction source is pulse instruction (P05-00=0): Invalid -respondable impulse instruction; valid -does not respond to impulse instructions.	The logic selection of the corresponding terminal is recommended to be set to: level effective.
Output Signal Function Description				
FunOUT.1	S-RDY	Servo ready	Servo ready to receive S-ON valid signal: Effective -Servo ready; Invalid -Servo not ready.	-
FunOUT.2	TGON	Motor rotary output	If the speed of the servo motor is higher than the speed threshold: Effective -motor rotation signal is effective; Invalid -motor rotation signal invalid.	-
FunOUT.3	ZERO	Zero-speed	Output signal when servo motor stops turning: The effective motor speed is zero; Invalid motor speed is not zero.	-
FunOUT.4	V-CMP	Speed consistency	During speed control, the absolute value of the difference between speed and speed instruction of servo motor is less than that of P06-17 speed deviation setting value.	-
FunOUT.5	COIN	Location completed	During position control, the position deviation pulse is effective when it reaches the P05-21 range of positioning completion.	-
FunOUT.6	NEAR	Location close	During position control, the position deviation pulse is effective when it reaches the positioning signal amplitude P05-22 set value.	-
FunOUT.7	C-LT	Torque limitation	Torque limit confirmation signal: Effective -motor torque limitation; Invalid -Motor torque is not limited.	-
FunOUT.8	V-LT	Speed limit	Confirmation signal of speed limitation in torque control: Effective -motor speed limit; Invalid-motor speed is not limited.	-
FunOUT.9	BK	Lock output	Lock signal output: Effective -close, release lock; Invalid -start lock.	-
FunOUT.10	WARN	Warning output	Warning output signal is valid. (conduction)	-
FunOUT.11	ALM	Fault output	The state is valid when the fault is detected.	-

Code	Name	Function	Description	Notes
FunOUT.12	ALMO1	Output 3 alarm codes	Output 3 bit alarm code.	-
FunOUT.13	ALMO2	Output 3 alarm codes	Output 3 bit alarm code.	-
FunOUT.14	ALMO3	Output 3 alarm codes	Output 3 bit alarm code.	-
FunOUT.15	Xintcoin	Interrupt length completed	Effective -interrupt fixed length positioning completed; Invalid-interrupt fixed length positioning is not complete.	-
FunOUT.16	HomeAttain	Origin zero output	Zero state of origin: Effective -zero origin; Invalid -the origin does not return to zero.	-
FunOUT.17	ElecHome Attain	Electrical zero output	Electrical return status: Effective -electrical origin back to zero; Invalid -the electrical origin does not return to zero.	-
FunOUT.18	ToqReach	Torque reaches output	Effective -the absolute value of torque reaches the set value; Invalid -the absolute value of torque is less than the set value.	-
FunOUT.19	V-Arr	Speedto output	Effective-speed feedback to the set value; Invalid-speed feedback does not reach the set value.	-
FunOUT.20	AnglntRdy	Angle Identification Output	Effective -complete angle identification; Invalid -Incomplete angle identification.	-
FunOUT.21	DB	DB Brake output	Effective -dynamic brake relay disconnected; Invalid-dynamic brake relay suction.	-
FunOUT.22	CmdOk	Internal instruction output	Effective -Internal instruction completed; Invalid -Internal instruction not completed.	-

Chapter 6 MODBUS communication protocols

The function code of the servo drive is divided into 16 bits and 32 bits, according to the data length. The function code can be read and written through the MODBUS RTU protocol. When writing the function code data, the command code is different according to the data length.

Operation	Command code
Read 16/32 bit function code	0x03
Write 16-bit function code	0x06
Write 32-bit function code	0x10

1) Read function code: 0x03

In the MODBUS RTU protocol, the command code: 0x03 is used to read 16-bit and 32-bit function codes.
Request frame format:

START	Greater than or equal to 3.5 characters of idle time, indicating the start of a frame Servo axis address 1~247.
ADDR	Servo axis address 1~247。 ◆ Notes: Here 1~247 are decimal numbers, which are converted to hexadecimal numbers when filling in ADDR.
CMD	command code: 0x03
DATA[0]	Start function code group number, such as function code P06-11, 06 is the group number. ◆ Note: Here 06 is a hexadecimal number, no hex conversion is required when filling in DATA[0]
DATA[1]	The offset within the initial function code group, such as function code P06-11, 11 is the offset. Note: Here 11 is a decimal number, it should be converted to hexadecimal 0x0B when filling in DATA [1]
DATA[2]	Number of read function codes (upper 8 digits), hexadecimal
DATA[3]	Number of read function codes (lower 8 digits), hexadecimal
CRCL	CRC check valid byte (lower 8 bits)
CRCH	CRC check valid byte (higher8 bits)
END	Greater than or equal to 3.5 characters of idle time, end of one frame

Response frame format:

START	Greater than or equal to 3.5 characters of idle time, indicating the start of a frame	DATA[...]	-
ADDR	Servo axis address, hex	DATA[N*2-1]	Last function code value, lower 8 bits
CMD	Command function, 0x03	CRCL	CRC check low significant byte
DATALENGTH	The number of function code bytes, equal to the number of read function codes N*2	CRCH	CRC check high significant byte
DATA[0]	Start function code value, high 8 bits	END	Greater than or equal to 3.5 characters of idle time, end of one frame
DATA[1]	Start function code value, low8 bits		

In the MODBUS RTU protocol, the command code: 0x06 is used to write the 16-bit function code; the command code: 0x10 is used to write the 32-bit function code.

2) Write 16-bit function code (0x06)

It is forbidden to use 0x06 to write the 32-bit function code, otherwise unpredictable errors will occur!

Request frame format:

START	Greater than or equal to 3.5 characters of idle time, indicating the start of a frame
ADDR	Servo axis address 1~247. Note: Here 1~247 are decimal numbers, which will be converted to hexadecimal numbers when filling in ADDR.
CMD	Command code, 0x06
DATA[0]	The group number of the written function code, such as writing function code P06-11, 06 is the group number. Note: Here 06 is a hexadecimal number, no hex conversion is required when filling in DATA[0]
DATA[1]	The written function code offset, such as writing function code P06-11, 11 is the offset. Note: Here 11 is a decimal number, it should be converted to hexadecimal 0x0B when filling in DATA[1]
DATA[2]	Write data high byte, hex
DATA[3]	Write data low byte, hex
CRCL	CRC check low significant byte
CRCH	CRC check high significant byte
END	Greater than or equal to 3.5 characters of idle time, end of one frame

response frame format:

START	Greater than or equal to 3.5 characters of idle time, indicating the start of a frame	DATA[2]	Write data high byte, hex
ADDR	Servo axis address, hexadecimal data.	DATA[3]	Write data low byte, hex
CMD	Command code, 0x06	CRCL	CRC check low significant byte
DATA[0]	The group number of the written function code, such as writing function code P06-11, it is 0x06	CRCH	CRC check high significant byte
DATA[1]	The written function code offset, such as writing function code P06-11, it is 0x0B	END	Greater than or equal to 3.5 characters of idle time, end of one frame

3) Write 32-bit function code (0x10)

It is forbidden to use 0x10 to write the 16-bit function code, otherwise unpredictable errors will occur! Request frame format:

START	Greater than or equal to 3.5 characters of idle time, indicating the start of a frame
ADDR	Servo axis address 1~247. Note: Here 1~247 are decimal numbers, which will be converted to hexadecimal numbers when filling in ADDR.
CMD	Command code, 0x10
DATA[0]	The first function code group number to be written, such as writing function code P11-12, 11 is the function code group Note: Here 11 is a hexadecimal number, no hex conversion is required when filling in DATA[0]
DATA[1]	The offset within the group is written as the starting function code. For example, when writing function code P11-12, 12 is the offset within the group. Note: Here 12 is a decimal number, which is converted to hexadecimal 0x0C when filling in DATA[1]
DATA[2]	The number of function codes is high 8 bits M(H), and the length of 32 bits function code is 2
DATA[3]	The lower 8 digits of the number of function codes M(L)
DATA[4]	The number of function codes corresponds to the number of bytes M*2. For example, write P05-07 alone, DATA[4] is P04
DATA[5]	Write the upper 8 bits of the starting function code, hexadecimal
DATA[6]	Write the lower 8 bits of the startfunction code, hexadecimal
DATA[7]	Write the upper 8 bits of the offset +1 in the starting function code group, hexadecimal
DATA[8]	Write the lower 8 bits of the offset +1 in the start function code group, hexadecimal
CRCL	CRC check low significant byte
CRCH	CRC check high significant byte
END	Greater than or equal to 3.5 characters of idle time, end of one frame

response frame format:

START	Greater than or equal to 3.5 characters of idle time, indicating the start of a frame	DATA[2]	Write data high byte, hex
ADDR	Servo axis address, hexadecimal data.	DATA[3]	Write data low byte, hex
CMD	Command code, 0x10	CRCL	CRC check low significant byte
DATA[0]	The group number of the written function code, such as writing function code P11-12, 0x11	CRCH	CRC check high significant byte
DATA[1]	The written function code offset, such as writing function code P06-11, it is 0x0B	END	Greater than or equal to 3.5 characters of idle time, end of one frame

Chapter 7 Troubleshooting

7.1 Fault and warning handling at startup

7.1.1 Position control mode

➤ Fault inspection

Boot process	Failure phenomenon	Reason	Confirmation method
Turn on the control power (L1C L2C)	The digital tube does not light up or does not display "rdy"	1. Control power supply voltage failure	<ul style="list-style-type: none"> ◆ After unplugging CN1, CN2, CN3, CN4, the fault still exists ◆ Measure the AC voltage between (L1C, L2C).
		2. Main power supply voltage failure	<ul style="list-style-type: none"> ◆ Single-phase 220V power supply models measure the AC voltage between (L1, L2). The main power supply DC bus voltage amplitude (voltage between B1/⊕, 1) is lower than 200V, and the digital tube displays "nrd". ◆ Three-phase 220V/380V power supply models measure the AC voltage between (L1, L2, L3). The main power supply DC bus voltage amplitude (voltage between B1/⊕ and 1) is lower than 460V and the digital tube displays "nrd".
		The terminal is short	◆ Check the terminal of the programming program to confirm whether it is short-circuited.
		4. Servo drive failure	◆ -
	Display "FU.xxx"	Refer to Chapter 7.2 to find the cause and eliminate the fault.	
■ After troubleshooting the above fault, the panel should display "rdy".			
Servo enable signal is valid (S-ON is ON)	Display "FU.xxx"	Refer to Chapter 7.2 to find the cause and eliminate the fault.	
	Servo motor shaft is in free running state	1. The servo enable signal is invalid	<ul style="list-style-type: none"> ◆ Switch the panel to the servo status display, and check whether the panel displays "rdy" instead of "run". ◆ Check P03 and P17 groups, whether to set the servo enable signal (DI function 1: S-ON). If it has been set, check whether the corresponding terminal logic is valid; if not, set it and make the terminal logic valid. Refer to Chapter 6 "P03 Group: Terminal Input Parameters" setting method. ◆ If the P03 group has set the servo enable signal and the corresponding terminal logic is valid, but the panel still displays "rdy", then check whether the DI terminal wiring is correct. Refer to Chapter 5.
		2. Wrong control mode selection	◆ Check whether P02-00 is 1. If it is set to 2 by mistake (torque mode), the motor shaft is also in free running state because the default torque command is zero.
■ After troubleshooting the above fault, the panel should display "run".			
Input position command	Servo motor does not rotate	Input position command counter (P0B-13) is 0	<ul style="list-style-type: none"> ◆ High/low speed pulse port wiring error When P05-00=0 pulse command source, check whether the high/low speed pulse port wiring is correct, please refer to Chapter 5 "Wiring", and check whether the setting of P05-01 matches. ◆ Position command not entered 1. Whether to use DI function 13 (FunIN.13: Inhibit, position command prohibition) or DI function 37 (FunIN.37: PulseInhibit, pulse command prohibition) 2. When P05-00=0 pulse command source, the host computer or other pulse output device does not output pulses. Use an oscilloscope to check whether there is pulse input at the high/low speed pulse port. Please refer to Chapter 5 "Wiring"; 3. When P05-00=1 step command source, check whether P05-05 is 0, if it is not 0, check whether DI function 20 (FunIN.20: PosStep, step command enable) and corresponding Whether the terminal logic is valid; 4. When P05-00=2 multi-segment position command source, check whether the P11 group parameters are set correctly, if

			<p>correct, check whether DI function28 (FunIN.28: PosInSen, internal multi-segment position enable) and the corresponding terminal logic are valid. ;</p> <p>5. If you have used the interrupt fixed-length function, check whether P05-29 is 1, (after the interrupted fixed-length operation is completed, can you directly respond to other position commands), if it is 1, confirm whether to use DI function 29 (FunIN.29: XintFree, interrupt fixed-length state release) release the locked state.</p>
	Servo motor reverse	Input position command counter (P0B-13) is negative	<p>◆ When P05-00=0 is the source of pulse command, check whether the parameter setting of P05-15 (pulse command form) corresponds to the actual input pulse. If it is inconsistent, the setting of P05-15 is wrong or the terminal wiring is wrong;</p> <p>◆ P05-00=1 when the step command source, check the positive and negative values of P05-05;</p> <p>◆ P05-00=2 When the multi-segment position command source, check the positive and negative of each segment of the P11 group;◆ Check whether DI function 27 (FunIN.27: PosDirSel, position command direction setting) has been set and whether the corresponding terminal logic is valid;</p> <p>Check whether the P02-02 parameter is set incorrectly.</p>
<p>■ After troubleshooting the above fault,the motor can rotate.</p>			
Unstable rotation at low speed	Unstable speed when rotating at low speed	Unreasonable gain setting	◆ Automatic gain adjustment.
	Motor shaft vibration left and right	Load moment of inertia ratio(P08-15) too large	<p>◆ If it can be operated safely, perform inertia identification again;</p> <p>◆ Automatic gain adjustment</p>
<p>■ After troubleshooting, the servo motor can rotate normally.</p>			
Normal operation	No location	Creating non-compliant locations Deviation	◆ Determine the input position instruction counter (P0B-13), feedback pulse counter (P0B-17) and mechanical stop position. the confirmation steps are as follows.

➤ Fault Cause Checking Steps for Untimely Positioning

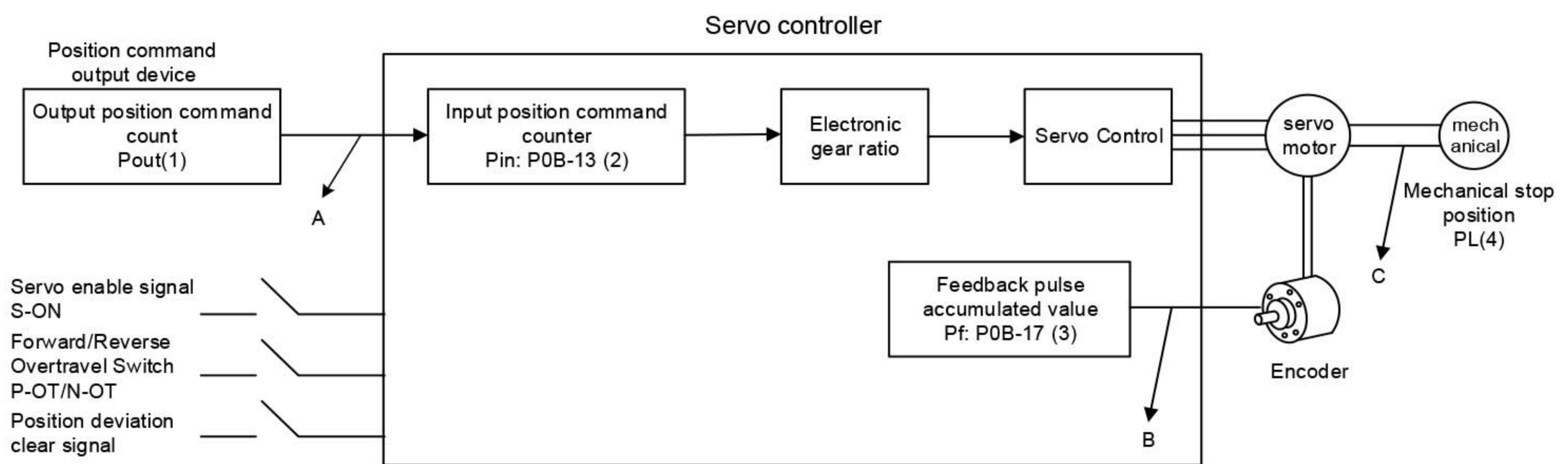

Figure 7-1 Block diagram of positioning control principle

- Check the 4 signals above when the location is not correct:

- 1)Count value Pout; of output position instruction in position instruction output device;
- 2)The input position instruction counter received by the servo controller Pin, correspondsto the parameter P0B-13;
- 3)The cumulative value of feedback pulse of servo motor with encoder Pf, corresponding to parameter P0B-17;

4) PL of mechanical stops.

- 3 reasons for incorrect positioning, corresponding to the A、 B、 C, in the graph:

A means that the input bit is caused by noise in the connection between the output device of the 1 :1 position instruction (especially the upper computer) and the servo driver

Set instruction count error;

During the operation of the motor, the input position instruction is interrupted.

Reason: servo enable signal is invalid (S-ON OFF), forward / reverse overrun switch signal (P-OT or N-OT) has Effect, position deviation clearance signal (ClrPosErr) is effective;

B representation: encoder feedback position signal error (signal interference).

C representation: mechanical position sliding occurs between machinery and servo motor. In an ideal state • where there is no positional deviation, the following relationship holds:

$P_{out} = P_{in}$, Output position instruction count value = input position instruction counter

$P_{in} \times \text{Electronic gear ratio} = P_f$, Input position instruction counter \times Electronic gear ratio = Feedback pulse accumulation

$P_f \times \Delta L = PL$, Feedback pulse accumulation \times 1 position instruction corresponds to load displacement = Position of mechanical stop

- In the event of inaccurate positioning, check method:

a) $P_{out} \neq P_{in}$

Failure cause : A

Exclusion Methods and Steps:

① Check pulse input terminals (For low-or high-speed pulse input terminals, refer to Chapter 5, "Wiring ") Whether use double stranded shield;

② If the open circuit input mode of collector in low speed pulse input terminal is selected, it should be changed to differential input mode;

③ Connection of pulse input terminals must be separated from the main circuit (L1C、 L2C、 L1L 2L3、 U、 V、 W) line;

④ A low-speed pulse input terminal is selected to increase the filter time constant (P0A-24);

Conversely, the high-speed pulse input terminal is selected to increase the filter time constant of the high-speed pulse input pin (P0A-30).

b) $P_{in} \times \text{Electronic gear ratio} \neq P_f$

Failure cause : B

Exclusion Methods and Steps:

① Check to see if there is a operation, resulting in the instruction not being fully executed and the servo has stopped;

② When the position deviation clearance signal (ClrPosErr) is valid, check whether the position deviation clearance mode (P05-16) is reasonable.

c) $P_f \times \Delta L \neq PL$

failure cause : C

Exclusion Methods and Steps: Check the mechanical connection step by step to find the position where the relative sliding occurs.

7.1.2 Speed Control Mode

start-up	Error	Reason	Confirmation way
----------	-------	--------	------------------

procedure			
Switch on Main power source (L1 L2)	Digital tube not on or on“ rdy”	1. Control power supply voltage failures	◆ After pulling out the CN1、CN2、CN3、CN4, the fault still exists。
		2. Main supply voltage faultMain supply voltage fault	◆ Single phase 220 V power supply model measurement (L1、L2) between the AC voltage. Main power DC bus voltage amplitude (B1/⊕, ⊖ 1 voltage) less than 200 V digital tube display nrd"
		3. Short connection of burn program terminals	◆ Check the terminal of the burning program to confirm that it is short connected.
		4. Servo Driver Failure	-
	Panel display “FU.xxx”	Refer to Section 7.2 to find causes and troubleshoot	
■ After troubleshooting, the panel should display rdy"			
Servo enable signal set to be effective (S-ON is ON)	Panel display “FU.xxx”	Refer to Section 7.2 to find causes and troubleshoot	
	Shaft of servo motorIn free state	1. Servo enable signal invalid	◆ Switch the panel to the servo state display to see if the panel is displayed as “Rdy “ , instead of “ run”. ◆ View P03 and P17 groups to set servo enable signals (DI function 1: S-ON). If set, see if the corresponding terminal logic is valid; if not, set and make the terminal logic valid. Can refer to Chapter 6" Group P03: Terminal Input Parameters "setting method。 ◆ When the P03 group has set the servo enable signal and the corresponding terminal logic is valid, but the panel still displays "rdy" ,, check that the DI terminal wiring is correct, refer to Chapter 5.
		2. Control mode selection error	◆ Check to see if the P02-00 is 0, and if it is set to 2(torque mode), the motor shaft is also in free operation because the default torque instruction is zero.
■ After troubleshooting, the panel should show“ run” 。			
Input speed instruction	The servo motor does not rotate or rotate incorrectly	speed instruction (P0B-01)0	◆ AI wiring error When selecting analog input instructions, first check whether the AI analog input channel is selected correctly, and then check whether the AI terminal wiring is correct please refer to Chapter 5。 Speed instruction selection error Check if the P06-02 is set correctly ◆ No speed instruction input or speed instruction exception 1. select analog input instruction, first check whether the relevant parameters AI P03 group are set correctly; then check whether the input voltage signal of external signal source is correct, can be observed by oscilloscope or read by P0B-21 or P0B-22; 2. the numbers to see if the P06-03 is correct; 3. multi-segment speed instruction to timing to see if P12 set parameters are correct; 4. communication timing to see if the P31-09 is correct; 5. the timing of the point speed instruction to see if the P06-04 is correct DI functions 18 and 19 have beenset, and whether the corresponding terminal logic is valid; 6. see if the acceleration and deceleration time P06-05 and P06-06 settings are correct; 7. whether the zero-bit fixed function is incorrectly enabled, that is, to view the DI function; 8.Whether is mis-configured and whether DI valid logic of the corresponding terminal is correct.
Input speed instruction	Servo motor reversal	Velocity instruction (P0B-01) is negative	◆ When selecting analog input instruction, check whether the positive and negative polarity of input signal is reverse; ◆ Digital timing to see if the P06-03 is less than 0; ◆ A multi-segment speed instruction is given timing to view the positive and negative of each group of speed instructions in P12 group;

			<ul style="list-style-type: none"> ◆ Communication timing to see if the P31-09 is less than 0; ◆ Point speed instruction gives timing to see if the P06-04 value, DI function 18,19 valid logic and expected steering match; ◆ See if the DI function 26(FunIN.26: SpdDirSel, speed instruction direction setting) and the corresponding terminal logic are valid; ◆ Check to see if the P02-02 parameter is set incorrectly.
	<p>■ After troubleshooting, the servo motor can rotate</p>		
Low speed rotation	Unstable speed at low speed rotation	Unreasonable gain setting	◆ Automatic gain adjustment.
	Motor shaft left and right vibration	Load moment of inertia ratio(P08-15) Too big	<ul style="list-style-type: none"> ◆ If it can operate safely, the inertia identification is carried out again; ◆ Automatic gain adjustment.

7.1.3 Torque Control Mode

Start-up procedure	Fault phenomenon	Reason	Confirmation method
Switch on MainPower (L1 L2)	The digital tube is not on "rdy"	1、 Control power supply voltage failures	◆ After pulling out the CN1、 CN2、 CN3、 CN4, the fault still exists。
		2、 Control power supply voltage failures	<ul style="list-style-type: none"> ◆ Single phase 220 V power supply model measurement (L1、 L2) between the AC voltage. Main power DC bus voltage amplitude (B1/⊕,1 voltage) less than 200 V digital tube display nrd". ◆ Three-phase 220 V/380V power supply model measurement (L1L2L3) between the AC voltage. Main power supply DC bus voltage amplitude (B1/⊕,1 voltage) less than 460 V digital tube display nrd".
		3、 Short connection of burn program terminals	◆ Check the terminal of the burning program to confirm that it is short connected.
		4、 Servo Driver Failure	-
	panel display "FU.xxx"	Refer to Section 6.2 to find out the cause and troubleshoot.	
<p>■ After troubleshooting the above, the panel rdy".</p>			
Servo enable signal set to be effective (S-ON set ON)	Panel display "FU.xxx"	Refer to Section 6.2 to find out the cause and troubleshoot.	
	The axis of the servo motor is in free running state	Servo enable signal invalid	<ul style="list-style-type: none"> ◆ Switch the panel to the servo state display to see if the panel is displayed as Rdy ", instead of run". ◆ View P03and P17 groups to set servo enable signals (DI function 1: S-ON). If set, see if the corresponding terminal logic is valid; if not, set and make the terminal logic valid. Refer to Chapter 6, P03 Group: terminal input parameters setting method. ◆ When the P03 group has set the servo enable signal and the corresponding terminal logic is valid, but the panel still displays "rdy", check that the DI terminal wiring is correct, refer to Chapter 5
	<p>■ After troubleshooting, the panel should display run".</p>		

Input torque instruction	Servo motor not rotating	Internal torque instruction (P0B-02)0	AI wiring error For analog input instructions, see if the AI terminal wiring is correct, please refer to Chapter 4. Error in selecting torque instruction Check that the P07-02 is set correctly. No torque instruction entered When 1. select analog input instruction, first check whether the relevant parameters AI P03 group are set correctly; then check whether the input voltage signal of external signal source is correct, can be observed by oscilloscope or read by P0B-21 or P0B-22; 2. the number to time to see if the P07-03 is 0; 3. communication to timing to see if the P31-11 is 0.
Input torque instruction	Servo motor reversal	Internal torque instruction (P0B-02) is negative	<ul style="list-style-type: none"> ◆ When the analog input instruction is selected, whether the input voltage polarity of the external signal source is reverse can be viewed by oscilloscope or through P0B-21 or P0B-22; ◆ Digital timing to see if the P07-03 is less than 0; ◆ Communication timing to see if the P31-11 is less than 0; ◆ See if the DI function 25(FunIN.25: ToqDirSel, torque instruction direction setting) and the corresponding terminal logic are valid; ◆ Check to see if the P02-02 parameter is set incorrectly.
			<ul style="list-style-type: none"> ■ After removing the above fault, the servo motor can rotate.
Low speed rotation	Unstable speed at low speed rotation	Unreasonable gain setting	◆ Automatic gain adjustment.
	Motor shaft left and right vibration	Load moment of inertia ratio (P08-15) Too big	◆ If it can run safely, the inertia identification is carried out again, and the automatic gain adjustment is carried out.

7.2 Runtime failures and warning handling

7.2.1 Fault and Warning Code Table

1) Fault and warning classification

Servo drive failures and warnings are classified by severity into three categories ,1,2,3, severity :1>2>3,

as follows:

- Category 1(NO.1) Non-resetable faults;
- Class 1(NO.1) Resetable faults;
- Class 2(NO.2) Resetable faults;
- Class 3(NO.3) Resetable warning。

"Resetable" means to stop the panel failure display by giving a reset signal.

Specific operation: set parameter P0D-01=1(fault reset) or use DI function 2(FunIN.2: ALM-RST, fault and warning reset) and set to logic valid, can make panel stop fault display.

NO.1、 NO.2 reset method of resetable fault: turn off servo enable signal (S-ON set to OFF), then set P0D-01=1 or use DI function 2.

NO.3 reset method of resetable warning: set P0D-01=1 or use DI function

Notes:■ for some faults or warnings, you must change the settings to remove the cause before reset, but reset does not mean that the change takes effect. For changes that need to be re-controlled (L1C、 L2C) to take effect, the control power must be re-controlled; for changes that require downtime to take effect, the servo enable must be turned off. After the change takes effect, the servo drive can run normally.

☆Association function code:

Function code	Name	Setting range	Unit	Factory setting	Setting	Effective time	Relevant models
P0D 01	Fault reset	0: no operation 1: failure and warning reset	-	0	Stop setting	take effect	-

☆Associated function number:

Function code	Name	Function name	Function
FunIN.2	ALM-RST	Failure and warning reset signal	<ul style="list-style-type: none"> ◆ The DI function is edge effective, the level continues to be high / low usually invalid. ◆ According to the alarm type, some alarm reset servo can continue to work. ◆ When assigned to low speed DI, if the DI logic is set to level effective, it will be forced to be effective along the change, and the effective level change must be kept above 3 ms, otherwise the fault reset function will be invalid. Do not assign fault reset function to fast DI, otherwise function is invalid. Invalid, no reset fault and warning; valid, reset fault and warning.

1) Failure and warning records

The servo driver has the function of fault recording, which can record the last 10 faults and warning names and the state parameters of the servo driver when the fault or warning occurs. If repeated failures or warnings occur in the last 5 times, the fault or warning code, that is, the drive status, is recorded only once.

After the fault or warning reset, the fault record will still save the fault and warning; use the system parameter initialization function (P02-31=1 or 2) to clear the fault and warning record.

Through monitoring parameters P0B-33 you can select the number of failures or warnings from the current fault n, P0B-34 you can view the n 1 fault or warning name, P0B-35~P0B-42 you can view the status parameters of the servo driver when the first fault or warning occurs. FU.000". P0B-34 on panel when failure occurs

When viewing the P0B-34(n 1 fault or warning name) through the panel, the panel displays "FU.xxx", "xxx" as fault or warning code; when reading through driving debugging platform software or communication, it reads decimal data of the code. It needs to be converted into hexadecimal data to reflect real fault or warning code, such as

Panel displays failures or warnings“ FU.xxx”	P0B-34 (decimal system)	P0B-34 (hexadecimal)	Illustration
FU.101	257	0101	0: Class 1 Non-resetable Fault 101: Fault Code
FU.130	8496	2130	2: Class 1 Resetable Fault 130: Fault Code
FU.121	24865	6121	6: Class 2 Resetable Fault 121: Fault Code
FU.110	57616	E110	E: Class 3 Resetable Warning 110: Warning Code

(3)Fault and Warning Code Output

Servo drives can output the current highest level of fault or warning codes.

"Fault coded output" means setting 3 DO terminals of the servo drive to DO functions 12,13,14, FunOUT.12of which

ALMO1(alarm code bit 1, abbreviated asAL1), FunOUT.13:

ALMO2(alarm code bit 2, abbreviated asAL2), FunOUT.14:

ALMO3(alarm code 3, abbreviated asAL3).

Different faults occur, the level of 3 DO terminals will change.

a)Category 1(NO.1) Non-reset faults:

Display	Fault name	Fault type	Resets	Coding output		
				AL3	AL2	AL1
FU.101	P02 and above group parameters are abnormal	NO.1	No	1	1	1
FU.102	Programmable logic configuration failure	NO.1	No	1	1	1
FU.104	Programmable logic interrupt fault	NO.1	No	1	1	1
FU.105	Internal program exception	NO.1	No	1	1	1
FU.108	Parameter storage failure	NO.1	No	1	1	1
FU.111	Internal fault	NO.1	No	1	1	1
FU.120	Product matching failure	NO.1	No	1	1	1
FU.122	Absolute position mode product matching failure	NO.1	No	1	1	1
FU.136	Data check error in motor ROM or parameter not saved	NO.1	No	1	1	1
FU.201	Over current 2	NO.1	No	1	1	0
FU.208	FPGA system sampling operation timeout	NO.1	No	1	1	0
FU.210	Output short circuit to ground	NO.1	No	1	1	0
FU.220	Phase sequence error	NO.1	No	1	1	0
FU.234	Speed car	NO.1	No	1	1	0
FU.740	Encoder interference	NO.1	No	1	1	1
FU.A33	Encoder data is abnormal	NO.1	No	0	1	0

Note : "1" means valid , "0" means invalid, does not represent the level of the DO terminal.

b)Class 1(NO.1) Resetable faults:

Display	Fault name	Fault type	Resets	Encoding output		
				AL3	AL2	AL1
FU.130	DI function repeated allocation	NO.1	Yes	1	1	1
FU.131	DO function allocation exceeds limit	NO.1	Yes	1	1	1
FU.207	D/Q axis current overflow fault	NO.1	Yes	1	1	0
FU.400	Main circuit over voltage	NO.1	Yes	0	1	1
FU.410	Main circuit under voltage	NO.1	Yes	1	1	0
FU.602	Angle recognition failed	NO.1	Yes	0	0	0

C)Class 2(NO.2) Resetable faults:

Display	Fault name	Fault type	Resets	Encoding output		
				AL3	AL2	AL1
FU.121	Servo ON command invalid fault	NO.2	Yes	1	1	1
FU.420	Main circuit lack of phase	NO.2	Yes	0	1	1
FU.430	Control voltage under voltage	NO.2	Yes	0	1	1
FU.500	Over speed	NO.2	Yes	0	1	0
FU.510	Pulse output over speed	NO.2	Yes	0	1	0
FU.610	Drive overload	NO.2	Yes	0	0	0
FU.620	Motor over load	NO.2	Yes	0	0	0
FU.625	Brake closed abnormally	NO.2	Yes	0	0	0
FU.626	Brake opened abnormally	NO.2	Yes	0	0	0
FU.630	Motor blocked	NO.2	Yes	0	0	0
FU.650	Radiator overheated	NO.2	Yes	0	0	0
FU.731	Encoder battery failure	NO.2	Yes	1	1	1
FU.733	Encoder multi-turn counting error	NO.2	Yes	1	1	1
FU.735	Encoder multi-turn counting over flow	NO.2	Yes	1	1	1
FU.834	AD sampling overvoltage	NO.2	No	1	1	1
FU.835	High-precision AD sampling failure	NO.2	No	1	1	1
FU. B00	Position deviation is too large	NO.2	Yes	1	0	0
FU.B01	Pulse input abnormal	NO.2	Yes	1	0	0
FU.B02	Full closed loop position deviation is too large	NO.2	Yes	1	0	0
FU.B03	Electronic gear ratio setting exceeds limit	NO.2	Yes	1	0	0

FU.B04	Full closed loop function parameter setting error	NO.2	Yes	1	0	0
FU.D03	CAN communication connection interrupted	NO.2	Yes	1	0	1

d) Warning reset:

Display	Warning name	Fault type	Resets	Encoding output		
				AL3	AL2	AL1
FU.110	Frequency division pulse output setting failure	NO.3	Yes	1	1	1
FU.601	Back to origin timeout failure	NO.3	Yes	0	0	0
FU.730	Encoder battery warning	NO.3	Yes	1	1	1
FU.831	AI zero drift is too large	NO.3	Yes	1	1	1
FU.900	DI emergency brake	NO.3	Yes	1	1	1
FU.909	Motor overload warning	NO.3	Yes	1	1	0
FU.920	Braking resistor overload	NO.3	Yes	1	0	1
FU.922	External braking resistor is too small	NO.3	Yes	1	0	1
FU.939	Motor power line is broken	NO.3	Yes	1	0	0
FU.941	Change parameters need to be re-powered to take effect	NO.3	Yes	0	1	1
FU.942	Frequent parameter storage	NO.3	Yes	0	1	1
FU.950	Forward over travel warning	NO.3	Yes	0	0	0
FU.952	Reverse over travel warning	NO.3	Yes	0	0	0
FU.980	Encoder internal fault	NO.3	Yes	0	0	1
FU.990	Input phase loss warning	NO.3	Yes	0	0	1
FU.994	CAN address conflict	NO.3	Yes	0	0	1
FU.A40	Internal fault	NO.3	Yes	0	1	0

7.2.2 Trouble shooting method

FU.101: Abnormal servo internal parameters

1) Production mechanism:

The total number of function codes has changed, which usually appears after updating the software;

The function code parameter values of P02 group and later groups exceed the upper and lower limits, which usually appear after updating the software.

Reason	Confirmation method	Treatment measures
1. Control power supply voltage drops instantaneously	<ul style="list-style-type: none"> ◆ Measure whether the input voltage on the non-drive side of the control cable meets the following specifications during operation: ◆ 220V drive: ◆ Effective value: 220V-240V ◆ Allowable deviation: -10%~+10% (198V~264V) 	Increase the power supply capacity or replace a large-capacity power supply. After the system parameters are restored and initialized (P02-31=1), rewrite the parameters.
2. Instantaneous power failure during parameter storage	<ul style="list-style-type: none"> ◆ Confirm whether an instantaneous power failure occurs during parameter value storage. 	Re-power on and re-write the parameters after the system parameters are restored and initialized (P02-31=1).
3. The number of writes of the parameter within a certain period of time exceeds the maximum	<ul style="list-style-type: none"> ◆ Check whether the upper device frequently changes parameters. 	Change the parameter writing method and rewrite. Or the servo drive is faulty, replace the servo drive.
4. Updated software	<ul style="list-style-type: none"> ◆ Confirm whether the software has been updated. 	Reset the drive model and motor model, and the system parameters are restored and initialized (P02-31=1)
5. Servo drive failure	<ul style="list-style-type: none"> ◆ After turning on the power supply several times and restoring the factory parameters, if the fault is still reported, the servo drive has a fault. 	Replace the servo drive

2) FU.102: Programmable logic configuration failure

Production mechanism:

- FPGA and MCU software versions do not match;
- The FPGA or MCU related hardware is damaged, causing the MCU and FPGA to fail to establish communication

Reason	Confirmation method	Treatment measures
1. FPGA and MCU software version is not match	◆ Check the MCU software version number P01-00 and FPGA software version number P01-01 through the panel or drive debugging platform, etc., and confirm whether the highest non-zero values of the two software version numbers are consistent.	Consult our technical support to update the FPGA or MCU software that matches each other.
2. FPGA Fault	◆ The fault is still reported after turning on the power several times.	Replace the servo drive

3) FU.104: Programmable logic interrupt fault

In order to distinguish the mechanism of the fault, the servo drive can display different internal fault codes under the same external fault code, which can be checked through P0B-45.

Production mechanism:

- MCU or FPGA access timeout

Reason	Confirmation way	Settlement way
1. FPGA fault (FU.104)	◆ The fault is still reported after turning on the power several times.	Replace the servo drive
2. Handshake between FPGA and MCU is abnormal (FU.100)		
3. Drive internal operation timeout (FU.940)		

4) FU.105: Internal program exception Production mechanism:

Production mechanism:

- When EEPROM read/write function codes, the total number of function codes is abnormal.
- The range of the function code setting value is abnormal (usually after updating the program)

Reason	Confirmation way	Settlement way
1. EEPROM error	◆ Confirm according to the method of FU.101.	After the system parameters are restored and initialized (P02-31=1), power on again
2. Servo drive error	◆ The fault is still reported after turning on the power several times.	Replace the servo drive

5) FU.108: Parameter storage failure

Production mechanism:

- Parameter value cannot be written to EEPROM; parameter value cannot be read from EEPROM.

Reason	Confirmation way	Settlement way
1. Parameter writing is abnormal	◆ After changing a parameter, power on again to check whether the parameter value is saved.	It is not saved, and the fault still occurs after multiple power-on. The drive needs to be replaced.
2. Parameter reading is abnormal		

6) FU.120: Product matching failure Production mechanism:

Production mechanism:

- The motor and driver do not match or the parameter setting is wrong.

Reason	Confirmation way	Settlement way
1. Product number (motor or drive) does not exist	Internal fault code P0B45=0120 or 1120 ◆ Check whether the motor nameplate is matched by our company. According to the motor nameplate, confirm whether the setting of P00-00 is correct.	Reset P00-00 (motor number) according to the motor nameplate or replace with a matching motor.

	Internal fault code P0B45=2120 ◆ Check the drive model (P01-02) to see if there is this drive model.	The drive number does not exist. Set the correct drive model according to the drive nameplate.
2. The power level of the motor and the drive do not match	Internal fault code P0B45=3120 ◆ Check the drive model (P01-02) whether it matches with the bus motor model (P00-05).	Replace the product that does not match

7)FU.121: Servo ON command invalid fault

Production mechanism:

- When using some auxiliary functions, a redundant servo enable signal is given

Reason	Confirmation way	Settlement way
1. When internally enabled, external Servo enable signal (S-ON) is valid	◆ Confirm whether to use auxiliary functions: P0D-02, P0D-03, P0D-12, and DI function 1 (FunIN.1: S-ON, servo enable signal) is valid.	Set DI function 1 (including hardware DI and virtual DI) signals to be invalid.

8)FU.122: Absolute position mode product matching failure Production mechanism:

- Absolute position mode motor does not match or the motor number is set incorrectly

Reason	Confirmation way	Settlement way
In the absolute position mode, the detected motor does not match or the motor number is set incorrectly	◆ Check whether the motor nameplate is a multi-turn absolute encoder motor. ◆ Check whether P00-00 (motor number) is correct.	Reset P00-00 (motor number) according to the motor nameplate or replace with a matching motor.

9)FU.130: DI Duplicate function assignment Production mechanism:

- The same DI function is allocated repeatedly, including hardware DI and virtual DI. ● DI the function number exceeds the number of DI functions.

Reason	Confirmation way	Settlement way
1. When DI function is allocated, the same function is repeatedly allocated to multiple DI terminals	◆ Check whether P03-02/P03-04..P03-20, P17-00/P17-02..P17-30 are set with the same non-zero DI function number.	Re-assign the parameters of group P03 and P17 assigned the same non-zero function number to different function numbers, and then power on again to make the changes take effect, or turn off the servo enable signal first and give a "reset signal" "To make the changes take effect.
2. DI function number exceeds the number of DI functions	◆ Has the MCU program been updated?	After the system parameters are restored and initialized (P02-31=1), power on again.

10)FU.131: DO Function allocation exceeds limit Production mechanism:

- DO The function number exceeds the number of DO functions.

Reason	Confirmation way	Settlement way
1. The function number exceeds the number of DO functions.	◆ Has the MCU program been updated?	After the system parameters are restored and initialized (P02-31=1), power on again.

11)FU.136: The data in the motor encoder ROM is checked incorrectly or parameters are not stored Production mechanism:

- When the drive reads the parameters of the encoder ROM area, it is found that the parameters are not stored, or the parameters are inconsistent with the agreed values.

Reason	Confirmation way	Settlement way
1. The drive and motor type do not match	<ul style="list-style-type: none"> ◆ According to motor brand and motor model type, ensure P00-00 setting correct ◆ For this series of drives and 17bit servo motors (-U2***), check whether P00-00 (motor number) is 14130. 	<p>Replace with a matching drive and motor, and power on again.</p> <ul style="list-style-type: none"> ■ When using our driver and 17bit/23 bit servo motor, make sure that P00-00= 14130.
2. Drive failure	<ul style="list-style-type: none"> ◆ The fault is still reported after power-on again. 	Replace the servo drive

12)FU.201: over current 2

Production mechanism:

- Overcurrent detected by hardware

Reason	Confirmation way	Settlement way
1. The input command is synchronized with the servo on or the input command is too fast	<ul style="list-style-type: none"> ◆ Check whether the command has been input before the servo panel displays "Rdy". 	Command sequence: After the servo panel displays "Rdy", turn on the servo enable signal (S-ON) first, and then input the command. If allowed, add the command filter time constant or increase the acceleration/deceleration time.
1.Braking resistance is too small or short circuited	<ul style="list-style-type: none"> ◆ If using the built-in braking resistor (P02-25=0), confirm whether B2 and B3 are reliably connected by wires. If yes, measure the resistance between B1/⊕ and B3; ◆ If using an external braking resistor (P02-25=1/2), measure the resistance of the external braking resistor between B1/⊕ and B2. ◆ Please refer to Chapter 1 for brake resistor specifications. 	If the built-in braking resistor is used and the resistance value is "0", then adjust to use an external braking resistor (P02-25=1/2), and remove the wire between B2 and B3. The resistance value and power can be selected as the internal. The specifications of the braking resistors are the same; if an external braking resistor is used, the resistance value is less than P02-21, refer to Chapter 1 "Specifications of braking resistors", replace with a new resistor, and reconnect between B1/⊕ and B2. Be sure to set P02-26 (power of external braking resistor) and P02-27 (resistance value of external braking resistor) consistent with the actual parameters of external braking resistor.
3. Poor contact of the motor cable	<ul style="list-style-type: none"> ◆ Check whether the connections between the two ends of the drive power cable and the U V W side of the drive in the motor cable are loose. 	Tighten loose or detached wiring.
4. Ground the motor cable	<ul style="list-style-type: none"> ◆ After ensuring that the drive power cable and motor cable are tightly connected, respectively measure whether the insulation resistance between the UVW end of the drive and the ground wire (PE) is a megaohm (MΩ) value. 	Replace the motor when the insulation is poor.
5. Short circuit of motor U V W cable	<ul style="list-style-type: none"> ◆ Unplug the motor cable and check whether there is a short circuit between the motor cable U V W and whether there are burrs in the wiring. 	Connect the motor cables correctly.
6. Motor burns out	<ul style="list-style-type: none"> ◆ Unplug the motor cable and measure whether the resistance of the motor cable U V W is balanced. 	If unbalanced, replace the motor.
7. Unreasonable gain setting, motor oscillation	<ul style="list-style-type: none"> ◆ Check whether the motor vibrates or has a sharp sound during the startup and operation of the motor. You can also use the drive debugging platform to view the "current feedback". 	Make gain adjustments.
8. Encoder wiring error, aging and corrosion, encoder plug loose	<ul style="list-style-type: none"> ◆ Check whether the standard encoder cable of our company is used, and whether the cable is aging, corroded, or the connector is loose. ◆ Turn off the servo enable signal, turn the motor shaft by hand, and check whether P0B-10 changes with the rotation of the 	Re-solder, plug tightly or replace the encoder cable.

	motor shaft.	
9. Drive failure	◆ Unplug the motor cable and power on again, the fault is still reported.	Replace the servo drive.

13)FU.207: D/Q Shaft current overflow fault

Production mechanism:

- Abnormal current feedback causes the internal registers of the driver to overflow;
- Abnormal encoder feedback causes the internal registers of the drive to malfunction.

Reason	Confirmation way	Settlement way
1.DQ Shaft current overflow	◆ When the fault is reported after turning on the power several times, the servo drive has a fault.	Replace the servo drive.

14)FU.208: FPGASystem sampling operation timeout

Production mechanism:

- When FU.208 occurs, please use the internal fault code (P0B-45) to query the cause of the fault.

Reason	Confirmation way	Settlement way
1.MCU Communication timeout	◆ Internal fault code P0B-45=1208: Internal chip is damaged	Replace the servo drive.
2.Encoder communication timeout	Internal fault code P0B-45=2208: ◆ Encoder wiring error ◆ The encoder cable is loose ◆ Encoder cable is too long ◆ Encoder communication is disturbed ◆ Encoder failure	◆ The cables are given priority to use our standard cables. If the cables are non-standard, check whether the cables meet the specifications and use twisted-pair shielded cables; ◆ Check whether the plugs at both ends of the encoder are in good contact, and whether the needles are retracted, etc.; ◆ Please contact the manufacturer; ◆ Separate the strong and weak currents as far as possible, the motor cables and encoder cables should not be bundled, and the grounding of the motor and driver should be well released; ◆ Replace the servo motor.
3. Current sampling timeout	Internal fault code P0B-45=3208: ◆ Check whether there is interference from large-scale equipment on site, or whether there are multiple sources of interference such as multiple power supply and frequency conversion equipment in the cabinet; ◆ The internal current sampling chip is damaged.	◆ Separate the strong and weak currents as far as possible and do not bundle the wires on site; ◆ Replace the servo driver.
4. High precisionAD conversion timeout	Internal fault code P0B-45=4208: ◆ There is interference in the high-precisionAI channel wiring. Refer to the correct wiring diagram to check theAI channel wiring.	Use twisted-pair shielded wire to re-wire to shorten the line length.
5. FPGAoperation timeout	Internal fault code P0B-45=0208: ◆ Check the cause according to the reason 1/2/3/4.	Check the cause according to the reason 1/2/3/4

15)FU.210: Output short circuit to ground Pro

duction mechanism:

- During the drive power-on self-test, abnormal motor phase current or bus voltage is detected.

Reason	Confirmation way	Settlement way
1. Drive power cable (U V W)is short-circuited to ground	◆ Unplug the motor cable and measure whether the drive power cable U V W is short-circuited to the ground (PE).	Rewire or replace the drive power cable

2. Motor short circuit to ground	◆ After ensuring that the drive power cable and motor cable are tightly connected, respectively measure whether the insulation resistance between the U V W end of the drive and the grounding wire (PE) is a megaohm (MΩ) value.	Replace motor
3. Drive failure	◆ The drive power cable is removed from the servo drive and the fault is still reported after turning on the power several times.	Replace servo drive

16)FU.220: Phase sequence error P

roduction mechanism:

- The drive performs angle identification, and it is recognized that the phase sequence of the drive UVW and the motor UVW do not match.

Reason	Confirmation way	Settlement way
The drive U V W and the motor UVW phase sequence do not correspond	◆ After repeated power-on, the angle recognition still reports FU.220 fault	Re-wire and perform angle recognition again.

17)FU.234: Speed car Pr

roduction mechanism:

- In torque control mode, the direction of torque command is opposite to the direction of speed feedback;
- In position or speed control mode, the speed feedback and speed command direction are opposite.

Reason	Confirmation way	Settlement way
1.U V W phase sequence wiring error	◆ Check whether the connections between the two ends of the drive power cable and the U V W end of the motor cable and the U V W end of the drive correspond one by one.	Wire in the correct U V W phase sequence.
2. When the power is turned on, the interference signal causes the initial phase detection error of the motor rotor	◆ U V W phase sequence is correct, but the servo drive is enabled, it will report FU.234.	Power on again.
3. Wrong encoder model or wrong wiring	◆ According to the drive and motor nameplate, confirm that P00-00 (motor number) is set correctly.	Replace with matching drivers and motors. Reconfirm P00 -00 (motor number), encoder wiring
4. Encoder wiring error, aging and corrosion, encoder plug loose	◆ Check whether the standard encoder cable of our company is used, and whether the cable is aging, corroded, or the connector is loose. ◆ Turn off the servo enable signal, turn the motor shaft by hand, and check whether P0B-10 changes with the rotation of the motor shaft.	Re-solder, plug tightly or replace the encoder cable.
5. Under the condition of vertical axis, the gravity load is too large	◆ Check whether the load of the vertical axis is too large, adjust the brake parameters of P02-09~P02-12, and whether the fault can be eliminated	Reduce the vertical shaft load, or increase the rigidity, or shield the fault without affecting safety and use.

Note: ■ Please set P0A-12=0 to shield the running fault under the condition of being towed and vertical axis.

18)FU.400: Mechanism of electrical overvoltage in the main circuit:

- B1/⊕、⊖ 1 Between the DC bus voltage exceeds the fault value:
220V servo drive: Normal value: 310V, fault value: 420V;

Reason	Confirmation way	Settlement way
1. The main circuit input voltage is too high	◆ Check the drive input power specification, and measure whether the input voltage of the main circuit cable	Replace or adjust the power supply according to the specifications on the left.

	drive side (L1 L2) meets the following specifications: 220V drive: Effective value: 220V-240V Allowable deviation: -10%~+10% (198V~264V)	
2. The power supply is in an unstable state or is affected by a lightning strike	◆ Monitor whether the input power of the drive is affected by lightning, and measure whether the input power is stable and meet the above specifications.	After connecting the surge suppressor, connect the control power and the main circuit power again. If the fault still occurs, replace the servo drive.
3. Braking resistor failure	<ul style="list-style-type: none"> ◆ If using the built-in braking resistor (P02-25=0), confirm whether B2 and B3 are reliably connected by wires. If so, measure the resistance between B1+and B3; ◆ If using an external braking resistor (P02-25=1/2), measure the resistance of the external braking resistor between B1+and B2. ◆ Please refer to Chapter 1.4for brake resistor specifications. 	<p>If the resistance value is "∞" (infinity), the internal brake resistor is disconnected: If the built-in braking resistor is used, adjust to use an external braking resistor (P02-25=1/2), and remove the wire between B2 and B3. The resistance value and power can be selected to be consistent with the built-in braking resistor; If an external braking resistor is used, replace it with a new resistor and reconnect it between B1+and B2. Be sure to set P02-26 (power of external braking resistor) and P02-27 (resistance value of external braking resistor) to be consistent with the actual parameters of external braking resistor.</p>
4. The resistance of the external braking resistor is too large, and the maximum braking energy cannot be completely absorbed	◆ Measure the resistance of the external braking resistor between B1+and B2 and compare it with the recommended value.	Change the resistance of the external braking resistor to the recommended value and reconnect it between B1 +and B2. Be sure to set P02 -26 (power of external braking resistor) and P02-27 (resistance value of external braking resistor) to be consistent with the actual parameters of external braking resistor.
5. When the motor is running in rapid acceleration and deceleration, the maximum braking energy exceeds the absorbable value	◆ Confirm the acceleration and deceleration time during operation, measure the DC bus voltage between B1+and N, and confirm whether the voltage exceeds the fault value during the deceleration stage.	First, ensure that the input voltage of the main circuit is within the specification range, and then increase the acceleration and deceleration time when allowed
6. The bus voltage sampling value has a large deviation	◆ Observe whether the parameter P0B-26 (bus voltage value) is in the following range: 220V driver: P0B-26 >420V Measure whether the DC bus voltage between B1+and 1 is at a normal value and is less than P0B-26.	Consult our technical support.
7. Servo drive failure	◆ After several power-offs, the main circuit is reconnected, and the fault is still reported.	Replace the servo drive.

19)FU.410: Main circuit undervoltage Prod

uction mechanism:

- B1+、NDC bus voltage is lower than the fault value:

220V servo drive: Normal value: 310V, Fault value: 200V;

Reason	Confirmation way	Settlement way
1. The main circuit power supply is unstable or out of power	<ul style="list-style-type: none"> ◆ Check the drive input power specifications, and measure whether the input voltage of the main circuit cable on the non-drive side and the drive side (L1 L2 L3) meets the following specifications:220V drive: Effective value: 220V-240V Allowable deviation: -10%~+10% (198V~264V) 	Increase power supply capacity.
2. Momentary power outage		

3. Power supply voltage drops during operation	◆ Monitor the input power supply voltage of the drive to check whether the power supply of the same main circuit is turned on too much and other settings cause insufficient power supply capacity and voltage drop.	
4.Servo drive failure	◆ Observe whether the parameter P0B-26 (bus voltage value) is in the following range: 220V Servo drive: P0B-26 <200V After multiple power-offs, the main circuit power (L1, L2) is reconnected to still report the fault.	Replace the servo drive.

20)FU.430: Control voltage undervoltage

Production mechanism:

- 220V servo drive: Normal value: 310V, Fault value: 190V;

Reason	Confirmation way	Settlement way
1. The control power supply is unstable or power failure	◆ Confirm whether it is in the process of cutting off the control power (L1C L2C) or momentary power failure occurs	Re-power on, if abnormal power failure occurs, ensure that the power supply is stable.
	◆ Measure whether the input voltage of the control cable meets the following specifications: 220V servo drive: Effective value: 220V-240V Allowable deviation: -10%~+10% (198V~264V)	Increase power supply capacity.

21)FU.500: over speed

Production mechanism:

- The actual speed of the servo motor exceeds the overspeed fault threshold

Reason	Confirmation way	Settlement way
1. Motor cable U V W phase sequence error	◆ Check whether the connections between the two ends of the drive power cable and the U V W end of the motor cable and the U V W end of the drive correspond one by one.	Wire in the correct U V W phase sequence.
2.P0A-08 parameter setting error	◆ Check whether the over-speed fault threshold is less than the maximum motor speed required for actual operation: Over-speed fault threshold=1.2 times the maximum motor speed (P0A-08=0); over-speed fault threshold=P0A-08 (P0A-08 ≠ 0, and P0A-08 <1.2 times the maximum motor speed).	Reset the over-speed fault threshold according to the mechanical requirements.
3. The input command exceeds the overspeed fault threshold	◆ Confirm whether the motor speed corresponding to the input command exceeds the overspeed fault threshold. Position control mode, when the command source is pulse command: Motor speed (rpm)=(Input pulse frequency (HZ))/encoder resolution×electronic gear ratio×60 For this drive, Encoder resolution = 131072(P/r)	Position control mode: When the position command source is a pulse command: under the premise of ensuring the accuracy of the final positioning, reduce the pulse command frequency or reduce the electronic gear ratio when the operating speed allows; Speed control mode: Check the input speed command value or speed limit value (P06-06~P06-09), and confirm that they are all within the over-speed fault threshold; Torque control mode: Set the speed limit threshold within the over speed fault threshold.
4. Motor speed overshoot	◆ Use the drive debugging platform to check whether the "speed feedback" exceeds the	Perform gain adjustment or adjust the mechanical operating conditions.

	overspeed fault threshold.	
5. Servo drive failure	◆ After power on again, the fault still occurs.	Rewire or replace the cable.

22)FU.510: Pulse output overspeed

Production mechanism:

- When using the pulse output function (P05-38=0 or 1), the output pulse frequency exceeds the upper limit of the frequency allowed by the hardware (2MHz).

Reason	Confirmation way	Settlement way
The output pulse frequency exceeds the upper limit of the frequency allowed by the hardware (2MHz)	◆ When P05-38=0 (encoder frequency division output), calculate the output pulse frequency corresponding to the motor speed when the fault occurs, and confirm whether it exceeds the limit. Output pulse frequency (Hz)= $\frac{\text{Motor speed(rpm)}}{60} \times P05 - 17$	Reduce P05-17 (encoder frequency division pulse number), so that in the entire speed range required by the machine, the output pulse frequency is less than the upper limit of the frequency allowed by the hardware.
	◆ When P05-38=1 (pulse command synchronous output), the input pulse frequency exceeds 2MHz or the pulse input pin has interference. Low-speed pulse input pin: Differential input terminals: PULSE+, PULSE-, SIGN+, SIGN-, the maximum pulse frequency is 500kpps. Open collector input terminals: PULLHI, PULSE+, PULSE-, SIGN+, SIGN-, the maximum pulse frequency is 500kpps. High-speed pulse input pin: Differential input terminals: HPULSE+, HPULSE-, HSIGN+, HSIGN-, maximum pulse frequency: 200kpps.	Reduce the input pulse frequency to the upper limit of the frequency allowed by the hardware. Please note: At this time, if the electronic gear ratio is not modified, the motor speed will decrease. If the input pulse frequency itself is high, but does not exceed the upper limit of the frequency allowed by the hardware, anti-interference measures should be taken (pulse input wiring uses twisted-pair shielded wire, set the pin filter parameter P0A-24 or P0A-30) to prevent interference. The pulse is superimposed on the real pulse command, causing a false alarm.

23)FU.602: Angle recognition failed 24)FU.

610: servo drive over speed

Production mechanism:

- The accumulated heat of the drive is too high and reaches the fault threshold 25)FU.620:

Motor over load

Production mechanism:

- The accumulated heat of the motor is too high and reaches the fault threshold

Reason	Confirmation way	Settlement way
1. Motor wiring and encoder wiring are wrong or bad	◆ Compare the correct "wiring diagram" and check the lines between the motor, driver, and encoder.	Connect the cables according to the correct wiring diagram; Preferentially use our standard cables; When using self-made cables, please make and connect them according to the hardware wiring instructions.
2.The load is too heavy, the effective torque of the motor output exceeds the rated torque, and it continues to run for a long time	◆ Confirm the overload characteristics of the motor or drive; ◆ Check whether the drive average load rate (P0B-12) is greater than 100.0% for a long time.	Replace the large-capacity drive and matching motor; or reduce the load, increase the acceleration and deceleration time.
3.Acceleration and deceleration are too frequent or the load inertia is large	◆ Calculate the mechanical inertia ratio or perform inertia identification, check the inertia ratio P08-15; ◆ Confirm the single operation cycle of the servo motor in cyclic operation.	Increase the acceleration and deceleration time in a single operation.
4.Improper gain adjustment or too rigid	◆ Observe whether the motor vibrates or the sound is abnormal during operation.	Re-adjust the gain.

5. Wrong drive or motor model setting	◆ For this series of products: Check the bus motor model P00-05 and the drive model P01-02.	Check the drive nameplate, set the correct drive model (P01-02) and motor model to update to a matching model.
6. The motor is blocked due to mechanical factors, resulting in excessive load during operation	◆ Displayed by the drive debugging platform or panel, confirm the running command and motor speed (P0B-00): Running command in position mode: P0B-13 (Input position command counter) Running command in speed mode: P0B-01 (Speed command) Running command in torque mode: P0B-02 (Internal torque command) Check whether the running command is not 0 and the motor speed is 0 in the corresponding mode.	Exclude mechanical factors.
7. Servo drive failure	◆ After power off, power on again, the fault is still reported.	Replace the servo drive.

Note: ■ The fault can be cleared or the power can be restarted 30s after the overload.

26)FU.625: Brake closed abnormally Production mechanism:

- After the brake protection is turned on, the brake output signal is valid and the input command is zero for the first 100 to 500 ms, the output torque is less than 70% of the gravity load detection value.

Reason	Confirmation way	Settlement way
Motor brake is not open	◆ Confirm whether the motor brake terminal signal is valid and whether the motor brake switch is damaged.	Re-wire according to correct wiring or replace the motor.

27)FU.626: Brake opened abnormally Production mechanism:

- After the brake protection is turned on, the output signal of the brake is invalid, but it is detected that the motor has rotated more than two revolutions at this time.

Reason	Confirmation way	Settlement way
Motor brake opens abnormally	◆ Make sure whether the signal at the motor brake terminal is valid and whether the motor brake switch is damaged.	Re-wire according to correct wiring or replace the motor.

28)FU.630: Locked-rotor motor overheat protection Production mechanism:

- The actual speed of the motor is lower than 10rpm, but the torque command reaches the limit value and the duration reaches the set value of P0A-32.

Reason	Confirmation way	Settlement way
1. Drive U V W output phase loss or phase sequence is connected wrong	◆ Carry out a test run of the motor under no load and check the wiring.	Re-wire according to correct wiring or replace the cable.
2. Drive U V W output disconnection or encoder disconnection	◆ Check cable wire	Re-wire according to correct wiring or replace the cable.
3. The motor is blocked due to mechanical factors	◆ Displayed by the drive debugging platform or panel, confirm the running command and motor speed (P0B-00): Running command in position mode: P0B-13 (Input position command counter) Running command in speed mode: P0B-01 (Speed command) In torque mode	Troubleshoot mechanical factors.

	Run command: P0B-02 (Internal torque command) Check whether the running command is not 0 and the motor speed is 0 in the corresponding mode.	
--	--	--

29)FU.650: Radiator overheated Prod

uction mechanism:

- The temperature of the drive power module is higher than the over-temperature protection point.

Reason	Confirmation way	Settlement way
1. The ambient temperature is too high	◆ Measure the ambient temperature	Improve the cooling conditions of the servo drive and lower the ambient temperature.
2.After overload, resetthe overload fault by turning off the power, and repeat it many times	◆ Check the fault record (set P0B-33, check P0B-34), whether there is an overload fault or warning (FU.610, FU.620, FU.630, FU.650, FU.909, FU.920, FU.922).	Change the fault reset method,wait 30s after overload, and then reset. Increase the drive and motor capacity, increase the acceleration and deceleration time, and reduce the load.
3. The fan is broken	◆ Whether the fan is running during operation.	Replace the servo drive.
4. The installation direction of the servo drive and the interval with other servo drives are unreasonable	◆ Confirm whether the installation of the servo drive is reasonable.	Install according to the installation standard of the servo drive.
5. Servo drive failure	◆ The fault will still be reported after 5 minutes of power failure.	Replace the servo drive.

30)FU.731: Encoder battery failure

Production mechanism:

- The encoder battery voltage of the multi-turn absolute encoder is too low or the battery is not connected.

Reason	Confirmation way	Settlement way
During power failure, the battery was not connected	◆ Confirm whether it is connected during power failure	Set P0D-20=1 to clear the fault
Encoder battery voltage is too low	◆ Measure battery voltage	Replace with a new battery that matches the voltage

Note: ■ This fault only occurs when the multi-turn absolute position function is enabled (P0201=1 or 2).

31)FU.733: Encoder multi-turn counting error.Producti

on mechanism:

- Encoder multi-turn counting error.

Reason	Confirmationway	Settlement way
Encoder failure	◆ Setting P0D-20=1 Clear the fault, FU.733 still occurs after power-on again	Replace the motor

32)FU.735: Encoder multi-turn counting overflow Production

mechanism:

- Detection of encoder multi-turn counting overflow.

Reason	Confirmation way	Settlement way
When P02-01=1, detect encoder multi-turn counting overflow	-	Set P0D-20=1 to clear the fault and power on again

33)FU.740: Encoder interference Produ

ction mechanism:

- The Z signal of the encoder is interfered, causing the electrical angle corresponding to the Z signal to change too much.

Reason	Confirmation way	Settlement way
1. Encoder wiring error	◆ Check the encoder wiring.	Re-wiring according to the correct wiring diagram
2. The encoder cable is loose	◆ Check whether the on-site vibration is too large, causing the encoder cable to loosen, or even vibration to the encoder.	Re-wire and ensure that the encoder terminal is tightly connected.
3. Encoder Z signal is interfered	<p>◆ Check the wiring on site: Whether there is interference from large-scale equipment around, or whether there are multiple sources of interference such as multiple power supply frequency conversion equipment in the cabinet.</p> <p>◆ Put the servo in the "Rdy" state, manually rotate the motor shaft counterclockwise to monitor whether P0B-10 (electrical angle) increases or decreases smoothly, and one circle corresponds to 5 0-360°. (Refer to Z series motor, if it is X series motor, 4 0-360°).</p> <p>If there is an abnormal sudden change in P0B-10 during rotation, the encoder itself has a serious problem.</p> <p>If there is no alarm during rotation, but the alarm occurs during servo operation, the possibility of interference is high.</p>	<p>The cables are given priority to use our standard cables; If the wiring is not standard, check whether the cable meets the specifications and whether it uses twisted-pair shielded wire. Separate the strong and weak currents as much as possible, and do not bundle the motor cables and encoder cables. The ground contact between the motor and the driver is good.</p> <p>Check whether the plugs at both ends of the encoder are in good contact, and whether the needles are retracted.</p>
4. Encoder failure	<p>◆ Replace the encoder cable that can be used normally. If the failure no longer occurs after replacement, the original encoder cable is damaged.</p> <p>◆ Put the motor at the same position, power on several times and check P0B-10, the electrical angle deviation should be within $\pm 30^\circ$.</p>	<p>Replace the encoder cable that can be used normally. If not, the encoder itself has a serious problem and the servo motor needs to be replaced.</p>

34)FU.834: AD Sampling overvoltage fault Production mechanism:

- AI the sampled value is greater than 11.5V.

Reason	Confirmation way	Settlement way
1. AI channel input voltage is too high	◆ Measure the input voltage of the AI channel and check whether the actual sampled voltage (P0B-21 or P0B-22) is greater than 11.5V	Check the sampled voltage while adjusting the input voltage until the sampled voltage does not exceed 11.5V.
2. AI channel wiring error or interference	◆ Refer to the correct wiring diagram to check the AI channel wiring	<p>Re-wiring with twisted-pair shielded wire to shorten the line length</p> <p>Increase the AI channel filter time constant: AI1 filter time constant: P03-51 AI2 filter time constant: P03-56</p>

35)FU.835: High-precision AD sampling failure Production mechanism:

- High-precision AD circuit is interfered

Reason	Confirmation way	Settlement way
1. High-precision AI channel wiring has interference	◆ Refer to the correct wiring diagram to check the AI channel wiring	Re-wiring with twisted-pair shielded wire to shorten the line length

36)FU.A33: Encoder data is abnormal

Production mechanism:

- The internal parameters of the encoder are abnormal.

Reason	Confirmation way	Settlement way
1. The cable of the bus-type incremental encoder is broken or loose	◆ Check cable wire	Check whether the encoder cable is incorrectly connected, or if the wire is broken or the contact is poor. If the motor cable and the encoder cable are bundled together, please separate the wiring.
2. The parameter reading and writing of the bus type incremental encoder is abnormal	◆ If the fault is still reported after turning on the power several times, the encoder has a fault.	Replace the motor

37)FU.B00: Position deviation is too large

Production mechanism:

- In position control mode, the position deviation is greater than the set value of P0A-10.

Reason	Confirmation way	Settlement way
1. Drive U V W output phase loss or phase sequence is connected wrong	◆ Carry out a test run of the motor under no load and check the wiring.	Re-wire according to correct wiring or replace the cable.
2. Drive U V W output disconnection or encoder disconnection	◆ Check cable wire	Re-wiring, the servo motor power cable and the drive power cable UVW must correspond one-to-one. If necessary, replace with a new cable and ensure its reliable connection.
3. The motor is blocked due to mechanical factors	◆ Displayed by the drive debugging platform or panel, confirm the running command and motor speed (P0B-00): Running command in position mode: P0B-13 (Input position command counter) Running command in speed mode: P0B-01 (speed command) Running command in torque mode: P0B-02 (internal torque command) Check whether the running command is not 0 and the motor speed is 0 in the corresponding mode.	Troubleshoot mechanical factors.
4. Servo drive gain is low	◆ Check the position loop gain and speed loop gain of the servo drive: The first gain: P08-00~P08-02 Second gain: P08-03~P08-05	Perform manual gain adjustment or automatic gain adjustment.
5. High input pulse frequency	◆ When the position command source is pulse command, whether the input pulse frequency is too high. ◆ The acceleration /deceleration time is 0 or too small.	Reduce the position command frequency or reduce the electronic gear ratio. When using the host computer to output position pulses, a certain acceleration time can be set in the host computer; If the host computer cannot set the acceleration and deceleration time, increase the position command smoothing parameters P05-04 and P05-06.
6. Relative to the operating conditions, the fault value (P0A-10) is too small	◆ Confirm whether the position deviation fault value (P0A-10) is set too small.	Increase the set value of P0A-10.
7. Servo drive /servo motor error	◆ Monitor the running waveform through the oscilloscope function of the drive debugging platform: Position command, position feedback, speed command, torque command.	If the position command is not zero and the position feedback is always zero, please replace the servo driver/motor.

38)FU.B01: Pulse input abnormal

Production mechanism:

- The input pulse frequency is greater than the maximum position pulse frequency (P0A-09).

Reason	Confirmation way	Settlement way
1. The input pulse frequency is greater than the set maximum position pulse frequency (P0A-09)	◆ Check whether P0A-09 (maximum position pulse frequency) is less than the maximum input pulse frequency required when the machine is running normally.	Reset P0A-09 according to the maximum position pulse frequency required during normal operation of the machine. If the output pulse frequency of the upper computer is greater than 2MHz, the output pulse frequency of the upper computer must be reduced.
2. Input pulse interference	<p>◆ First, use the oscilloscope function of the drive debugging platform software to check whether there is a sudden increase in the position command, or check whether the servo drive input position command counter (P0B-13) is greater than the number of pulses output by the host computer.</p> <p>◆ Then, check the grounding of the circuit.</p>	<p>First of all, the pulse input cable must use twisted-pair shielded cable and be routed separately from the drive power cable.</p> <p>Secondly, use the low-speed pulse input port (P05-01=0), when the differential input is selected, the “ground” of the host computer must be reliably connected to the “GND” of the driver;</p> <p>When selecting open-collector input, the “ground” of the host computer must be reliably connected to the “COM” of the driver;</p> <p>Use high-speed pulse input port (P05-01=1), only differential input can be used, and the “ground” of the host computer must be reliably connected to the “GND” of the driver.</p> <p>Finally, according to the selected hardware input terminal, increase the pin filter time P0A-24 or P0A-30 of the pulse input terminal.</p>

39)FU.B02: Full closed loop position deviation is too large

Production mechanism:

- The absolute value of the full closed loop position deviation exceeds P0F-08 (full closed loop position deviation too large threshold).

Reason	Confirmation way	Settlement way
1. Drive U V W output phase loss or phase sequence is connected wrong	◆ Carry out a test run of the motor under no load and check the wiring.	Re-wire according to correct wiring or replace the cable.
2. Drive U V W output disconnection or internal/external encoder disconnection	◆ Check cable wire	Re-wiring, the servo motor power cable and the drive power cable UVW must correspond one-to-one. If necessary, replace with a new cable and ensure its reliable connection.
3. The motor is blocked due to mechanical factors	<p>◆ Displayed by the drive debugging platform panel, confirm the running command and motor speed (P0B-00):</p> <p>Running command in position mode: P0B-13 (Input position command counter)</p> <p>Running command in speed mode: P0B-01 (Speed command)</p> <p>Running command in torque mode: P0B-02 (Internal torque command)</p> <p>Check whether the running command is not 0 and the motor speed is 0 in the corresponding mode.</p>	Troubleshoot mechanical factors.

4. Servo drive gain is low	<ul style="list-style-type: none"> ◆ Check the position loop gain and speed loop gain of the servo drive: The first gain: P08-00~P08-02 Second gain: P08-03~P08-05 	Perform manual gain adjustment or automatic gain adjustment
5. High input pulse frequency	<ul style="list-style-type: none"> ◆ When the position command source is pulse command, whether the input pulse frequency is too high. ◆ The acceleration/deceleration time is 0 or too small. 	Reduce the position command frequency or reduce the electronic gear ratio. When using the host computer to output position pulses, a certain acceleration time can be set in the host computer; If the host computer cannot set the acceleration and deceleration time, increase the position command smoothing parameters P05-04 and P05-06.
6. Relative to operating conditions, the fault value (P0F-08) is too small	Confirm the fault threshold of the full closed loop position deviation is too large (P0F-08) Is the setting too small	Increase P0F-08 setting value
7. Servo drive / Motor failure	<ul style="list-style-type: none"> ◆ Monitor the running waveform through the oscilloscope function of the drive debugging platform: Position command, position feedback, speed command, torque command. 	If the position command is not zero and the position feedback is always zero, please replace the servo drive/motor.

40)FU.B03: Electronic gear setting over run Product

ion mechanism:

- Any group of electronic gear ratio exceeds the limit value:
($0.001 \times \text{encoder resolution} / 10000$, $4000 \times \text{encoder resolution} / 10000$).

Reason	Confirmation way	Settlement way
The electronic gear ratio setting value exceeds the above range	<ul style="list-style-type: none"> ◆ If P05-02=0, determine the ratio of parameters P05-07/P05-09 and P05-11/P05-13 ◆ If P05-02>0, confirm: encoder resolution / ratio of P05-02, P05-07/P05-09, P05-11/P05-13 	Encoder resolution / P05-02, P05-07/P05-09, P05-11/P05-13 The ratio is set within the above range.
Parameter change order problem	<ul style="list-style-type: none"> ◆ Change related parameters of electronic gear ratio: For P05-02, P05-07/P05-09, P05-11/P05-13, the electronic gear ratio exceeds the limit due to the unreasonable change sequence during the transition process of calculating the electronic gear ratio. 	Use the fault reset function or re-power on.

41)FU.B04: Full closed loop function parameter setting error

Production mechanism:

- When the full closed loop function is used and the position command source is an internal position command, the internal and external loop switching function is used.

Reason	Confirmation way	Settlement way
In the fully closed loop position mode, the position command source is the internal position command, but the internal and external loop switching mode is used	<ul style="list-style-type: none"> ◆ Check if P0F-00 is 2; ◆ Confirm whether the source of position command is internal position command: multi-segment position command, interrupt fixed length function. 	When the full-closed loop function is used and the position command source is an internal position command, only the external encoder feedback mode can be used, that is, P0F-00 can only be 1.

42)FU.D03: CAN Communication connection is interrupted Production mechanism:

- CAN Communication timed out.

Reason	Confirmation way	Settlement way
CAN Communication connection interrupted: slave station dropped	<ul style="list-style-type: none"> ◆ Check the status of the main station PLC CAN communication card light: The ERR light of the master PLC flashes at a frequency of 1 Hz, and some of the ERR lights of the slave PLCs are on (when using the PLC background software, you can monitor D78xx in the component monitoring table of the master. xx represents the station number, decimal, part The corresponding D78xx of the configured station is 5, which means that the slave station is faulty) 	<p>Check the connection of the communication cable between the slave station with the ERR light on and the master station; Check the communication baud rate P0C-08 of the slave station with the ERR light on and adjust it to be consistent with the master station.</p>
CAN Communication connection is interrupted: the master station drops	<ul style="list-style-type: none"> ◆ Check the status of the main station PLC CAN communication card light: The ERR lights of all slave PLCs are always on (when using the PLC background software, D78xx can be monitored in the component monitoring table of the master station, xx represents the station number, in decimal, all D78xx corresponding to all configured stations are all 5 indicating that the master station has occurred malfunction). 	<p>Check the cable connection of the master station.</p>

7.2.3 How to deal with warnings

1)FU.110: Frequency division pulse output setting failure

Production mechanism:

- When using the encoder frequency division output function (P05-38=0), the set encoder frequency division pulse number does not meet the threshold determined by the encoder specification

Reason	Confirmation way	Settlement way
Encoder frequency division pulse number does not meet the range	<ul style="list-style-type: none"> ◆ Incremental code disc: the frequency division pulse number of the encoder cannot exceed the resolution of the encoder; 17bit bus type incremental encoder, resolution 131072(P/r); 23bit bus type incremental encoder, resolution 8388608(P/r); ◆ Absolute code disc: The number of pulses of the encoder frequency division cannot exceed 1/4 of the encoder resolution. 	<p>Reset the encoder frequency division pulse number (P05-17) so that it meets the specified range.</p>

2)FU.601: Back to origin timeout failure

Production mechanism:

- When using the origin return function (P05-30=1~5), the origin is not found within the time set by P05-35.

Reason	Confirmation way	Settlement way
1. Origin switch failure	<ul style="list-style-type: none"> ◆ When returning to origin, it is always searching at high speed without low speed searching process. ◆ After the origin return high-speed search, it has been in the reverse low-speed search process. 	<p>If you are using hardware DI, confirm that the DI function 31 has been set in group P03, and then check the DI terminal wiring. When the DI terminal logic is changed manually, monitor whether the driver receives the corresponding DI level change through P0B-03. If not, It means that the DI switch wiring is wrong; if it is, it means there is an error in the home return operation. Please refer to section 6.2.8 to operate this function correctly. If you are using virtual DI, refer to 10.4 to check whether the VDI use process is correct</p>

2. Limit the time to find the origin is too short	◆ Check whether the time set in P05-35 is too short	Increase P05-35
3. The speed of the high-speed search origin switch signal is too low	◆ Check the distance between the home position and the origin switch to determine whether the speed value set by P05-32 is too small, resulting in too long time to find the origin switch	Increase P05-32

3)FU.730: Encoder battery warning

Production mechanism:

- The encoder battery voltage of the multi-turn absolute encoder is too low or the battery is not connected.

Reason	Confirmation way	Settlement way
During power failure, the battery was not connected	◆ Confirm whether it is connected during power failure	Replace with a new battery that matches the voltage
Encoder battery voltage is too low	◆ Measure battery voltage	

Notes: ■ This fault only occurs when the multi-turn absolute position function is enabled (P0201=1 or 2).

4)FU.831: AI Zero drift is too large

Production mechanism:

- AI (includes AI1 and AI2) when the terminal input voltage is 0V, the voltage sampled by the driver is greater than 500mV.

Reason	Confirmation way	Settlement way
1. Wiring error or interference	◆ Check the wiring with reference to the correct wiring diagram.	Use twisted-pair shielded wire to re-wire to shorten the line length. Increase the AI channel filter time constant: AI1 filter time constant: P03-51 AI2 filter time constant: P03-56
2. Servo drive error	◆ Remove the external wiring of the AI terminal (input is 0), and check whether the AI sampling value of group P0B exceeds 500mV.	If it exceeds, replace the drive.

5)FU.900: DI Urgent brake

Production mechanism:

- DI function 34 (FunIN.34: brake, Emergency) The corresponding DI terminal logic is valid (including hardware DI and virtual DI).

Reason	Confirmation way	Settlement way
DI function 34: brake, Is triggered	◆ Check DI function 34: Emergency Stop brake, and whether its corresponding DI terminal logic is set to valid.	Check the operating mode, and on the premise of confirming safety, release the DI brake valid signal.

6)FU.909: Motor overload warning

Production mechanism:

- 60Z series 200W and 400W motor, the accumulated heat of the motor is too high and reaches the warning value.

Reason	Confirmation way	Settlement way
1. Wrong or bad motor wiring and encoder wiring	◆ Compare the correct wiring diagram and check the wiring between the motor, driver, and encoder.	Connect the cables according to the correct wiring diagram; Preferentially use our standard cables; When using self-made cables, please make and connect them according to the hardware wiring instructions.
2. The load is too heavy, the effective torque of the motor output exceeds the rated torque, and it continues to run for a long time	◆ Confirm the overload characteristics of the motor or drive; ◆ Check whether the drive average load rate (P0B-12) is greater than 100.0% for a long time.	Replace the large-capacity drive and matching motor; Or reduce the load and increase the acceleration and deceleration time.

3. Acceleration and deceleration are too frequent or the load inertia is too large	<ul style="list-style-type: none"> ◆ Check the mechanical inertia ratio or perform inertia identification, and check the inertia ratio P08-15. ◆ Confirm the single operation cycle of the servo motor in cyclic operation. 	Increase the acceleration and deceleration time.
4. Improper gain adjustment or excessive rigidity	<ul style="list-style-type: none"> ◆ Observe whether the motor vibrates or the sound is abnormal during operation. 	Re-adjust the gain.
5. Wrong drive or motor model setting	<ul style="list-style-type: none"> ◆ For this series of products: Check the bus motor model P00-05 and the drive model P01-02. 	Check the drive nameplate, set the correct drive model (P01-02) and update the motor model to a matching model.
6. The motor is blocked due to mechanical factors, resulting in excessive load during operation	<ul style="list-style-type: none"> ◆ Use the drive debugging platform or panel to view the running command and motor speed (P0B-00): Running command in position mode: P0B-13 (Input position command counter) Running command in speed mode: P0B-01 (Speed command) Running command in torque mode: P0B-02 (Internal torque command) Check whether the running command is not 0 or very large in the corresponding mode, and the motor speed is 0. 	Exclude mechanical factors.
7. Servo drive failure	<ul style="list-style-type: none"> ◆ After power off, power on again. 	Please replace the servo drive if the fault is reported after power-on again.

7)FU.920 :Braking resistor overload alarm

Production mechanism:

- The cumulative heat of the braking resistor is greater than the set value

Reason	Confirmation way	Settlement way
1. The connection of the external brake resistor is bad, dropped or broken	<ul style="list-style-type: none"> ◆ Remove the external braking resistor, and directly measure whether the resistance value is "∞" (infinity); ◆ Measure whether the resistance between B1+ and B2 is "∞" (infinity). 	Replace with a new external braking resistor . After the measured resistance value is consistent with the nominal value, connect it between B1/⊕ and B2.
		Choose a good cable and connect both ends of the external braking resistor between B1/⊕ and B2.
2. When using the built-in braking resistor, the cable between the power terminals B2 and B3 is short or disconnected	<ul style="list-style-type: none"> ◆ Measure whether the resistance between B2 and B3 is "∞" (infinity). 	Connect B2 and B3 directly with a good cable.
3. When using an external braking resistor, the selection of P02-25 (brake resistor setting) is wrong	<ul style="list-style-type: none"> ◆ View the parameter value of P02-25; ◆ Measure the resistance value of the external resistor between B1+ and B2 actually selected, and compare it with the brake resistor specification table to see if it is too large; ◆ Check whether the parameter value of P02-27 is greater than the resistance value of the external resistance between B1+ and B2 actually selected. 	Setting correct P02-25: P02-25=1 (use external resistor, natural cooling)P02-25=2 (Use external resistor, forced air cooling)
4. When using an external braking resistor, the actually selected external braking resistor resistance is too large		Refer to the braking resistor specification table and select the resistor with the proper resistance value correctly.
5. P02-27 (resistance value of external braking resistor) is greater than the actual resistance value of external braking resistor		Set P02-27 to be consistent with the actual selection of external resistance.

6. The input voltage of the main circuit exceeds the specification range	<ul style="list-style-type: none"> ◆ Measure whether the input voltage of the main circuit cable driver side meets the following specifications: 220V drive: Effective value: 220V~240V Allowable deviation: -10%~+10% (198V~264V) 	Adjust or replace the power supply according to the specifications on the left.
7. The load moment of inertia ratio is too large	<ul style="list-style-type: none"> ◆ Identify the moment of inertia; or manually calculate the total moment of inertia according to the mechanical parameters; ◆ Whether the actual load inertia ratio exceeds 30. 	Select a large-capacity external braking resistor, and set P02-26 to be consistent with the actual value; Use large-capacity servo driver; If allowed, reduce the load; If allowed, increase the acceleration and deceleration time; If allowed, increase the motor running cycle.
8. The motor speed is too high, the deceleration process is not completed within the set deceleration time, and it is in continuous deceleration state during periodic movement	<ul style="list-style-type: none"> ◆ View the speed curve of the motor during periodic movement, and check whether the motor is decelerating for a long time. 	
9. The capacity of the servo drive or the capacity of the braking resistor is insufficient	<ul style="list-style-type: none"> ◆ Check the single cycle speed curve of the motor and calculate whether the maximum braking energy can be completely absorbed. 	
10. Servo drive failure	-	Replace the drive.

8)FU.922: External braking resistor is too small

Production mechanism:

- P02-27(External braking resistor)< P02-21(The drive allows the minimum value of external braking resistor)

Reason	Confirmation way	Settlement way
When using an external braking resistor (P02-25=1 or 2), the resistance of the external braking resistor is less than the minimum value allowed by the drive	<ul style="list-style-type: none"> ◆ Measure the resistance of the external braking resistor between B1+ and B2 to confirm whether it is less than P02-21. 	If it is, replace it with an external braking resistor that matches the driver. After setting P02-27 to the selected resistance value, connect both ends of the resistor between B1+ and B2; If not, set P02-27 to the actual resistance value of the external braking resistor.

9)FU.939: Motor power line is broken

Production mechanism:

- The actual phase current of the motor is less than 10% of the rated current, and the actual speed is low, but the internal torque command is large.

Reason	Confirmation way	Settlement way
Motor power line is broken	<ul style="list-style-type: none"> ◆ Check whether the phase current effective value (P0B-24) and the internal torque command (P0B-02) are more than 5 times different, and the actual motor speed (P0B-00) is less than 1/4 of the motor rated speed. 	Check the wiring of the motor power cable, reconnect it, and replace the cable if necessary.

10)FU.941: Change parameters need to be re-powered to take effect

Production mechanism:

- When the "effective time" of the function code attribute of the servo drive is "power on again", after the parameter value of the function code is changed, the drive reminds the user to power on again.

Reason	Confirmation way	Settlement way
Change the function code that will take effect after powering on again	<ul style="list-style-type: none"> ◆ Confirm whether the function code whose "effective time" is "re-power on" is changed. 	Power on again.

11)FU.942: Frequent parameter storage

Production mechanism:

- The number of function codes modified at the same time exceeds 200

Reason	Confirmation way	Settlement way
Very frequently and a large number of function code parameters are modified and stored in EEPROM (P0C-13=1)	Check whether the host computer system frequently and quickly modify the function code.	Check the operating mode. For parameters that do not need to be stored in the EEPROM, set P0C-13 to 0 before the host computer writes.

12)FU.950: Forwardovertravel warning

Production mechanism:

- DI function 14(FunIN.14: P-OT, Forward overtravel switch) The corresponding DI terminal logic is valid.

Reason	Confirmation way	Settlement way
DI function 14: Prohibit forward drive, terminal logic is valid	<ul style="list-style-type: none"> ◆ Check whether the DI terminal of group P03 is set to DI function 14; ◆ Check whether the DI terminal logic of the corresponding bit of the input signal monitoring (P0B-03) is valid. 	Check the operating mode, and on the premise of ensuring safety, give a negative command or rotate the motor to make the "positive overtravel switch" terminal logic invalid.

13)FU.952: Reverse overtravel warning

Production mechanism:

- DI function 15(FunIN.15: N-OT, Reverse overtravel switch) the corresponding DI terminal logic is valid.

Reason	Confirmation way	Settlement way
DI function 15: Reverse drive is prohibited, and the terminal logic is valid.	<ul style="list-style-type: none"> ◆ Check whether DI function 15 is set for the DI terminal of group P03; ◆ Check whether the DI terminal logic of the corresponding bit of the input signal monitoring (P0B-03) is valid. 	Check the operating mode, and if it is safe, give a negative command or rotate the motor to make the "reverse overtravel switch" terminal logic invalid.

14)FU.980: Encoder internal fault

Production mechanism:

- The encoder algorithm is incorrect.

Reason	Confirmation way	Settlement way
Encoder internal fault	<ul style="list-style-type: none"> ◆ When the fault is reported after turning on the power several times, the encoder has a fault. 	Replace the drive.

15)FU.994: CANAddress conflict

Reason	Confirmation way	Settlement way
CANlink Address conflict	<ul style="list-style-type: none"> ◆ Confirm whether there is duplicate allocation among slave stations P0C-00 	Assign each slave address to ensure that P0C-00 is not repeated.

7.2.4 Inner fault

Please contact our technicians when the following failures occur.

FU.602: Angle recognition failed;

FU.220: phase sequence error

FU.A40: Parameter identification failed;

FU.111: Servo internal parameters are abnormal

Quality Assurance and Product Warranty Regulation

1. This regulation is a protocol between the manufacturer who produces the product (hereinafter referred to as manufacturer) and the user who uses the product (hereinafter referred to as user). Any user who purchases and uses the product provided by the manufacturer is regarded as knowing and agreeing with the protocol.

About Product Quality and Warranty

1.1 The manufacturer provides complete and available product.

1.2 The manufacturer is not responsible for the problems and losses due to the following reasons:

1) All operations not according to the specification and incorrect operation and installation; problems and losses caused by self-maintenance which is not permitted by the manufacturer.

2) Expired for the warranty period locked in this regulation.

3) Problems and losses due to artificial or natural irresistible reasons after the purchase.

4) Problems and losses due to the installation and the use of the product not under product required environment by the user.

2. Contents of Warranty on Product Made by Manufacturer

2.1 For domestic use:

1) Change, repair and return are guaranteed within 1 week since the delivery.

2) Change and repair are guaranteed within 1 month since the delivery.

3) Repair is guaranteed within 12 months since the delivery.

4) For those expired for the warranty period or warranty scope, we have to charge the cost.

2.2 For product exported over seas, repair is guaranteed within 3 months since the delivery.

2.3 The user can enjoy life time paid services when ever and wherever using products of our brand.

2.4 All sales organizations, productive facilities and agencies of our company across the country can provide after-sale services for our product.

2.5 For products out of order, our company has the right to authorize others to be responsible for affairs of warranty, etc.

3. Rights Reserved by Manufacturer and Immunity Affairs

3.1 The manufacture is not liable for compensation for all direct and indirect problems and losses caused by the installation and the use of the user of our product.

3.2 All rights for the product are reserved by the manufacturer. The product may be changed without further notification. Please make the object as the standard.

3.3 The manufacturer has the final power of interpretation on the product.

3.4 The regulations are available to other products of the manufacturer.

3.5 The terms above will be executed since June 21th, 2022.