

# User's Manual

For

## ESS11-01

Integrated Stepper Motor

©2020 All Rights Reserved Attention: Please read this manual carefully before using the Motor!



## ESS11-01

### Integrated Stepper Motor

#### Features

- Using a new 32-bit motor control, dedicated DSP chip
- Pulse input frequency up to 200 KHz
- Small torque attenuation, speed up to 3000 RPM
- Built-in alarm output, for monitoring and controlling
- Intelligently adjust current, reduce vibration, noise and this can increase efficiency by 35%
- Pulse/direction (PU / DR) control
- Default microstep resolution: 1000
- Voltage range: DC24V
- Over-voltage, under-voltage and over-current protection
- Excellent high speed performance and rigidity, combined with advantages of servo motor and stepper motor
- Drive and motor integrated, simple wiring

#### Input signal waveform sequence diagram

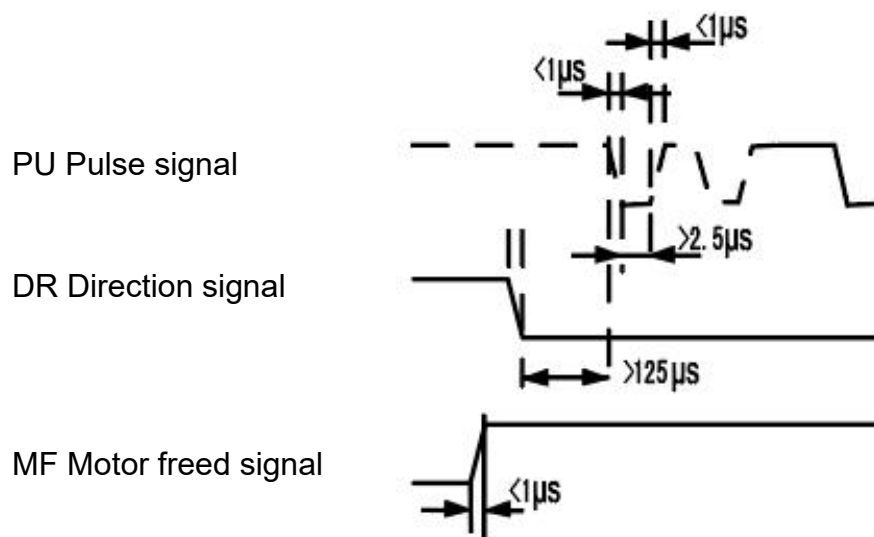

## Installation size (unit: mm)

### Front view

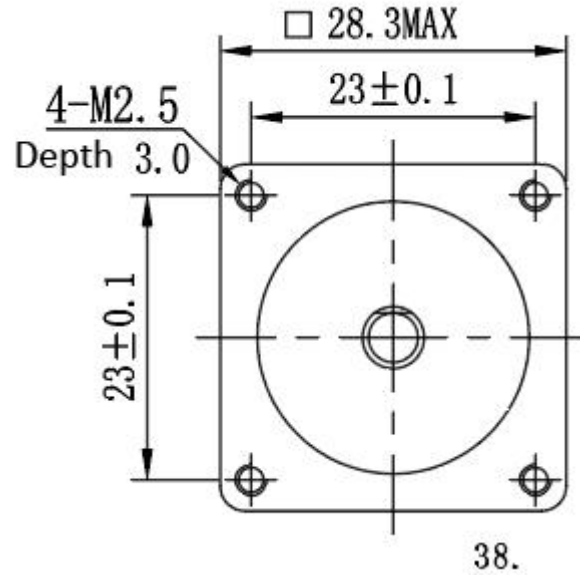

### Side view

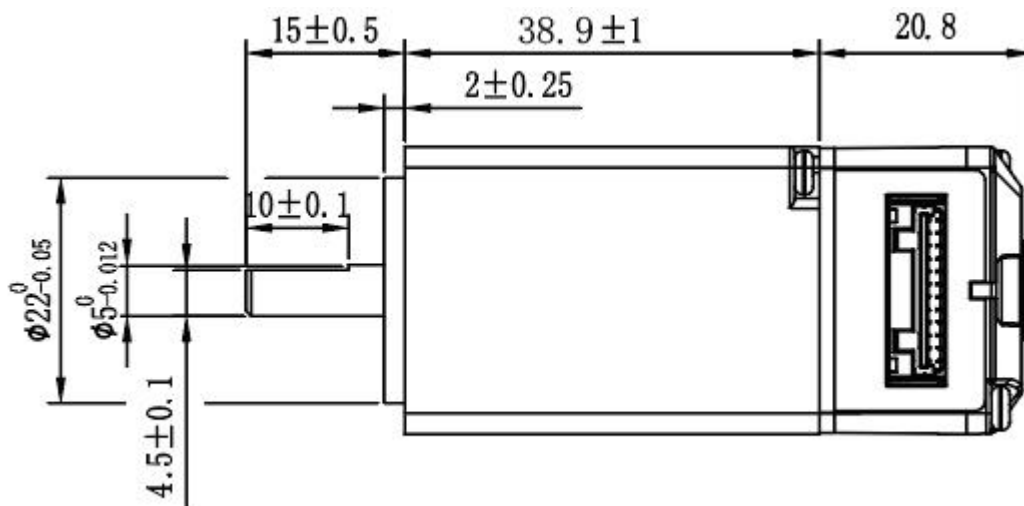

## Indicator light description

Color	Symbol	Specification
RED	RUN / ALM	When the power is on, the indicator is always on;
		In case of over-current, the indicator light flashes once and circulates; In case of over-voltage, the indicator light flashes twice and circulates; In case of under-voltage, the indicator light flashes three times and circulates; In case of out of tolerance, the indicator light flashes five times and circulates;

## Input/output ports

Function	Specification	Remark
DC+	Supply voltage	DC: 24V
GND	Ground	
PU+	Pulse input signal+	Signal power supply: 5V ~ 24V, >5V, add a current-limiting resistance
PU-	Pulse input signal-	
DR+	Direction input signal+	
DR-	Direction input signal+	
MF+	Motor freed signal+	
MF-	Motor freed signal-	
--	NC	NC
--		
--		
--		





## Electrical Specifications

Parameters	ESS11-01			
	MIN	TYP	MAX	UNIT
Output Current	0	-	1.2	A
Input Voltage	-	24	-	Vdc
Logic Signal Current	7	10	16	mA
Logic Signal Voltage	-	5	24	V
Pulse Input Frequency	0	-	200	kHz
Isolation Resistance	100	-	-	MΩ

## Others Specifications

Parameters	UNIT	ESS11-01
NO. of Phase	--	2
Step Angle	°	1.8
Motor length	mm	38.9
Holding Torque	N.m	0.074
Rated Current	A	1.0
Rotor Inertia	g.cm <sup>2</sup>	10
Insulation Class	--	B
Operating Temperature	°c	0 ~ 55
Weight	Kg	0.18

## Fault diagnosis

Fault code	Fault Information	RUN/ALM Output	Reset
Err1:0x01	Over-current / short circuit		Power down reset
Err2:0x02	Over-voltage		Lock machine /auto recoery
Err3:0x03	Under-voltage		Lock machine /auto recoery
Err5:0x05	position following error		Power down reset

## Operating Environment

Cooling	Fin cooling	
<b>Working Environment</b>	Workplace	Stay away from other heating sources, Avoid dust, oil fog , corrosive and combustibile gases and Strong vibration site
	Temperature	0°c ~ 50°c
	Humidity	40-90%RH(no condensation, no frosting)
	Vibration	10 ~ 55Hz/0.15mm
<b>Storage Temperature</b>	-20°c ~ +80°c	
 Warning: Motor installation, do not knock motor back cover, so as to avoid damage encoder.		

## Control signal connection(Input signal)

**+5V: R1=0, R2=0**

**+12V: R1=510Ω, R2=820Ω**

**+24V:R1=1.2KΩ,R2=1.8KΩ**

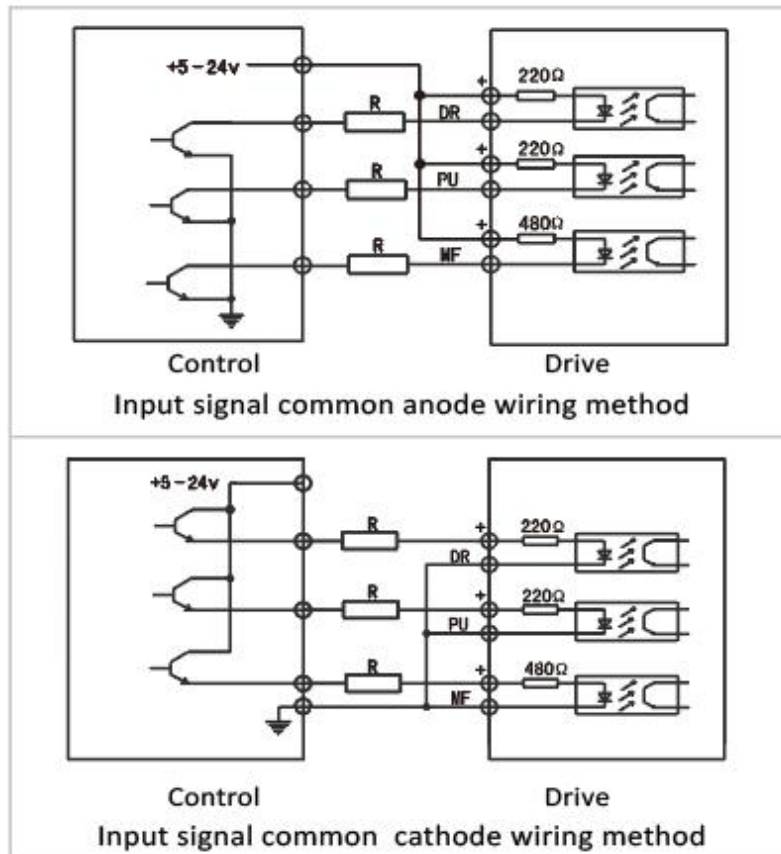

## Control signal connection(Output signal)

