



www.oyostepper.com

H1 Series Inverter User Manual



Preface

Thanks for using the H1 series compact vector inverter produced H1 series inverter is a new generation of adaptive vector inverter independently developed by our company based on the industry application requirements of high stability, small size and easy debugging. This product has V/F control, speed sensorless vector control, etc., suitable for asynchronous motors, permanent magnet synchronous motors, single-phase motors.

H1 series inverter have compact structure, convenient and flexible installation, reasonable heat dissipation design to ensure product reliability, rich keyboards and multi-function cards to choose, flexible functions, free programming, and can meet the needs of different industries.

The manual provides users with relevant precautions and guidance for the selection, installation, parameter setting, on-site debugging, fault diagnosis and daily maintenance. In order to ensure that the inverter can be used correctly, please read this manual carefully before installing it and keep it in a safe place for later use.



www.oyostepper.com

First time to use:

For the first time to use, please read this manual carefully. If you have any doubts about some functions and performance, please contact our technical staff for help.

The scope of application of this manual:

This manual applies to the H1 series of products produced by our company
Version No.: 2021.V1.0

Attentions:

- ◆ Please power off when wiring.
- ◆ Electronic components inside AC drive are especially sensitive to static electricity, do not put anything into internal of AC drive. And do not touch main circuit board.
- ◆ After power cut, if indicator is still lamp, it still have high voltage in AC drive. It is very dangerous, please do not touch internal circuit and components
- ◆ Please ensure the grounding terminals of AC drive (⊥) is grounded correctly.
- ◆ Never connect input power supply with output terminal U, V, W of AC drive.

Contents

| | |
|--|----|
| Contents | 1 |
| Safety Precautions | 4 |
| Warning..... | 4 |
| Notes..... | 4 |
| Operation precautions..... | 5 |
| H1 series nameplate | 7 |
| H1 series specification | 7 |
| CHAPTER 1 - Installation | 8 |
| 1.1 Installation prevention | 8 |
| CHAPTER 2 - Basic configuration | 9 |
| 2.1 Peripheral device connection | 9 |
| 2.2 List of main circuit applicable devices and their electrical specifications..... | 9 |
| CHAPTER 3 - Wiring..... | 10 |
| 3.1 Main circuit and function card | 10 |
| 3.2 Power terminal wiring instructions..... | 10 |
| 3.3 Main circuit terminal description | 11 |
| 3.4 Function card configuration table | 11 |
| CHAPTER 4 - Keyboard | 12 |
| 4.1 Keyboard features..... | 12 |
| 4.2 Keyboard operation..... | 13 |
| 4.3 Character display | 13 |
| CHAPTER 5 - Quick get start..... | 14 |
| CHAPTER 6 - Function parameter list | 18 |
| 6.1 Group 01 parameters: System parameters..... | 38 |
| 6.2 Group 02 parameters: Set channel | 42 |
| 6.3 Group 03 parameters: Input and output..... | 49 |
| 6.4 Group 04 parameters: PID control | 56 |
| 6.5 Group 05 parameters: System control | 59 |
| 6.6 Group 06 parameters: Motor model | 64 |
| 6.7 Group 07 parameters: Control algorithm..... | 65 |
| 6.8 Group 09 parameters: System protect | 67 |
| 6.9 Group 10 parameters: System status..... | 67 |
| 6.10 Group 11 parameters: Fault record..... | 71 |
| 6.11 Group 12 parameters: Free parameter | 72 |
| 6.12 Group 13 parameters: Function output..... | 72 |
| 6.13 Group 14 parameters: Encoder..... | 74 |
| 6.14 Group 16 parameters: Logic unit..... | 74 |
| 6.15 Group 17 parameters: Mathematical operations..... | 79 |
| 6.16 Group 18 parameters: Timing control..... | 84 |

| | |
|--|-----|
| CHAPTER 7 - Macro-program examples | 87 |
| 7.1 Multi-speed control operation | 87 |
| 7.2 The internal control with eight periods of speed | 87 |
| 7.3 PID control operation | 87 |
| CHAPTER 8 - Application macro | 88 |
| 8.1 Comprehensive macro 1 | 89 |
| 8.2 Comprehensive macro 2..... | 91 |
| 8.3 Comprehensive macro 3..... | 93 |
| 8.4 Comprehensive macro 4..... | 95 |
| 8.5 1-Line command macro | 97 |
| 8.6 2-Line command macro 1..... | 97 |
| 8.7 2-Line command macro 2..... | 98 |
| 8.8 3-Line command macro 1..... | 98 |
| 8.9 3-Line command macro 2..... | 99 |
| 8.10 Main and auxiliary settings | 100 |
| 8.11 Multi-stage speed macro | 101 |
| 8.12 PID macro 1..... | 102 |
| 8.13 PID macro 2..... | 103 |
| 8.14 Speed start macro | 104 |
| 8.15 DC injection macro..... | 104 |
| 8.16 Free parking macro | 104 |
| 8.17 DC brake macro | 104 |
| 8.18 Emergency acceleration macro | 105 |
| 8.19 Emergency deceleration macro..... | 105 |
| 8.20 Console switch macro | 106 |
| 8.21 Frequency reach macro | 107 |
| 8.22 FDT macro | 108 |
| 8.23 Acceleration and deceleration switching macro..... | 109 |
| 8.24 Brake signal macro | 111 |
| 8.25 Release signal macro | 112 |
| 8.26 Break detection macro | 113 |
| 8.27 Signal loss macro | 114 |
| 8.28 Internal control eight-stage speed macro..... | 115 |
| CHAPTER 9 - RS485 communication | 117 |
| 9.1 Introduction..... | 117 |
| 9.2 Specifications..... | 117 |
| 9.3 Communication protocol | 117 |
| 9.3.1 Format description..... | 117 |
| 9.3.2 Address coding..... | 117 |
| 9.3.3 Read holding register..... | 119 |
| 9.3.4 Preset a single register..... | 120 |
| 9.3.5 Preset multiple registers | 120 |
| 9.3.6 Communication error codes..... | 121 |
| CHAPTER 10 - Fault exclusion and repair | 122 |
| 10.1 Protection function | 122 |

| | | |
|------------|---|-----|
| 10.2 | Fault code table..... | 122 |
| 10.3 | Maintenance and inspection prevention..... | 122 |
| 10.4 | Checkpoint..... | 123 |
| 10.5 | Parts replacement..... | 123 |
| CHAPTER 11 | - Technical Notes..... | 123 |
| CHAPTER 12 | - Selection of braking resistor..... | 124 |
| 12.1 | Brake resistor configuration table..... | 124 |
| 12.2 | Installation dimension drawing of braking resistor..... | 125 |
| CHAPTER 13 | - Dimensions..... | 126 |
| CHAPTER 14 | - Quick parameter configuration table..... | 127 |
| CHAPTER 15 | - Standard card (H0101) instructions for use..... | 129 |
| 15.1 | Overview..... | 129 |
| 15.2 | Mechanical installation..... | 129 |
| 15.3 | Wiring diagram..... | 130 |
| 15.4 | Control terminal..... | 130 |
| CHAPTER 16 | - H0110 card instructions for use..... | 132 |
| 16.1 | Overview..... | 132 |
| 16.2 | Mechanical installation..... | 132 |
| 16.3 | Wiring diagram..... | 133 |
| 16.4 | Control terminal..... | 133 |
| 16.5 | H0110 card application engraving machine instructions..... | 135 |
| 16.6 | H0110 card application constant pressure water supply instructions..... | 137 |
| CHAPTER 17 | - Standard card (H0100) instructions..... | 139 |
| 17.1 | Overview..... | 139 |
| 17.2 | Mechanical installation..... | 140 |
| 17.3 | Wiring diagram..... | 140 |
| 17.4 | Control terminal..... | 140 |
| CHAPTER 18 | - H0200 card instructions for use..... | 142 |
| 18.1 | Overview..... | 142 |
| 18.2 | Mechanical installation..... | 142 |
| 18.3 | Wiring diagram..... | 143 |
| 18.4 | Control terminal..... | 144 |
| 18.5 | Operator description..... | 145 |
| 18.6 | Inverter safety switch STO function..... | 146 |
| CHAPTER 19 | - H0201 card instructions for use..... | 147 |
| 19.1 | Overview..... | 147 |
| 19.2 | Mechanical installation..... | 147 |
| 19.3 | Wiring diagram..... | 148 |
| 19.4 | Control terminal..... | 149 |
| 19.5 | Operator description..... | 149 |
| CHAPTER 20 | - OP-H101 external keyboard simple instructions..... | 151 |
| CHAPTER 21 | - OP-H102 external keyboard simple instructions..... | 152 |

SAFETY PRECAUTIONS

- Always observe safety precautions to prevent accidents and potential hazards.
- In this manual, the safety information is classified as below:
 - WARNING** Fault operation may result in serious personal injury or death.
 - CAUTION** Fault operation may result personal injury or property damage from minor to moderate class.
 - In this manual, the following two signs are used as safety precautions:
 - 1) Under certain conditions, identify dangers that cause personal injury. Since dangerous voltages may exist, special attention should be paid.
 - 2) Under certain conditions, identify potential hazards. Read the information carefully and follow the instructions.
 - For convenience, please save it nearby.
 - Read this manual carefully to optimize the performance of H1 series inverter and ensure safe use.

WARNING

- Do not open the casing in case of electric shock when the power supply has been supplied or the inverter is in the running state.
- Do not operate the inverter when the front-cover of the inverter is opening. In case of shocked by high voltage or exposed charging capacitors.
- Do not open the inverter's casing except for periodic inspection or wiring, even if the inverter is not connected to input voltage. In case of get an electric shock from the charging circuit.
- Wiring and periodic maintain should be performed after removing the input power and using the instrument to discharge the DC voltage (below DC 30V) for at least 10 minutes. In case of electric shock.
- Start the switch with dry hands in case of get an electric shock.
- Do not use cables with damaged insulation in case of an electric shock.
- Do not make the cable to scratches, pinch, overvoltage or overload in case of an electric shock.

NOTES

- The inverter should be installed on a non-flammable surface, and do not place flammable materials nearby. Otherwise, a fire may occur.
- If the inverter is damaged, immediately disconnect the input power in case of causing secondary damage to the equipment or fire.
- After the input power is disconnected, the residual heat of the inverter will remain for several minutes. Do not touch it. Otherwise, you may be physically injured (for example: skin burns or injuries).
- Do not power on the inverter that is damaged or missing parts, even if the installation has been completed. Otherwise, electric shock may occur.
- Burlap, paper dust, wood dust, dust, metal fragments or other miscellaneous objects are not allowed to enter the inverter. Otherwise, fire or accident may occur.

OPERATIONAL PRECAUTIONS

(1) Maintenance and installation

- Handle according to the weight of the product.
- The number of stacked inverter packaging boxes should not exceed the specified number.
- Installation according to the instructions in this manual.
- Do not open the casing during delivery.
- Do not place heavy objects on the inverter.
- Check if the inverter's packing direction is correct.
- Do not drop or squeeze the inverter.
- For 200V inverters, use category 3 grounding method (grounding resistance <math>< 100\Omega</math>), For 400V inverters (grounding resistance <math>< 10\Omega</math>)
- H1 series contains ESD (electrostatic discharge) sensitive parts. When inspecting or installing, be careful to take protective measures (electrostatic discharge) before touching the printed circuit board.
- Use the inverter under the following environmental conditions.

Table 0-1: Environmental conditions

| | | |
|-------------|-------------------------|---|
| Environment | Environment Temperature | -10°C~+40°C(Ambient temperature is 40°C~50°C, please derating use;Downshift usage if the temperature is below -10°C) |
| | Humidity | 5%~95%RH, No condensation |
| | Storage temperature | -40°C~+70°C |
| | Installation site | Indoor, no direct sunlight, no dust, corrosive gas, flammable gas, oil mist, water vapor, dripping water or salt etc. |
| | Vibration | For derating above 1000 meters, derate 10% for every 1000 meters |
| | Altitude | Less than 5.9 m / s^2 (0.6g) |

(2) Wiring

- Do not install power capacitors, surge suppressors, or RFI filters on the output side of the inverter.
- The connection method of the output cables (U, V, W) connected to the motor will affect the rotation direction of the motor.
- Incorrect terminal wiring may cause damage to the device.
- If the positive and negative poles of the terminals are reversed, the inverter may be damaged.
- Only personnel who are familiar with the H1 inverter can wire and inspect the inverter.
- Install the inverter before wiring, otherwise, you may get an electric shock or personal injury.

(3) Trial operation

- Check all parameters before operation and modify the parameter values according to the load type.
- Always use within the voltage range in this manual, otherwise the inverter may be damaged.

(4) Operation prevention

- When the automatic restart function is selected, since the motor will restart suddenly after the fault stops, it should be away from the device.
- The "STOP" key on the operation keyboard is only effective when the corresponding function settings have been set, and special circumstances should be prepared for emergency stop switch.

- If the fault reset is set using external terminals, a sudden start will occur. Please check in advance whether the external terminal signal is in the off position, in case of an accident may occur.
- Do not modify or change anything inside the inverter.
- The electronic thermal protection function of the inverter may not protect the motor.
- Do not use electromagnetic AC contactor as the switch for frequent start and stop of the inverter on the input side of the inverter.
- Use a noise filter to reduce the influence of electromagnetic interference generated by the inverter, in case of nearby electronic equipment may be interfered.
- If the input voltage is unbalanced, an AC reactor needs to be installed. The potential higher harmonics from the inverter may cause the power capacitor and generator to become hot or damaged.
- After the parameters are initialized, the parameter values are restored to the factory settings, and the parameters need to be set again before running.
- The inverter can be easily set to high-speed operation. Check the capacity of the motor or mechanical equipment before operation.
- When the DC braking function is used, there will be no stopping torque. When it is necessary to stop the torque, install a separate device.
- When driving 380V inverters and motors, use insulated rectifiers and take measures to suppress surge voltage. The surge voltage caused by the wiring constant problem at the motor terminals may damage the insulation and damage the motor.

(5) Accident prevention

- Prepare a safety device such as an emergency braking device, to prevent the use of machinery and equipment in a more dangerous environment if the inverter has problems.

(6) Maintenance, inspection and parts replacement

- Do not test the control circuit of the inverter (insulation resistance measurement) with a high resistance meter.
- Regular inspection.

(7) Disposal

- Disposal as industrial waste after broken.

(8) General notes

- Most charts or drawings in this manual indicate that if the inverter is not equipped with a circuit breaker, enclosure or partial open circuit, the inverter must never be operated. When operating the inverter, always install the enclosure and circuit breaker, and observe the regulations in the installation manual.

H1 series nameplate

H1 00 S2 0007 B T 0

- 0: No built-in reactor
- 1: Built-in DC reactor
- 2: Built-in AC reactor
- 3: Built-in DC and AC reactors
- T: Built-in STO circuit X: No STO circuit
- B: Built-in brake unit X: No brake unit
- Power: kW
- First three digits: before the decimal point, one digit after the decimal point
- Example: 0007: 0.75kW
- S/T: Single-phase/Three-phase
- 2/4: 220/380V
- Custom machine model
- Product model (H1 series)

H1 Series Specification

| Frame NO. | Model | Input voltage | Input current(A) | Rated power (kW) | Output current(A) | Motor (kW) | | | |
|-----------|---------------|-------------------|------------------|------------------|-------------------|------------|------|-----|------|
| F1 | H100S20007BX0 | Single-phase 220V | 8.2 | 0.75 | 5.0 | 0.75 | | | |
| | H100S20015BX0 | Single-phase 220V | 14.0 | 1.5 | 7.0 | 1.5 | | | |
| F2 | H100T20022BX0 | Single-phase 220V | 23.0 | 2.2 | 12.5 | 2.2 | | | |
| | | Three-phase 220V | 13.5 | | | | | | |
| F3 | H100T20037BX0 | Single-phase 220V | 38.6 | 3.7 | 15.2 | 3.7 | | | |
| | | Three-phase 220V | 16.5 | | | | | | |
| F4 | H100T20055BX0 | Three-phase 220V | 24 | 5.5 | 23 | 5.5 | | | |
| | | Three-phase 220V | 37 | | | | 7.5 | 31 | 7.5 |
| F4 | H100T20110BX0 | Three-phase 220V | 52 | 11 | 45 | 11 | | | |
| | | Three-phase 220V | 52 | | | | 11 | 45 | 11 |
| F1 | H100T40007BX0 | Three-phase 380V | 4.0 | 0.75 | 3.0 | 0.75 | | | |
| | | Three-phase 380V | 5.8 | | | | 1.5 | 4.5 | 1.5 |
| | | Three-phase 380V | 6.5 | | | | 2.2 | 5.6 | 2.2 |
| F2 | H100T40040BX0 | Three-phase 380V | 12.6 | 4.0 | 10.5 | 4.0 | | | |
| | | Three-phase 380V | 16 | | | | 5.5 | 14 | 5.5 |
| F3 | H100T40075BX0 | Three-phase 380V | 21 | 7.5 | 19 | 7.5 | | | |
| | | Three-phase 380V | 28 | | | | 11 | 26 | 11 |
| F4 | H100T40150BX0 | Three-phase 380V | 36 | 15 | 33 | 15 | | | |
| | | Three-phase 380V | 42 | | | | 18.5 | 40 | 18.5 |
| F5 | H100T40220BX0 | Three-phase 380V | 48 | 22 | 46 | 22 | | | |
| | | Three-phase 380V | 62 | | | | 30 | 58 | 30 |
| F6 | H100T40300BX0 | Three-phase 380V | 62 | 30 | 58 | 30 | | | |
| | | Three-phase 380V | 76 | | | | 37 | 75 | 37 |
| F7 | H100T40450XX0 | Three-phase 380V | 92 | 45 | 90 | 45 | | | |
| | | Three-phase 380V | 113 | | | | 55 | 110 | 55 |
| F8 | H100T40750XX0 | Three-phase 380V | 157 | 75 | 150 | 75 | | | |
| | | Three-phase 380V | 180 | | | | 90 | 170 | 90 |
| F9 | H100T41100XX0 | Three-phase 380V | 214 | 110 | 210 | 110 | | | |
| | | Three-phase 380V | 256 | | | | 132 | 250 | 132 |
| | | Three-phase 380V | 307 | | | | 160 | 300 | 160 |

CHAPTER 1 - Installation

1.1 Installation prevention



- The inverter uses plastic parts, so be careful not to damage it. Do not grab the front keyboard to move the inverter in case of fall.
- The inverter is installed without vibration (5.9 m / s² or less).
- Install the inverter within the allowable temperature range (-10 ~ 50C).
- The temperature of the inverter during operation is very high, and the inverter needs to be installed on a non-flammable surface.
- Install the inverter on smooth, vertical and horizontal surfaces. The direction of the inverter must be vertical for heat dissipation. At the same time, leave enough space around the inverter.

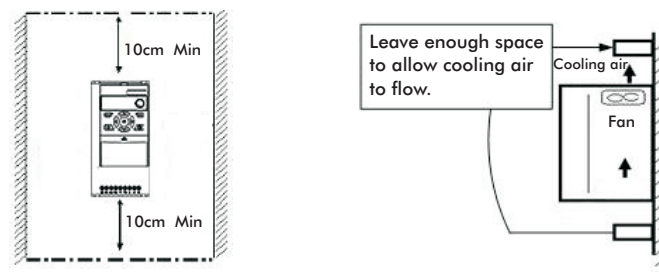

Chart 1-1 Installation instructions

Avoid moisture and direct sunlight.

Do not install the inverter in places with oil gas, flammable gas and dust. Install the inverter in a clean place or in a closed plate that isolates foreign materials.

When two or more inverters are installed on one space, the inverter or cooling fan must be installed in a suitable location to ensure that the surrounding temperature is within the allowable range.

When installing the inverter, use screws for fixing to ensure that the inverter is firmly installed.

CHAPTER 2 - Basic Configuration

2.1 Peripheral device connection

The following equipment is required to operate the inverter. Select appropriate peripheral device and connect it correctly to ensure normal operation. Fault application or installation of the inverter may cause system failure or reduce product life and damage components. Before proceeding, you must read and fully understand the manual.

| | | |
|--|--|--|
| | AC power | Please use the power supply within the allowable specifications of the inverter. |
| | MCCB or earth leakage circuit breaker (ELB). | Choose an appropriate circuitbreaker. When the power is turned on, a large inrush current will flow into the inverter. |
| | Electromagnetic contactor | Install it if necessary. After installation, do not use it for the purpose of starting or stopping. Otherwise, it may cause a reduction in product life. |
| | AC/DC reactor | Choosing an appropriate reactor can suppress higher harmonics and improve power factor. Use it as close to the inverter as possible. |
| | Installation and connection | Install the inverter in a suitable place and maintain a good ground. Incorrect connection may cause damage to the device. |
| | Connect the motor | Please select inverter motor for long-term low-speed operation. |

Chart 2-1 Diagram connection of outside equipments and inverter

2.2 List of main circuit applicable devices and their electrical specifications

| Voltage class (V) | Inverter rated power (kW) | Motor (kW) | Inverter input | | Recommended wiring size(mm ²) | | | |
|-------------------|---------------------------|----------------|------------------|-----------------|---|------------|-----------------|---------------------------------------|
| | | | Air-switch model | Contactor model | Power line (input/output line) | DC reactor | Braking circuit | Control signal wire (external wiring) |
| 220 | 0.75 | 0.75 | DZ20-100(16A) | CJ20-16 | 2.5 | 4 | 2.5 | 0.5~0.75 |
| | 1.5 | 1.5 | | | | | | |
| | 2.2 | 2.2 | | | | | | |
| | 3.7 | 3.7 | | | | | | |
| | 5.5 | 5.5 | DZ20-100(32A) | CJ20-40 | | | | |
| | 7.5 | 7.5 | | | | | | |
| 11 | 11 | DZ20-100(63A) | CJ20-63 | 8 | 8 | 6 | | |
| 380 | 0.75 | 0.75 | DZ20-100(16A) | CJ20-16 | 1.5 | 4 | 1.5 | |
| | 1.5 | 1.5 | | | | | | |
| | 2.2 | 2.2 | | | | | | |
| | 4.0 | 4.0 | | | 2.5 | 4 | 2.5 | |
| | 5.5 | 5.5 | | | | | | |
| | 7.5 | 7.5 | DZ20-100(32A) | CJ20-25 | 4 | 6 | 4 | |
| | 11 | 11 | DZ20-100(50A) | CJ20-40 | 6 | 8 | 6 | |
| | 15 | 15 | | | 8 | | | |
| | 18.5 | 18.5 | | | 10 | | | |
| | 22 | 22 | DZ20-100(63A) | CJ20-63 | 10 | 16 | 6 | |
| | 30 | 30 | DZ20-100(80A) | CJ20-63 | 10 | 16 | 6 | |
| | 37 | 37 | DZ20-100(100A) | CJ20-100 | 16 | 16 | 6 | |
| | 45 | 45 | | | 25 | 25 | 8 | |
| | 55 | 55 | | | 35 | 25*2(50) | 8 | |
| | 75 | 75 | DZ20-200(200A) | CJ20-160 | 50 | 35*2(70) | 10 | |
| 90 | 90 | DZ20-400(250A) | CJ20-250 | 70 | 50*2(95) | 16 | | |
| 110 | 110 | | | 25 | | | | |
| 132 | 132 | | | 50*2(95) | | 70*2(150) | 25 | |
| 160 | 160 | 70*2(150) | | | | | | |

CHAPTER 3 - Wiring

3.1 Main circuit and function card

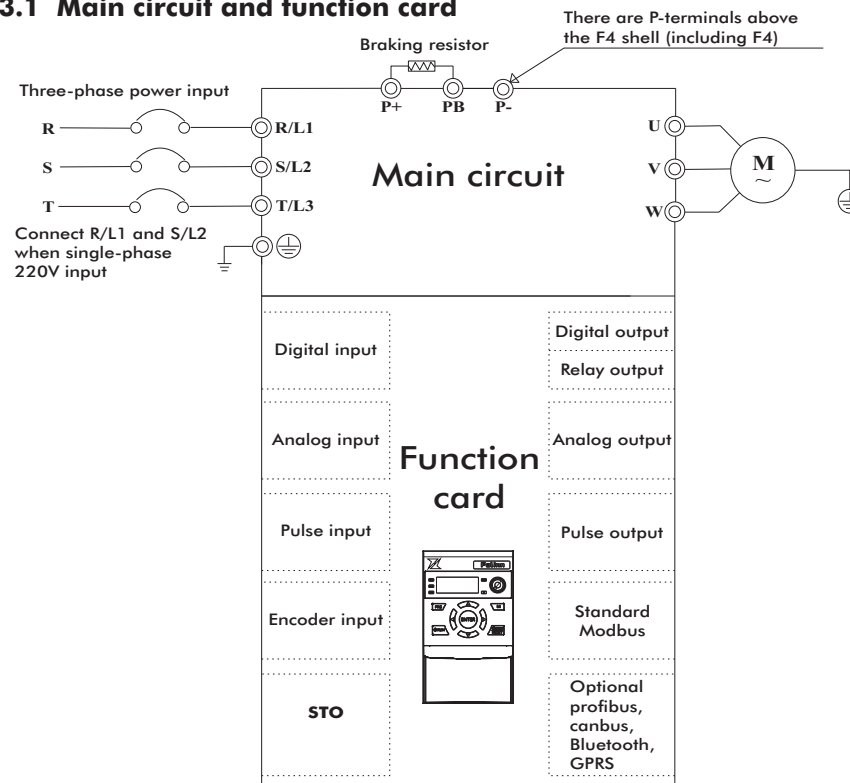

Chart 3-1 Main circuit and function card

Note: Different function cards connect to different terminals. In addition to standard function cards, any type of card can be customized. When using different function cards, the parameters need to be reset.

Warning: It is strictly forbidden to plug and unplug the function card with power on!

3.2 Power terminal wiring instructions

Warning

- For 220V class inverter, use class 3 grounding method (grounding resistance: less than 100Ω).
- For 380V class inverter, use class 3 grounding method (grounding resistance: less than 10Ω).
- Use special grounding terminal for grounding. Do not use screws for grounding in the box.
- Note: Grounding steps
 - Determine the location of the ground terminal.
 - Connect the ground-wire to the ground terminal and make sure that the screws are tight.

3.3 Main circuit terminal description

| Terminal symbol | Terminal name | Function description |
|-----------------|-----------------------------------|--|
| | Ground terminal | Inverter safety ground |
| R/L1、S/L2、T/L3 | Main circuit power input terminal | Connect three-phase power, single-phase power to R / L1, S / L2 |
| P+, PB | Brake terminal | Connect external braking resistor |
| P+, P- | DC bus terminal | when two or more inverters share a DC bus(There are P-terminals above the F4 shell (including F4)) |
| U、V、W | Inverter output terminal | Connect a three-phase motor |

- Please implement the wiring in accordance with the regulations of electrician regulations to ensure safety. When selection of the wire diameter specification
- It is best to use isolated wires or conduits for power wiring, and ground the isolation layer or conduits at both ends.
- Be sure to install the air disconnect switch NFB between the power supply and the input terminals (R / L1, S / L2, T / L2)
- Do not connect the AC power supply to the output terminal (U V W) of the inverter.
- The output wiring must not touch the metal shell of the inverter, in case of a short circuit to ground.
- Do not use phase shift capacitors, LC / RC noise filters and other components at the output of the inverter.
- The main circuit wiring of the inverter must be far away from other control equipment.
- When the wiring between the inverter and the motor exceeds 15 meters (220V level),(380V level 30 meters), a high dV / dT will be generated inside the motor coil, which will produce interlayer insulation of the motor then damaged, please use a special motor for the inverter or install a reactor on the inverter side.

Ground wire:

- Please correctly ground the grounding wire terminal PE:
220V level: The 3 class grounding (grounding resistance below 100Ω).
380V level: Special 3 class grounding (grounding resistance below 10Ω).
- For the use of the ground wire, please follow the basic length and size of the electrical equipment technology.
- Use special grounding terminal for grounding. Do not use screws for grounding in the box.
- Absolutely avoid public grounding with large power equipment such as welding machines, power machinery, etc. The ground wire should be as far away as possible from the ground wire of large power equipment.
- The ground wiring must be as short as possible.

Note: Grounding steps

- (1) Remove the front keyboard
- (2) Connect the ground wire to the ground terminal and ensure that the screws are tight.

3.4 Function card configuration table

| H0001 | Function configuration | Board name | H0100 | H0101 | H0102 | H0103 | H0104 | H0110 | H0120 | H0130 | H0131 | H0200 | H0201 | H0300 | H0310 | H0320 | H0350 |
|-------|---|-------------|-------|-------|-------|-------|-------|-------|-------|-------|-------|-------|-------|-------|-------|-------|-------|
| | HOUSING: SK10:1; SK20:2; SK30:3; --- Reserve Built in function card | Shell model | SK10 | | | | | | | | | SK20 | | SK30 | | | |
| | | Appearance | | | | | | | | | | | | | | | |

| Function card | H0100 | H0101 | H0102 | H0103 | H0104 | H0110 | H0120 | H0130 | H0131 | Conti-nupus update | H0200 | H0201 | Conti-nupus update | H0300 | H0310 | H0320 | H0350 | Conti-nupus update |
|--------------------------|--------------|--------------|--------------|--------------|--------------|--------------|--------------|--------------|--------------|--------------------|--------------|--------------|--------------------|--------------|--------------|--------------|-------|--------------------|
| Physical characteristics | 2 | 4 | 1 | 4 | 2 | 5 | 10 | 5 | 1 | | 10 | 10 | | | 4 | 5 | 3 | |
| Digital input | | | | | | | | | | | | | | | | | | |
| Digital output | | | | | | | | | | | | | | | | | | |
| Relay output | 1 | 1 | | 3 | 1 | 2 | 2 | 2 | 1 | | 3 | 3 | | | 1 | 1 | 1 | |
| Analog input | 1 | 1 | | 1 | 1 | 1 | 1 | 1 | | | 2 | 2 | | | 2 | 1 | | |
| Analog output | | | | | | 2 | 1 | 2 | | | 2 | 2 | | | 2 | 2 | | |
| Pulse input | | | | | | | | | | | | | | | | | | |
| Pulse output | | | | | | | | | | | | | | | | | | |
| Encoder input | | | | | | | | | | | | | | | | | | |
| Modbus | 1 | 1 | 1 | 1 | | 1 | optional | 1 | 1 | | 1 | 1 | | | 1 | 1 | 1 | |
| STO | | | | | | | | | | | | | | | | | | |
| Display | Digital tube | Digital tube | Digital tube | Digital tube | Digital tube | Digital tube | Digital tube | Digital tube | Digital tube | | Digital tube | Digital tube | | Digital tube | Digital tube | Digital tube | | |
| Potentiometer | Analog | Analog | | Analog | Analog | Analog | Analog | Analog | | | | | | Analog | Analog | | | |
| Toggle switch | | | | | | | | | | | | | | 1 | 2 | 2 | | |
| 10V power supply | | 1 | | 1 | 1 | 1 | 1 | 1 | | | 1 | 1 | | | 1 | | | |
| 12V power supply | | | | 1 | | | 1 | 1 | 1 | | 1 | 1 | | | 1 | | | |

- Note:
1. the built-in function card with STO function must be equipped with AC drive of STO circuit, for example: H0200 built-in function card is equipped with AC drive with model H100T40040BT0 (the second T represents built-in STO circuit).
 2. If need other types and numbers of terminals, contact the company for bulk customization

CHAPTER 4 - Keyboard

4.1 Keyboard Features

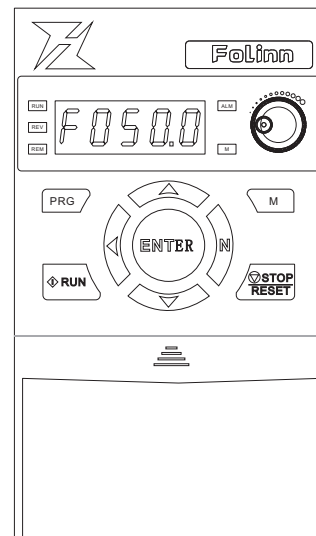

| No. | Construction | Function explain |
|-----|--------------|--|
| 1 | | Display |
| 2 | | Programming/ Exit key |
| 3 | | In the state display interface, it is the state switch key; in other interfaces, it is the left shift key |
| 4 | | Reserved key |
| 5 | | Run key |
| 6 | | Potentiometer: see parameter P01.63 |
| 7 | | In programming mode, value change key; In non-programming mode, increasing and decreasing (UP / DOWN) selection key. See parameters P01.63, P02.03, P02.04 |
| 8 | | |
| 9 | | Enter |
| 10 | | Stop/reset |
| 11 | | Customized key |

| Indicator light | State | Function Detail |
|-----------------|---------------|---|
| RUN | Light / Flash | Running/Decelerate |
| REV | Light | Reversing |
| REM | Light | Remote operation |
| ALM | Light | Fault indication |
| M | Light | Customer customized instructions, fault alarm instructions, see parameters P01.66 and P01.67. |

4.2 Keyboard operation

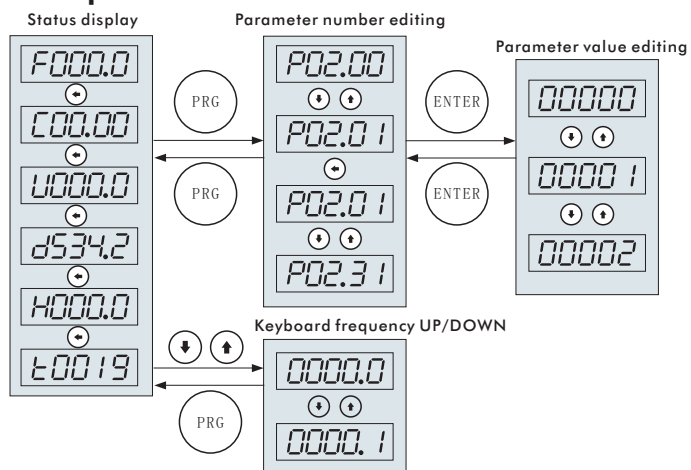

| Item | Description | Item | Description |
|----------|------------------|----------|--------------------------------------|
| <i>F</i> | Output frequency | <i>H</i> | Display value 1 (selected by P01.68) |
| <i>C</i> | Output current | <i>t</i> | Display value 2 (selected by P01.69) |
| <i>U</i> | Output voltage | <i>A</i> | Alarm |
| <i>d</i> | DC bus voltage | <i>E</i> | Fault |

4.3 Character display

| | | | | | | | |
|---|---|----------|---|----------|---|----------|---|
| 0 | 0 | <i>A</i> | A | <i>K</i> | K | <i>U</i> | U |
| 1 | 1 | <i>b</i> | B | <i>L</i> | L | <i>v</i> | V |
| 2 | 2 | <i>C</i> | C | <i>M</i> | M | <i>W</i> | W |
| 3 | 3 | <i>d</i> | D | <i>N</i> | N | <i>X</i> | X |
| 4 | 4 | <i>E</i> | E | <i>O</i> | O | <i>Y</i> | Y |
| 5 | 5 | <i>F</i> | F | <i>P</i> | P | <i>Z</i> | Z |
| 6 | 6 | <i>G</i> | G | <i>Q</i> | Q | | |
| 7 | 7 | <i>H</i> | H | <i>R</i> | R | | |
| 8 | 8 | <i>I</i> | I | <i>S</i> | S | | |
| 9 | 9 | <i>J</i> | J | <i>T</i> | T | | |

CHAPTER 5 - Quick get start

Note:

Some parameters have been set at the factory (factory value), and do not be set for the first use.

5.1 Set the motor rated parameters

After power on, use the operation keyboard to set the parameters as the following table. According to the motor nameplate for motor parameters.

| Parameter number | Function | Parameter number | Function |
|------------------|-----------------------|------------------|---------------------|
| P06.11 | Motor rated Power | P06.14 | Motor rated current |
| P06.12 | Motor rated Voltage | P06.15 | Motor rated speed |
| P06.13 | Motor rated frequency | | |

5.2 Use the keyboard to control the start-stop and use the keyboard potentiometer to set the operating frequency

5.2.1 Power on. Use the operation keyboard to set the motor parameters (P06.11 ~ P06.15), keyboard potentiometer to control speed and acceleration / deceleration time (P02.50, P02.70).

| Parameter number | Function | Set value | Detail |
|------------------|--------------------------|-------------------|--|
| P01.63 | Keyboard settings source | 1 (Factory Value) | The operating frequency is set by the keyboard potentiometer |
| P02.10 | Set value source 1 | 0 (Factory Value) | The operating frequency is set by the keyboard |
| P03.00 | Start command source | 1 (Factory Value) | Operation keyboard to run command channel |
| P02.50 | Acceleration time 0 | - | The acceleration time is adjusted according to actual needs |
| P02.70 | Deceleration time 0 | - | The deceleration time is adjusted according to actual needs |

5.2.2 Press the RUN key on the operation keyboard to start the inverter, rotate the potentiometer on the keyboard to adjust the set frequency, and press the STOP key to stop the inverter.

5.3 Use the terminals to control start-stop and use the keyboard to set operating frequency

5.3.1 Terminal S1 is for forward signal input, and S2 is for reverse signal input. The wiring is as shown in the figure below.

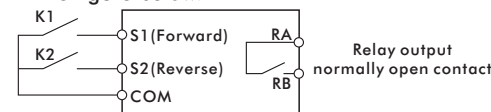

5.3.2 Power on, then set the function parameters according to the wiring diagram, see the table as below.

| Parameter number | Function | Set value | Detail |
|------------------|------------------------------------|-------------------|---|
| P01.63 | Keyboard settings source | 0 | Keyboard setting source is set by P02.92 number |
| P02.03 | Source of incremental command (UP) | 1 | Increment command (UP) source keyboard |
| P02.04 | Source of decrement command (DOWN) | 1 | Decrease command (DOWN) source keyboard |
| P02.10 | Set value source 1 | 0 (Factory Value) | The operating frequency is set by the keyboard |
| P02.92 | Keyboard set value | - | Operating frequency, relative to P02.18 percentage |
| P02.50 | Acceleration time 0 | - | Acceleration time is adjusted according to actual needs |
| P02.70 | Deceleration time 0 | - | Deceleration time is adjusted according to actual needs |
| P03.00 | Start command source | 3 | Forward running function (terminal forward rotation signal input) |
| P03.01 | Reverse start command source | 4 | Reverse running function (terminal reverse signal input) |

5.3.3 When K1 in the wiring diagram is closed, the motor runs forward; when K1 is disconnected, the motor stops running. When K2 is closed, the motor runs in reverse; when K2 is disconnected, the motor stops running. When K1 and K2 are closed or opened at the same time, the motor stops running. You can increase / decrease the set frequency by set the value of P02.92 or pressing ▲ and ▼ on the operation keyboard.

5.4 Use the terminals to control start-stop and use analog to set operating frequency

5.4.1 Terminal S1 is for forward signal input, and S2 is for reverse signal input. The wiring is shown in the figure below.

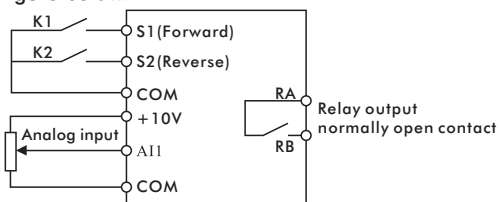

5.4.2 Power on, then set the function parameter table according to the wiring diagram, see the table below.

| Parameter number | Function | Set value | Detail |
|------------------|------------------------------|-----------|--|
| P02.10 | Set value source 1 | 2 | The operating frequency is set by analog quantity A11 |
| P02.50 | Acceleration time 0 | - | The acceleration time is adjusted according to the actual demand |
| P02.70 | Deceleration time 0 | - | The deceleration time is adjusted according to the actual demand |
| P03.00 | Start command source | 3 | Forward rotation function (terminal forward rotation signal input) |
| P03.01 | Reverse start command source | 4 | Reverse function (terminal reverse signal input) |

5.4.3 Set the operating frequency by adjusting the A11 analog input.

5.4.4 When K1 in the wiring diagram is closed, the motor runs forward; when K1 is disconnected, the motor stops running. When K2 is closed, the motor runs in reverse; when K2 is disconnected, the motor stops running. When K1 and K2 are closed or opened at the same time, the motor stops running.

5.5 Process control PID: Multi-speed 0 is set value, A11 is feedback value

5.5.1 Terminal S1 is the forward signal input, A11 is the feedback signal input. The wiring is shown below.

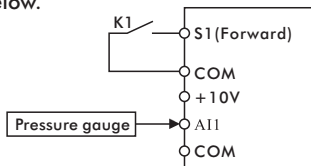

5.5.2 Power on, then set the function parameter table according to the wiring diagram, see the table below.

| Parameter number | Function | Set value | Detail |
|------------------|--------------------------------------|-----------|---|
| P02.10 | Set value source 1 | 1 | PID set value selected multi-step speed 0: 100% of full scale |
| P02.11 | Set value source 2 | 2 | PID feedback selected analog A11: 10V corresponds to full scale |
| P02.13 | Set channel relationship | 8 | Activate PID control |
| P02.30 | Multi-speed 0 | - | PID set pressure |
| P03.00 | Start command source | 3 | Select S1 as the source of the operation command |
| P04.00 | PID proportional gain | - | Set as required, the greater the value, the faster the adjustment |
| P04.01 | PID integration time | - | Set as required, the smaller the value, the faster the adjustment |
| P01.68 | Keyboard H monitoring item selection | 1090 | Item H displays P10.90, which is the PID setting value |
| P01.69 | Keyboard L monitoring item selection | 1091 | The L item shows P10.91, which is the PID feedback value |

5.5.3 Adjust the P02.30 to get the desired pressure.

5.5.4 When K1 in the wiring diagram is closed, the system starts to run.

5.6 Use the terminals to control start-stop and use communication to set running frequency

5.6.1 Terminal S1 is for forward signal input and S2 is for reverse signal input. The wiring is as shown in the figure below.

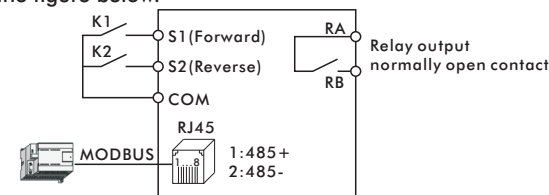

5.6.2 Power on, then set the function parameters according to the wiring diagram, see the table below.

| Parameter number | Function | Set value | Detail |
|------------------|------------------------------|---------------------|--|
| P01.40 | Communication Protocol | 1 (Factory Value) | MODBUS RTU |
| P01.41 | Address | 1 (Factory Value) | Slave address 1 |
| P01.42 | Baud rate | 3 (Factory Value) | 19200bps |
| P01.43 | Parity check | 0 (Factory Value) | No check |
| P01.45 | Stop bit | 1.0 (Factory Value) | 1 bit |
| P02.10 | Set value source 1 | 5 | MODBUS communication settings |
| P02.50 | Acceleration time 0 | - | The acceleration time is adjusted according to actual needs |
| P02.70 | Deceleration time 0 | - | Deceleration time is adjusted according to actual needs |
| P03.00 | Start command source | 3 | Forward rotation function (terminal forward rotation signal input) |
| P03.01 | Reverse start command source | 4 | Reverse function (terminal reverse signal input) |

5.6.3 When K1 in the wiring diagram is closed, the motor runs forward; when K1 is disconnected, the motor stops running. When K2 is closed, the motor runs in reverse; when K2 is disconnected, the motor stops running. When K1 and K2 are closed or opened at the same time, the motor stops running.

5.6.4 Modify the running frequency by writing register 0x0121 through MODBUS communication (function code 0x06). For example: modify the running frequency 25Hz of slave address 1, see the table below.

| | Address | Function code | Register address | Register content | Sum of Check |
|---------------|---------|---------------|------------------|------------------|---------------------|
| Request frame | 0x01 | 0x06 | 0x01 | 0x21 | 0xC3 0x50 0x88 0xF0 |
| Reply frame | 0x01 | 0x06 | 0x01 | 0x21 | 0xC3 0x50 0x88 0xF0 |

5.7 Use communication to control start-stop and communication to set operating frequency

5.7.1 Connect the communication cable as shown below.

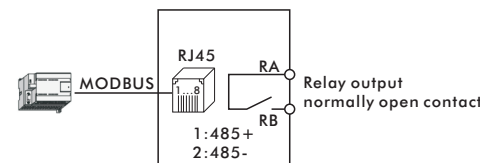

5.7.2 Power on, then set the function parameters according to the wiring diagram, see the table below.

| Parameter number | Function | Set value | Detail |
|------------------|------------------------|---------------------|---|
| P01.40 | Communication Protocol | 1 (Factory Value) | MODBUS RTU |
| P01.41 | Address | 1 (Factory Value) | Slave address 1 |
| P01.42 | Baud rate | 3 (Factory Value) | 19200bps |
| P01.43 | Parity check | 0 (Factory Value) | No check |
| P01.45 | Stop bit | 1.0 (Factory Value) | 1 bit |
| P02.10 | Set value source 1 | 5 | MODBUS communication settings |
| P02.50 | Acceleration time 0 | - | The acceleration time is adjusted according to actual needs |
| P02.70 | Deceleration time 0 | - | The deceleration time is adjusted according to actual needs |
| P03.00 | Start command source | 2 | MODBUS communication start-stop |

5.7.3 Start or stop the inverter whose slave address is 1 by writing register 0x0122 through MODBUS communication (function code 0x06).

Such as: start command, see the table below.

| | Address | Function code | Register address | Register content | Sum of Check |
|---------------|---------|---------------|------------------|------------------|--------------|
| Request frame | 0x01 | 0x06 | 0x01 0x22 | 0x00 0x01 | 0xE9 0xFC |
| Reply frame | 0x01 | 0x06 | 0x01 0x22 | 0x00 0x01 | 0xE9 0xFC |

Such as: stop command, see the table below.

| | Address | Function code | Register address | Register content | Sum of Check |
|---------------|---------|---------------|------------------|------------------|--------------|
| Request frame | 0x01 | 0x06 | 0x01 0x22 | 0x00 0x10 | 0x29 0xF0 |
| Reply frame | 0x01 | 0x06 | 0x01 0x22 | 0x00 0x10 | 0x29 0xF0 |

5.7.4 Modify the operating frequency by writing register 0x0121 through MODBUS communication (function code 0x06). For example: modify the running frequency 20Hz of slave address 1, see the table below.

| | Address | Function code | Register address | Register content | Sum of Check |
|---------------|---------|---------------|------------------|------------------|--------------|
| Request frame | 0x01 | 0x06 | 0x01 0x21 | 0x9C 0x40 | 0xB0 0xCC |
| Reply frame | 0x01 | 0x06 | 0x01 0x21 | 0x9C 0x40 | 0xB0 0xCC |

CHAPTER 6 - Function parameter list

| Classify | Parameter number | Function | Setting range | Unit | Factory Value |
|--------------------------|------------------|--------------------------|---|------|---------------|
| 01: System configuration | P01.11 | Parameter operation | 0: Normal Operation; 1: Parameter Initialization, initialization parameters other than P01.XX; 2: Initialize all parameters | | 0 |
| | P01.13 | Set keyword | 0~9999 | | 0 |
| | P01.14 | Set keyword confirmed | 0~9999 | | 0 |
| | P01.15 | Input keyword | 0~9999 | | 0 |
| | P01.19 | Parameter page number | 0~4 | | 0 |
| | P01.20 | Macro-program | 0~9999 | | 0 |
| | P01.21 | Recipe | 0~10000 | | 0 |
| | P01.30 | Set virtual terminal | 0~199:Value setting; 200~9999:Address | | 0 |
| | P01.32 | Virtual address 1 | 0~4294967295 | | 0 |
| | P01.33 | Virtual address 2 | 0~4294967295 | | 0 |
| | P01.34 | Virtual address 3 | 0~4294967295 | | 0 |
| | P01.35 | Virtual address 4 | 0~4294967295 | | 0 |
| | P01.36 | Virtual address 5 | 0~4294967295 | | 0 |
| | P01.37 | Virtual address 6 | 0~4294967295 | | 0 |
| | P01.38 | Virtual address 7 | 0~4294967295 | | 0 |
| | P01.39 | Command mode | 0:Single Command source mode; 1:Multi-command source mode | | 0 |
| | P01.40 | Communication protocol | 0:Reserved; 1:MODBUS RTU; 2~6:Reserved | | 1 |
| | P01.41 | Address | 0~247 | | 1 |
| | P01.42 | Baud rate | 0: 2400; 1: 4800; 2: 9600; 3: 19200; 4: 38400; 5~10: Reserved | bps | 3 |
| | P01.43 | Parity check | 0:No Check; 1:Even check; 2:Odd check | | 0 |
| | P01.44 | Data bit | 7~8 | bit | 8 |
| | P01.45 | Stop bit | 0.0~2.0 | bit | 1.0 |
| | P01.46 | Communication delay time | 0~100 | | 3 |
| | P01.47 | Parameter decimal mode | 0~123 | | 0 |
| | P01.63 | Keyboard settings source | 0: Keyboard numeric setting (P02.92); 1: Keyboard potentiometer setting | | 1 |

| Classify | Parameter number | Function | Setting range | Unit | Factory Value |
|-----------------|-------------------------------|--------------------------------------|---|------|---------------|
| | P01.66 | Keyboard M light source | 0: Always 0; 1: Always 1; 2: Stopped; 3: Running; 4: Fault; 5: Warning; 6: Reversing; 7: Ready; 64: STO state; 100 ~ 9999: Address | | 5 |
| | P01.67 | Keyboard M light source bit | 0~31 | | 0 |
| | P01.68 | Display value 1 source | 0~9999 | | 1011 |
| | P01.69 | Display value 2 source | 0~9999 | | 1091 |
| 02: set channel | P02.00 | Multi-speed source | 0~11111111 Units: S1; | | 0 |
| | P02.01 | Source of acceleration time | Tens: S2; | | 0 |
| | P02.02 | Source of deceleration time | Hundreds: S3; ... | | 0 |
| | P02.03 | Source of incremental command (UP) | Units: Keyboard; Tens: Communication; Hundreds: S1; | | 0 |
| | P02.04 | Source of decrement command (DOWN) | Thousands: S2; ... | | 0 |
| | P02.10 | Set value source 1 | 0: Keyboard; 1: Multi-speed; | | 0 |
| | P02.11 | Set value source 2 | 2: AI1; 3: AI2; | | 0 |
| | P02.12 | Set value source 3 | 5: Communication; 9: Pulse input; 200 ~ 9999: Address | | 0 |
| | P02.13 | Set channel 1 relationship selection | 0:F1; 1:F2; 2:F1+F2; 3:F1-F2; 4:F1*F2/100; | | 0 |
| | P02.14 | Set channel 2 relationship selection | 5:Maximum value(F1,F2); 6:Minimum value(F1,F2) ; 7:Average value(F1,F2) ; 8:PID(F1,F2) | | 0 |
| | P02.18 | Maximum setting value | | | 50.000 |
| | P02.19 | Minimum setting value | 0.000~99999.000 | | 0.000 |
| | P02.20 | Avoid-frequency 1 start point | | | |
| | P02.21 | Avoid-frequency 1 stop point | | | |
| P02.22 | Avoid-frequency 2 start point | | | | |
| P02.23 | Avoid-frequency 2 stop point | | | | |
| P02.24 | JOG frequency | -1000.000~1000.000 | | % | 10.000 |

Function parameter list

| Classify | Parameter number | Function | Setting range | Unit | Factory Value |
|-----------------|-----------------------------|--|---|------|---------------|
| 02: set channel | P02.26 | Increase and decrease (UP / DOWN) Step-frequency | -100.0~100.0 | % | 0.2 |
| | P02.27 | Increase and decrease (UP / DOWN) memory selection | 0: No memory; 1: Only power down memory; 2: Only stop memory; 3: Both power down and stop memory | | 3 |
| | P02.28 | Speed up and down frequency | -1000.000~1000.000 | % | 0.000 |
| | P02.30 | Multi-speed 0 | | | |
| | P02.31 | Multi-speed 1 | | | |
| | P02.32 | Multi-speed 2 | | | |
| | P02.33 | Multi-speed 3 | | | |
| | P02.34 | Multi-speed 4 | | | |
| | P02.35 | Multi-speed 5 | | | |
| | P02.36 | Multi-speed 6 | | | |
| | P02.37 | Multi-speed 7 | | | |
| | P02.38 | Multi-speed 8 | | | |
| | P02.39 | Multi-speed 9 | | | |
| | P02.40 | Multi-speed 10 | | | |
| | P02.41 | Multi-speed 11 | | | |
| | P02.42 | Multi-speed 12 | | | |
| | P02.43 | Multi-speed 13 | | | |
| | P02.44 | Multi-speed 14 | | | |
| | P02.45 | Multi-speed 15 | | | |
| | P02.50 | Acceleration time 0 | | | |
| | P02.51 | Acceleration time 1 | | | |
| | P02.52 | Acceleration time 2 | | | |
| | P02.53 | Acceleration time 3 | | | |
| | P02.54 | Acceleration time 4 | | | |
| | P02.55 | Acceleration time 5 | | | |
| | P02.56 | Acceleration time 6 | | | |
| | P02.57 | Acceleration time 7 | | | |
| | P02.58 | Acceleration time 8 | | | |
| | P02.59 | Acceleration time 9 | | | |
| | P02.60 | Acceleration time 10 | | | |
| P02.61 | Acceleration time 11 | | | | |
| P02.62 | Acceleration time 12 | | | | |
| P02.63 | Acceleration time 13 | | | | |
| P02.64 | Acceleration time 14 | | | | |
| P02.65 | Acceleration time 15 | | | | |
| P02.66 | JOG acceleration time | 0.050~3600.000 | | s | 5.000 |
| P02.68 | S curve acceleration time 1 | | | | |
| P02.69 | S curve acceleration time 2 | | | | |

Function parameter list

| Classify | Parameter number | Function | Setting range | Unit | Factory Value |
|----------------------|----------------------|--|---|------|---------------|
| 02: set channel | P02.70 | Deceleration time 0 | 0.050~3600.000 | s | * |
| | P02.71 | Deceleration time 1 | | | |
| | P02.72 | Deceleration time 2 | | | |
| | P02.73 | Deceleration time 3 | | | |
| | P02.74 | Deceleration time 4 | | | |
| | P02.75 | Deceleration time 5 | | | |
| | P02.76 | Deceleration time 6 | | | |
| | P02.77 | Deceleration time 7 | | | |
| | P02.78 | Deceleration time 8 | | | |
| | P02.79 | Deceleration time 9 | | | |
| | P02.80 | Deceleration time 10 | | | |
| | P02.81 | Deceleration time 11 | | | |
| | P02.82 | Deceleration time 12 | | | |
| | P02.83 | Deceleration time 13 | | | |
| | P02.84 | Deceleration time 14 | | | |
| P02.85 | Deceleration time 15 | | | | |
| 03: Input and output | P02.86 | Jog deceleration time | 0.050~3600.000 | s | 5.000 |
| | P02.87 | Safe deceleration time | 0.050~3600.000 | s | 5.000 |
| | P02.88 | S curve deceleration time 1 | 0.000~100.000 | % | 0.000 |
| | P02.89 | S curve deceleration time 2 | 0.000~100.000 | % | 0.000 |
| | P02.90 | Communication set value | -1000.000~1000.000 | % | 0.000 |
| | P02.91 | Communication command | 0~4294967295 | | 0 |
| | P02.92 | Keyboard set value | -1000.000~1000.000 | % | 100.000 |
| | P02.93 | Keyboard command | 0~4294967295 | | 0 |
| | P03.00 | Start command source | 0 ~ 4294967295 | | 1 |
| | P03.01 | Reverse start command source | Single command source mode (P01.39 = 0): 0: No effect; 1: Keyboard; | | 0 |
| | P03.02 | Reverse command source | 2: Communication; 3: S1; 4: S2; | | 0 |
| | P03.03 | JOG command source | ... | | 1 |
| | P03.04 | Stop command source | 17 ~ 32: The 0 ~ 15 bits of P01.30 | | 0 |
| | P03.05 | Free parking command source | ... | | 0 |
| | P03.06 | Safe stop command source | Multi-command source mode (P01.39 = 1): bit0: Keyboard; | | 0 |
| P03.07 | Reset command source | bit1: Communication; | | 1 | |
| P03.08 | Fault command source | bit2: S1; bit3: S2; | | 0 | |
| P03.09 | Pause command source | ... bit16~bit31:The 0~15 bit of P01.30 | | 0 | |
| P03.20 | S1 type | One place: 0: Positive logic; 1: Reverse logic; 2: Rising edge; 3: Falling edge Tens place: 1: Rising edge toggle; 2: Falling edge toggle Hundreds place: 1: The edge signal is not cleared by other edge signals Thousands place: 1: The edge signal is not cleared by the stop signal | | 0 | |
| P03.21 | S2 type | | | | |
| P03.22 | S3 type | | | | |
| P03.23 | S4 type | | | | |
| P03.24 | S5 type | | | | |
| P03.25 | S6 type | | | | |
| P03.26 | S7 type | | | | |
| P03.27 | S8 type | | | | |

| Classify | Parameter number | Function | Setting range | Unit | Factory Value |
|----------------------|-------------------------------|--|--|---------|---------------|
| 03: Input and output | P03.28 | S Input filtering | 1~16 | | 4 |
| | P03.29 | Start signal enable mode | 0: Always enabled; 1: Need to re-enable after power on; 2: Need to re-enable after free stop or safe stop; 3: Need to re-enable after power-on, free stop or safe stop. | | 0 |
| | P03.30 | Y1 terminal source (RA、RB、RC or RA1、RB1、RC1) | 0: Always 0; 1: Always 1; 2: Stopped; 3: Running; 4: Fault; 5: Warning; 6: Reversing; 7: Ready; 64: STO state; 100 ~ 9999: Address | | 3 |
| | P03.31 | Y1 terminal source bit | 0~31 | | 0 |
| | P03.32 | Y2 terminal source (RA2、RB2、RC2) | 0: Always 0; 1: Always 1; 2: Stopped; 3: Running; 4: Fault; 5: Warning; 6: Reversing; 7: Ready; 64: STO state; 100 ~ 9999: Address | | 4 |
| | P03.33 | Y2 terminal source bit | 0~31 | | 0 |
| | P03.34 | Y3 terminal source (RA3、RB3、RC3) | 0: Always 0; 1: Always 1; 2: Stopped; 3: Running; 4: Fault; 5: Warning; 6: Reversing; 7: Ready; 64: STO state; 100 ~ 9999: Address | | 5 |
| | P03.35 | Y3 terminal source bit | 0~31 | | 0 |
| | P03.36 | Y1 output delay time | 0.000~6000.000 | s | 0.000 |
| | P03.37 | Y2 output delay time | | | |
| | P03.38 | Y3 output delay time | | | |
| | P03.39 | A1 filter time | 0.100~600.000 | s | 0.100 |
| | P03.40 | A1 signal type | 0: Voltage input; 1: Current input | | 0 |
| | P03.41 | A1 low-end voltage (current) | -999999.000~999999.000 | V(mA) | 0.000 |
| | P03.42 | A1 high-end voltage (current) | | | 10.000 |
| P03.43 | A1 low-end setting | -999999.000~999999.000 | % | 0.000 | |
| P03.44 | A1 high-end setting | | | 100.000 | |
| P03.45 | A2 signal type | 0: Voltage input; 1: Current input | | 0 | |
| P03.46 | A2 low-end voltage (current) | -999999.000~999999.000 | V(mA) | 0.000 | |
| P03.47 | A2 high-end voltage (current) | | | 10.000 | |
| P03.48 | A2 low-end setting | -999999.000~999999.000 | % | 0.000 | |
| P03.49 | A2 high-end setting | | | 100.000 | |

Function parameter list

Function parameter list

| Classify | Parameter number | Function | Setting range | Unit | Factory Value |
|----------------------|------------------|----------------------------------|---|--------|---------------|
| 03: Input and output | P03.60 | AO1 signal type | 0: Voltage output; 1: Current output | | 0 |
| | P03.61 | AO1 signal source | 0: Always 0; 1: Always 10V / 20mA; 2: Output frequency; 3: Motor current; 4: Output voltage; 5: Motor torque; 6: Output power; 7: Set frequency; 100~999: Refer to the value of parameter numberr | | 2 |
| | P03.62 | AO1 low-end setting | -999999.000~999999.000 | | 0.000 |
| | P03.63 | AO1 high-end setting | | 50.000 | |
| | P03.64 | AO1 low-end voltage (current) | -999999.000~999999.000 | V(mA) | 0.000 |
| | P03.65 | AO1 high-end voltage (current) | | | 10.000 |
| | P03.66 | AO2 signal type | 0: Voltage output; 1: Current output | | 0 |
| | P03.67 | AO2 signal source | 0: Always 0; 1: Always 10V / 20mA; 2: Output frequency; 3: Motor current; 4: Output voltage; 5: Motor torque; 6: Output power; 7: Set frequency; 100~999: Refer to the value of parameter numberr | | 3 |
| | P03.68 | AO2 low-end setting | -999999.000~999999.000 | | 0.000 |
| | P03.69 | AO2 high-end setting | | 50.000 | |
| | P03.70 | AO2 low-end voltage (current) | -999999.000~999999.000 | V(mA) | 0.000 |
| | P03.71 | AO2 high-end voltage (current) | | | 10.000 |
| 04: PID control | P04.00 | PID proportional gain | 0.000~10.000 | % | 0.010 |
| | P04.01 | PID integration time | 0.001~9999.000 | s | 10.000 |
| | P04.02 | PID differential gain | 0.000~9999.000 | % | 0.000 |
| | P04.03 | PID forward feedback coefficient | 0~500 | % | 0 |
| | P04.04 | PID sampling time | 0.001~9999.000 | s | 0.004 |
| | P04.05 | PID output upper limit | -1000.000~1000.000 | % | 100.000 |
| | P04.06 | PID output lower limit | | 0.000 | |
| | P04.07 | PID output filter time | 0.000~600.000 | s | 0.000 |
| | P04.09 | PID range | 0.001~99999.000 | | 100.000 |
| | P04.11 | PID sleep frequency | 0.000~500.000 | % | 0.000 |
| | P04.12 | PID enter sleep time | 0.000~3600.000 | s | 0.000 |
| | P04.13 | PID wake-up deviation | 0.000~100.000 | % | 0.000 |
| | P04.14 | PID enter wake-up time | 0.000~3600.000 | s | 0.000 |
| | P04.15 | PID sleep action | 0: Do not sleep; 1: PID stop; 2: Decelerate to stop; 3: Free to stop; 4: Pause; 5: Lowest frequency operation | | 0 |
| | P04.90 | PID status | 0~4294967295 | | |

| Classify | Parameter number | Function | Setting range | Unit | Factory Value |
|--------------------|------------------|---|---|------|---------------|
| 05: System control | P05.00 | Control mode | 0: VF; 1: Open loop vector 1 | | 1 |
| | P05.06 | Forward and reverse switching time | 0.000~6000.000 | s | 0.000 |
| | P05.07 | Forced change direction | 0: No effect; 1: Forced change direction | | 0 |
| | P05.08 | Motor frequency upper limit | -1020.000~1020.000 | Hz | 55.000 |
| | P05.10 | start-up function | 0: When the time of P05.11 is over, frequency start by pressing P05.12; 1: On speed start; 2: DC injection 3: Run at the frequency of P05.12 within the time of P05.11 | | 0 |
| | P05.11 | Start time | 0.000~60000.000 | s | 0.000 |
| | P05.12 | Start frequency | 0.000~100.000 | Hz | 0.000 |
| | P05.14 | On speed start mode | 0: All directional; 1: Set value direction; 2 ~ 3: Reserved | | 0 |
| | P05.19 | DC injection current | 0.000~200.000 | % | 100.000 |
| | P05.20 | Stop function | Units: 0: Free parking; 1: DC braking; Ten: 1: Precise parking | | 0 |
| | P05.21 | Stop frequency | 0.000~1000.000 | Hz | 0.000 |
| | P05.22 | DC braking | 0.000~300.000 | % | 100.000 |
| | P05.23 | DC braking time | 0.000~1000.000 | s | 0.000 |
| | P05.24 | Demagnetization time ratio | 0.000~1000.000 | % | 10.000 |
| | P05.26 | Magnetic flux brake activation frequency | 0.000~1000.000 | Hz | 0.000 |
| | P05.27 | Magnetic flux braking coefficient | 100~200 | % | 100 |
| | P05.28 | Magnetic flux braking time | 0.000~1000.000 | s | 0.000 |
| | P05.30 | Brake resistance mode | 0: Invalid; 1: Maximum duty cycle | | 1 |
| | P05.50 | Auto reset mode | 0~9999 | | 0 |
| | P05.51 | Auto reset time | 0.000~600.000 | s | 10.000 |
| | P05.60 | Auto energy saving minimum magnetic flux | 30~100 | % | 100 |
| | P05.61 | Auto energy saving start frequency | 0.000~200.000 | Hz | 5.000 |
| | P05.63 | Manual energy saving magnetic flux | 30~90 | % | 70 |
| | P05.71 | Current upper limit | 0~300 | % | 150 |
| | P05.76 | Upper limit of electric torque | 0.000~900.00 | % | 150.000 |
| | P05.77 | Upper limit of regenerative torque | 0.000~900.000 | % | 150.000 |
| | P05.80 | Over-voltage control | 0: Invalid; 1: Valid at all times | | 1 |
| | P05.82 | Over-voltage control scale coefficient | 0~200 | % | 100 |
| | P05.83 | Over-voltage control integral coefficient | 1~10000 | % | 100 |

Function parameter list

Function parameter list

| Classify | Parameter number | Function | Setting range | Unit | Factory Value |
|--------------------|--|---|---|--------|---------------|
| 05: System control | P05.85 | Under-voltage control | Units: grid power-down action mode 0: Invalid; 1: Instantaneous stop no stop; 2: Safe parking; 3 ~ 6: Reserved Tens: under-voltage action mode of power grid 0: Invalid; 1: Safe frequency reduction | | 0 |
| | P05.86 | Power grid voltage level | 100~800 | V | * |
| | P05.90 | AVR function selection | 0: Invalid; 1: Valid; 2: Only invalid when decelerating | | 1 |
| | P05.91 | AVR function damping factor | 0~100 | % | 100 |
| 06: Motor model | P06.00 | Motor parameter self-learning | 0: Invalid 1: Complete self-learning 2: Simple self-learning | | 0 |
| | P06.05 | Carrier frequency | 2~16 | kHz | * |
| | P06.06 | Over-modulation function | 0: Invalid; 1: Valid | | 1 |
| | P06.10 | Motor type | 0: Asynchronous motor; 1: Surface mount permanent magnet synchronization; 2: Salient pole permanent magnet synchronization 4: Single-phase motor | | 0 |
| | P06.11 | Motor rated Power | 0.000~100000.000 | kW | * |
| | P06.12 | Motor rated voltage | 0~1000 | V | * |
| | P06.13 | Motor rated frequency | 1~3000 | Hz | * |
| | P06.14 | Motor rated current | 0.00~1000.00 | A | * |
| | P06.15 | Motor rated speed | 10~65535 | rpm | * |
| | P06.16 | Motor power factor | 0.00~1.00 | | * |
| | P06.17 | Number of motor poles | 2~100 | | * |
| | P06.18 | Motor rated torque | 0.1~10000.0 | N·m | * |
| | P06.19 | Motor no-load current | 0.00~1000.00 | A | * |
| | P06.20 | PM motor back EMF/rev | 1.000~10000.000 | mV/rpm | * |
| | P06.40 | Stator impedance | 0.000~99.990 | Ω | * |
| | P06.41 | Rotor impedance | 0.000~99.990 | Ω | * |
| | P06.42 | Stator leakage reactance | 0.000~999.990 | mH | * |
| | P06.44 | Motor main reactance | 0.00~999.90 | mH | * |
| | P06.50 | PM d-axis reactance | 0.000~1000.000 | mH | * |
| | P06.51 | PM q-axis reactance | 0.001~9999.000 | mH | * |
| P06.52 | PM d-axis reactance saturation coefficient | 0.0~100.0 | % | * | |
| P06.53 | PM q-axis reactance saturation coefficient | 0.0~100.0 | % | * | |
| P06.54 | Maximum field weakening current d | 10~400 | % | 100 | |
| P06.55 | Maximum field weakening current q | 10~400 | % | 100 | |
| P06.60 | Single-phase motor turns ratio | 0.200~1.800 | | 1.000 | |
| P06.70 | Load type | 0: Constant torque; 1: Fan water pump; 2: Promotion; 3: Reserved | | 0 | |
| P06.80 | Motor cable compensation strength | 0~500 | | 0 | |

| Classify | Parameter number | Function | Setting range | Unit | Factory Value |
|-----------------------|----------------------|--|--|------|---------------|
| 07: Control algorithm | P07.50 | Slip compensation | -500~500 | % | 100 |
| | P07.51 | Slip compensation filter constant | 1~10000 | % | 100 |
| | P07.52 | Resonance suppression coefficient | 0~10000 | % | 100 |
| | P07.53 | Low-speed suppression filter constant | 1~10000 | % | 100 |
| | P07.54 | High-speed suppression filter constant | 1~10000 | % | 100 |
| | P07.55 | Automatic torque boost coefficient | 0~300 | % | 100 |
| | P07.57 | Low speed minimum current | 0~300 | % | 50 |
| | P07.58 | Static friction lift coefficient | 0~10000 | % | 100 |
| | P07.59 | Static friction lift time | 0.0~1000.0 | s | 0.0 |
| | P07.71 | VF curve-F1 | 0.0~3000.0 | Hz | 50.0 |
| | P07.72 | VF curve-F2 | | | 50.0 |
| | P07.73 | VF curve-F3 | | | 50.0 |
| | P07.74 | VF curve-F4 | | | 50.0 |
| | P07.75 | VF curve-V0 | 0~10000 | V | 0 |
| P07.76 | VF curve-V1 | * | | | |
| P07.77 | VF curve-V2 | * | | | |
| P07.78 | VF curve-V3 | * | | | |
| P07.79 | VF curve-V4 | * | | | |
| 09: System protect | P09.00 | Input phase loss action | 0: Fault; 1: Alarm; 2: Invalid | | 2 |
| | P09.04 | Output phase loss detection | 0: Invalid; 1: Valid | | 1 |
| | P09.06 | ETR selection | 0: Invalid; 1: Alarm; 2: Fault | | 2 |
| | P09.49 | STO display selection | 0: STO/STO1/STO2/STO3 state is not displayed; 1: Display alarm in STO state; 2: Display fault in STO state | | 0 |
| 10: System status | P10.05 | Software version number | | | |
| | P10.10 | Control word | 0~4294967295 | | |
| | P10.11 | Set value | -65535.0~65535.0 | | |
| | P10.15 | Current state | 0~4294967295 | | |
| | P10.16 | Fault state word 1 | 0~4294967295 | | |
| | P10.17 | Fault state word 2 | 0~4294967295 | | |
| | P10.18 | Alarm state word | 0~4294967295 | | |
| | P10.20 | Output frequency absolute value | 0.0~65535.0 | Hz | |
| | P10.21 | Output frequency | -65535.0~65535.0 | Hz | |
| | P10.22 | Output current | 0.00~65535.00 | A | |
| | P10.23 | Output voltage | 0.0~65535.0 | V | |
| | P10.24 | Output torque | 0.000~65535.000 | N·m | |
| | P10.25 | DC voltage | 0.0~65535.0 | V | |
| P10.26 | Inverter temperature | 0~65535 | °C | | |
| P10.27 | Inverter hot load | 0~65535 | % | | |

Function parameter list

Function parameter list

| Classify | Parameter number | Function | Setting range | Unit | Factory Value |
|-------------------|------------------|-------------------------------------|----------------------|------|---------------|
| 10: System status | P10.28 | Motor hot load | 0~65535 | % | |
| | P10.30 | power | 0.000~65535.000 | kW | |
| | P10.31 | Energy consumption | 0.000~4294967.295 | kW*h | |
| | P10.40 | Hours of power on | 0.000~4294967.295 | h | |
| | P10.41 | Number of power-on | 0~4294967295 | | |
| | P10.44 | Communication timeout | 0.000~9999.000 | s | |
| | P10.60 | Current alarm number | 0~4294967295 | | |
| | P10.61 | Current fault number | 0~4294967295 | | |
| | P10.62 | Last fault number | 0~4294967295 | | |
| | P10.63 | The first two fault numbers | 0~4294967295 | | |
| | P10.70 | S input terminal state | 0~4294967295 | | |
| | P10.71 | AI1 terminal input value | -65535.000~65535.000 | % | |
| | P10.72 | AI2 terminal input value | -65535.000~65535.000 | % | |
| | P10.74 | Y terminal output state | 0~4294967295 | | |
| | P10.75 | AO1 terminal output value | -65535.000~65535.000 | % | |
| | P10.76 | AO2 terminal output value | -65535.000~65535.000 | % | |
| | P10.78 | Pulse input frequency | 0.000~10000.000 | kHz | |
| | P10.79 | Pulse output frequency | 0.000~10000.000 | kHz | |
| | P10.80 | Encoder count | 0~4294967295 | | |
| | P10.81 | Encoder speed | -9999.000~9999.000 | Hz | |
| P10.82 | Encoder angle | 0.0~359.9 | deg | | |
| P10.90 | Set value 1 | -999999.000~999999.000 | % | | |
| P10.91 | Set value 2 | -999999.000~999999.000 | % | | |
| P10.92 | Set value 3 | -999999.000~999999.000 | % | | |
| P10.98 | Display value 1 | -99999.000~99999.000 | | | |
| P10.99 | Display value 2 | -99999.000~99999.000 | | | |
| 11: Fault record | P11.10 | Current fault output frequency | -999999.0~999999.0 | Hz | 0.0 |
| | P11.11 | Current fault output current | -999999.00~999999.00 | A | 0.00 |
| | P11.12 | Current fault bus voltage | -999999.0~999999.0 | V | 0.0 |
| | P11.13 | Current faulty inverter temperature | -999999~999999 | ℃ | 0 |
| | P11.14 | Current fault S terminal state | -999999~999999 | | 0 |
| | P11.15 | Current fault Y terminal state | -999999~999999 | | 0 |
| | P11.16 | Accumulated power-on time | 0.000~4294967.295 | h | 0.000 |
| | P11.20 | Output frequency of last fault | -999999.0~999999.0 | Hz | 0.0 |
| | P11.21 | output current of last fault | -999999.00~999999.00 | A | 0.00 |
| | P11.22 | Bus voltage of last fault | -999999.0~999999.0 | V | 0.0 |
| | P11.23 | Inverter temperature of last fault | -999999~999999 | ℃ | 0 |
| | P11.24 | S-terminal state of last fault | -999999~999999 | | 0 |
| | P11.25 | Y terminal state of last fault | -999999~999999 | | 0 |

Function parameter list

| Classify | Parameter number | Function | Setting range | Unit | Factory Value | |
|------------------|---------------------|---|---------------------------------------|------------------------|---------------|-------|
| 11: Fault record | P11.26 | Accumulated power-on time of the last fault | 0.000~4294967.295 | h | 0.000 | |
| | P11.30 | Output frequency of the first two faults | -999999.0~999999.0 | Hz | 0.0 | |
| | P11.31 | Output current of the first two faults | -999999.00~999999.00 | A | 0.00 | |
| | P11.32 | Bus voltage of the first two faults | -999999.0~999999.0 | V | 0.0 | |
| | P11.33 | Inverter temperature of the first two faults | -999999~999999 | ℃ | 0 | |
| | P11.34 | S terminal state of the first two faults | -999999~999999 | | 0 | |
| | P11.35 | Y terminal state of the first two faults | -999999~999999 | | 0 | |
| | P11.36 | Accumulated power-on time of the first two faults | 0.000~4294967.295 | h | 0.000 | |
| | 12: Free parameter | P12.00 ~ P12.19 | Free parameter 1~ Free parameter 20 | -999999.000~999999.000 | | 0.000 |
| | | P12.90 ~ P12.99 | Free parameter 91~ Free parameter 100 | -999999.000~999999.000 | | 0.000 |
| | 13: Function output | P13.00 | Comparator output | 0~4294967295 | | 0 |
| | | P13.01 | Logic output | 0~4294967295 | | 0 |
| P13.02 | | Linear transformation 1 result | -999999.000~999999.000 | | 0.000 | |
| P13.03 | | Linear transformation 2 result | -999999.000~999999.000 | | 0.000 | |
| P13.10 | | Single arithmetic operation 1 output | -999999.000~999999.000 | | 0.000 | |
| P13.11 | | Single arithmetic operation 2 output | -999999.000~999999.000 | | 0.000 | |
| P13.12 | | Single arithmetic operation 3 output | -999999.000~999999.000 | | 0.000 | |
| P13.13 | | Single arithmetic operation 4 output | -999999.000~999999.000 | | 0.000 | |
| P13.14 | | Single arithmetic operation 5 output | -999999.000~999999.000 | | 0.000 | |
| P13.15 | | Math operation 1 output | -999999.000~999999.000 | | 0.000 | |
| P13.16 | | Math operation 2 output | -999999.000~999999.000 | | 0.000 | |
| P13.17 | | Math operation 3 output | -999999.000~999999.000 | | 0.000 | |
| P13.18 | | Math operation 4 output | -999999.000~999999.000 | | 0.000 | |
| P13.40 | | Comparator 1 output | 0~1 | | 0 | |
| P13.41 | | Comparator 2 output | 0~1 | | 0 | |
| P13.42 | | Comparator 3 output | 0~1 | | 0 | |
| P13.43 | | Comparator 4 output | 0~1 | | 0 | |
| P13.44 | | Comparator 5 output | 0~1 | | 0 | |
| P13.45 | | Comparator 6 output | 0~1 | | 0 | |
| P13.46 | | Comparator 7 output | 0~1 | | 0 | |
| P13.47 | Comparator 8 output | 0~1 | | 0 | | |
| P13.48 | Comparator 9 output | 0~1 | | 0 | | |
| P13.50 | Logic 1 output | 0~1 | | 0 | | |
| P13.51 | Logic 2 output | 0~1 | | 0 | | |

Function parameter list

| Classify | Parameter number | Function | Setting range | Unit | Factory Value |
|---------------------|-------------------------|---|--|-------|---------------|
| 13: Function output | P13.60 | Timer 1 current counting | 0~4294967295 | | 0 |
| | P13.61 | Timer 1 current value | 0~65535 | | 0 |
| | P13.62 | Timer 1 current stage | 0~16 | | 0 |
| | P13.63 | Timer 2 current counting | 0~4294967295 | | 0 |
| | P13.64 | Timer 2 current value | 0~65535 | | 0 |
| | P13.65 | Timer 2 current stage | 0~16 | | 0 |
| | P13.92 | virtual address current value 1 | 0~4294967295 | | 0 |
| | P13.93 | virtual address current value 2 | 0~4294967295 | | 0 |
| | P13.94 | virtual address current value 3 | 0~4294967295 | | 0 |
| | P13.95 | virtual address current value 4 | 0~4294967295 | | 0 |
| | P13.96 | virtual address current value 5 | 0~4294967295 | | 0 |
| | P13.97 | virtual address current value 6 | 0~4294967295 | | 0 |
| | P13.98 | virtual address current value 7 | 0~4294967295 | | 0 |
| 14: encoder | P14.01 | Encoder 1 resolution | 1~2147483647 | | 1024 |
| | P14.02 | Encoder 1 direction | 0: Forward; 1: Reverse | | 0 |
| 16: logic unit | P16.00 | Comparator 1 input parameter selection | 0~65535 | | 0 |
| | P16.01 | Comparator 1 comparison parameter selection | 0~65535 | | 0 |
| | P16.02 | Comparator 1 configuration | 0: >; 1: <; 2: >; 3: <; 4: =; 5: ≠; 6: ≠ | | 0 |
| | P16.03 | Comparator 1 delay time | 0.000~99999.000 | s | 0.000 |
| | P16.04 | Comparator 2 input parameter selection | 0~65535 | | 0 |
| | P16.05 | Comparator 2 comparison parameter selection | 0~65535 | | 0 |
| | P16.06 | Comparator 2 configuration | 0: >; 1: <; 2: >; 3: <; 4: =; 5: ≠; 6: ≠ | | 0 |
| | P16.07 | Comparator 2 delay time | 0.000~99999.000 | s | 0.000 |
| | P16.08 | Comparator 3 input parameter selection | 0~65535 | | 0 |
| | P16.09 | Comparator 3 comparison parameter selection | 0~65535 | | 0 |
| | P16.10 | Comparator 3 configuration | 0: >; 1: <; 2: >; 3: <; 4: =; 5: ≠; 6: ≠ | | 0 |
| P16.11 | Comparator 3 delay time | 0.000~99999.000 | s | 0.000 | |

| Classify | Parameter number | Function | Setting range | Unit | Factory Value |
|----------------|-------------------------|---|--|-------|---------------|
| 16: logic unit | P16.12 | Comparator 4 input parameter selection | 0~65535 | | 0 |
| | P16.13 | Comparator 4 comparison parameter selection | 0~65535 | | 0 |
| | P16.14 | Comparator 4 configuration | 0: >; 1: <; 2: >; 3: <; 4: =; 5: ≠; 6: ≠ | | 0 |
| | P16.15 | Comparator 4 delay time | 0.000~99999.000 | s | 0.000 |
| | P16.16 | Comparator 5 input parameter selection | 0~65535 | | 0 |
| | P16.17 | Comparator 5 comparison parameter selection | 0~65535 | | 0 |
| | P16.18 | Comparator 5 configuration | 0: >; 1: <; 2: >; 3: <; 4: =; 5: ≠; 6: ≠ | | 0 |
| | P16.19 | Comparator 5 delay time | 0.000~99999.000 | s | 0.000 |
| | P16.20 | Comparator 6 input parameter selection | 0~65535 | | 0 |
| | P16.21 | Comparator 6 comparison parameter selection | 0~65535 | | 0 |
| | P16.22 | Comparator 6 configuration | 0: >; 1: <; 2: >; 3: <; 4: =; 5: ≠; 6: ≠ | | 0 |
| | P16.23 | Comparator 6 delay time | 0.000~99999.000 | s | 0.000 |
| | P16.24 | Comparator 7 input parameter selection | 0~65535 | | 0 |
| | P16.25 | Comparator 7 comparison parameter selection | 0~65535 | | 0 |
| | P16.26 | Comparator 7 configuration | 0: >; 1: <; 2: >; 3: <; 4: =; 5: ≠; 6: ≠ | | 0 |
| | P16.27 | Comparator 7 delay time | 0.000~99999.000 | s | 0.000 |
| | P16.28 | Comparator 8 input parameter selection | 0~65535 | | 0 |
| | P16.29 | Comparator 8 comparison parameter selection | 0~65535 | | 0 |
| | P16.30 | Comparator 8 configuration | 0: >; 1: <; 2: >; 3: <; 4: =; 5: ≠; 6: ≠ | | 0 |
| P16.31 | Comparator 8 delay time | 0.000~99999.000 | s | 0.000 | |

Function parameter list

Function parameter list

| Classify | Parameter number | Function | Setting range | Unit | Factory Value |
|----------------|------------------|---|---|------|---------------|
| 16: Logic unit | P16.32 | Comparator 9 input parameter selection | 0~65535 | | 0 |
| | P16.33 | Comparator 9 comparison parameter selection | 0~65535 | | 0 |
| | P16.34 | Comparator 9 configuration | 0: >; 1: <; 2: ≥; 3: ≤; 4: =; 5: ≠; 6: ≠ | | 0 |
| | P16.35 | Comparator 9 delay time | 0.000~99999.000 | s | 0.000 |
| | P16.36 | Logic unit 1 parameter selection 1 | 0~65535 | | 0 |
| | P16.37 | Logic unit 1 input bit selection 1 | 0~32 | | 0 |
| | P16.38 | Logic unit 1 parameter selection 2 | 0~65535 | | 0 |
| | P16.39 | Logic unit 1 input bit selection 2 | 0~32 | | 0 |
| | P16.40 | Logic unit 1 parameter selection 3 | 0~65535 | | 0 |
| | P16.41 | Logic unit 1 input bit selection 3 | 0~32 | | 0 |
| | P16.42 | Logical unit 1 configuration 1 | 0: No effect; 1: And; 2: OR; 3: NAND; 4: NOR; 5: XOR | | 0 |
| | P16.43 | Logical unit 1 configuration 2 | 0: No effect; 1: And; 2: OR; 3: NAND; 4: NOR; 5: XOR | | 0 |
| | P16.44 | Logic unit 2 parameter selection 1 | 0~65535 | | 0 |
| | P16.45 | Logic unit 2 input bit selection 1 | 0~32 | | 0 |
| | P16.46 | Logic unit 2 parameter selection 2 | 0~65535 | | 0 |
| | P16.47 | Logic unit 2 input bit selection 2 | 0~32 | | 0 |
| | P16.48 | Logic unit 2 parameter selection 3 | 0~65535 | | 0 |
| | P16.49 | Logic unit 2 input bit selection 3 | 0~32 | | 0 |
| | P16.50 | Logical unit 2 configuration 1 | 0: No effect; 1: And; 2: OR; 3: NAND; 4: NOR; 5: XOR | | 0 |
| | P16.51 | Logical unit 2 configuration 2 | 0: No effect; 1: And; 2: OR; 3: NAND; 4: NOR; 5: XOR | | 0 |

| Classify | Parameter number | Function | Setting range | Unit | Factory Value |
|-----------------------------|--|--|--|------|---------------|
| 16: Logic unit | P16.76 | Selector 1 parameter source | 0~65535 | | 0 |
| | P16.77 | Selector 1 setting | 0~16: numerical setting; 200~65535: address | | 0 |
| | P16.78 | Selector 1 destination parameters | 0~65535 | | 0 |
| | P16.79 | Selector 2 parameter source | 0~65535 | | 0 |
| | P16.80 | Selector 2 setting | 0~16: numerical setting; 200~65535: address | | 0 |
| | P16.81 | Selector 2 destination parameters | 0~65535 | | 0 |
| | P16.82 | Selector 3 parameter source | 0~65535 | | 0 |
| | P16.83 | Selector 3 setting | 0~16: numerical setting; 200~65535: address | | 0 |
| | P16.84 | Selector 3 destination parameters | 0~65535 | | 0 |
| | P16.85 | Selector 4 parameter source | 0~65535 | | 0 |
| | P16.86 | Selector 4 setting | 0~16: numerical setting; 200~65535: address | | 0 |
| | P16.87 | Selector 4 destination parameters | 0~65535 | | 0 |
| | P16.88 | Selector 5 parameter source | 0~65535 | | 0 |
| | P16.89 | Selector 5 setting | 0~16: numerical setting; 200~65535: address | | 0 |
| | P16.90 | Selector 5 destination parameters | 0~65535 | | 0 |
| | P16.91 | Selector 6 parameter source | 0~65535 | | 0 |
| | P16.92 | Selector 6 setting | 0~16: numerical setting; 200~65535: address | | 0 |
| | P16.93 | Selector 6 destination parameters | 0~65535 | | 0 |
| | P16.94 | Selector 7 parameter source | 0~65535 | | 0 |
| P16.95 | Selector 7 setting | 0~16: numerical setting; 200~65535: address | | 0 | |
| P16.96 | Selector 7 destination parameters | 0~65535 | | 0 | |
| P16.97 | Selector 8 parameter source | 0~65535 | | 0 | |
| P16.98 | Selector 8 setting | 0~16: numerical setting; 200~65535: address | | 0 | |
| P16.99 | Selector 8 destination parameters | 0~65535 | | 0 | |
| 17: Mathematical operations | P17.00 | Linear transformation 1 parameter source | 0~65535 | | 0 |
| | P17.01 | Linear transformation 1 X1 | -999999.000~999999.000 | | 0.000 |
| | P17.02 | Linear transformation 1 X2 | -999999.000~999999.000 | | 50.000 |
| | P17.03 | Linear transformation 1 Y1 | -999999.000~999999.000 | | 0.000 |
| | P17.04 | Linear transformation 1 Y2 | -999999.000~999999.000 | | 1500.000 |
| P17.05 | Linear transformation 2 parameter source | 0~65535 | | 0 | |

| Classify | Parameter number | Function | Setting range | Unit | Factory Value |
|-----------------------------|------------------|---|---|------|---------------|
| 17: Mathematical operations | P17.06 | Linear transformation 2 X1 | -999999.000~999999.000 | | 0.000 |
| | P17.07 | Linear transformation 2 X2 | -999999.000~999999.000 | | 0.000 |
| | P17.08 | Linear transformation 2 Y1 | -999999.000~999999.000 | | 0.000 |
| | P17.09 | Linear transformation 2 Y2 | -999999.000~999999.000 | | 0.000 |
| | P17.16 | Single arithmetic operation 1 parameter source | 0~65535 | | 0 |
| | P17.17 | Single arithmetic operation 1 operation setting | 0: ABS; 1: Sqrt; 2: Sin; 3: Cos; 4: Power2; 5: Power3; 6: Random; 7: Bitwise NOT; 8: 2 to the n; 10: If less than 0, it means 0. If greater than 0, unchanged; 11: If greater than 0, it means 0. If less than 0, unchanged | | 0 |
| | P17.18 | Single arithmetic operation 2 parameter source | 0~65535 | | 0 |
| | P17.19 | Single arithmetic operation 2 operation setting | 0: ABS; 1: Sqrt; 2: Sin; 3: Cos; 4: Power2; 5: Power3; 6: Random; 7: Bitwise NOT; 8: 2 to the n; 10: If less than 0, it means 0. If greater than 0, unchanged; 11: If greater than 0, it means 0. If less than 0, unchanged | | 0 |
| | P17.20 | Single arithmetic operation 3 parameter source | 0~65535 | | 0 |
| | P17.21 | Single arithmetic operation 3 operation setting | 0: ABS; 1: Sqrt; 2: Sin; 3: Cos; 4: Power2; 5: Power3; 6: Random; 7: Bitwise NOT; 8: 2 to the n; 10: If less than 0, it means 0. If greater than 0, unchanged; 11: If greater than 0, it means 0. If less than 0, unchanged | | 0 |
| | P17.22 | Single arithmetic operation 4 parameter source | 0~65535 | | 0 |
| | P17.23 | Single arithmetic operation 4 operation setting | 0: ABS; 1: Sqrt; 2: Sin; 3: Cos; 4: Power2; 5: Power3; 6: Random; 7: Bitwise NOT; 8: 2 to the n; 10: If less than 0, it means 0. If greater than 0, unchanged; 11: If greater than 0, it means 0. If less than 0, unchanged | | 0 |

Function parameter list

| Classify | Parameter number | Function | Setting range | Unit | Factory Value |
|-----------------------------|------------------|---|---|------|---------------|
| 17: Mathematical operations | P17.24 | Single arithmetic operation 5 parameter source | 0~65535 | | 0 |
| | P17.25 | Single arithmetic operation 5 operation setting | 0: ABS; 1: Sqrt; 2: Sin; 3: Cos; 4: Power2; 5: Power3; 6: Random; 7: Bitwise NOT; 8: 2 to the n; 10: If less than 0, it means 0. If greater than 0, unchanged; 11: If greater than 0, it means 0. If less than 0, unchanged | | 0 |
| | P17.26 | Mathematical operation 1 parameter source 1 | 0~65535 | | 0 |
| | P17.27 | Mathematical operation 1 parameter source 2 | 0~65535 | | 0 |
| | P17.28 | Mathematical operation 1 parameter source 3 | 0~65535 | | 0 |
| | P17.29 | Math operation 1 operation setting 1 | 0:No effect; 1:+; 2:-; 3:*; 4:/; 5:Max; 6:Min; 7:Mean; 9:Bitwise AND; 10:Bitwise OR; 11:ANDN; 15:Edge signal source; 16:Rearrange the values and increase 8 bits | | 0 |
| | P17.30 | Math operation 1 operation setting 2 | 0:No effect; 1:+; 2:-; 3:*; 4:/; 5:Max; 6:Min; 7:Mean; 9:Bitwise AND; 10:Bitwise OR; 11:ANDN; 15:Edge signal reset; 16:Rearrange the values and decrease 8 bits | | 0 |
| | P17.31 | Mathematical operation 2 parameter source 1 | 0~65535 | | 0 |
| | P17.32 | Mathematical operation 2 parameter source 2 | 0~65535 | | 0 |
| | P17.33 | Mathematical operation 2 parameter source 3 | 0~65535 | | 0 |

Function parameter list

| Classify | Parameter number | Function | Setting range | Unit | Factory Value |
|-----------------------------|------------------|---|--|------|---------------|
| 17: Mathematical operations | P17.34 | Math operation 2 operation setting 1 | 0:No effect; 1:+; 2:-; 3:*; 4:/; 5:Max; 6:Min; 7:Mean; 9:Bitwise AND; 10:Bitwise OR; 11:ANDN; 15:Edge signal source; 16:Rearrange the values and increase 8 bits | | 0 |
| | P17.35 | Math operation 2 operation setting 2 | 0:No effect; 1:+; 2:-; 3:*; 4:/; 5:Max; 6:Min; 7:Mean; 9:Bitwise AND; 10:Bitwise OR; 11:ANDN; 15:Edge signal reset; 16:Rearrange the values and decrease 8 bits | | 0 |
| | P17.36 | Mathematical operation 3 parameter source 1 | 0~65535 | | 0 |
| | P17.37 | Mathematical operation 3 parameter source 2 | 0~65535 | | 0 |
| | P17.38 | Mathematical operation 3 parameter source 3 | 0~65535 | | 0 |
| | P17.39 | Math operation 3 operation setting 1 | 0:No effect; 1:+; 2:-; 3:*; 4:/; 5:Max; 6:Min; 7:Mean; 9:Bitwise AND; 10:Bitwise OR; 11:ANDN; 15:Edge signal source; 16:Rearrange the values and increase 8 bits | | 0 |
| | P17.40 | Math operation 3 operation setting 2 | 0:No effect; 1:+; 2:-; 3:*; 4:/; 5:Max; 6:Min; 7:Mean; 9:Bitwise AND; 10:Bitwise OR; 11:ANDN; 15:Edge signal reset; 16:Rearrange the values and decrease 8 bits | | 0 |
| | P17.41 | Mathematical operation 4 parameter source 1 | 0~65535 | | 0 |
| | P17.42 | Mathematical operation 4 parameter source 2 | 0~65535 | | 0 |
| | P17.43 | Mathematical operation 4 parameter source 3 | 0~65535 | | 0 |

| Classify | Parameter number | Function | Setting range | Unit | Factory Value |
|-----------------------------|----------------------|--------------------------------------|---|------|---------------|
| 17: Mathematical operations | P17.44 | Math operation 4 operation setting 1 | 0:No effect; 1:+; 2:-; 3:*; 4:/; 5:Max; 6:Min; 7:Mean; 9:Bitwise AND; 10:Bitwise OR; 11:ANDN; 15:Edge signal source; 16:Rearrange the values and increase 8 bits | | 0 |
| | P17.45 | Math operation 4 operation setting 2 | 0:No effect; 1:+; 2:-; 3:*; 4:/; 5:Max; 6:Min; 7:Mean; 9:Bitwise AND; 10:Bitwise OR; 11:ANDN; 15:Edge signal reset; 16:Rearrange the values and decrease 8 bits | | 0 |
| 18: Timing control | P18.00 | Timer 1 clock source | 0:1ms; 1:10ms; 2:100ms; 3:1s; 6:1h; 7:1day; 11~26: from S1 ~ S16, when S terminal is the rising edge, count plus 1; 27~42: from the 0~15 bits of virtual terminal P01.30, when the corresponding bit is the rising edge, count plus 1; 51~76: from S1~S16, when S terminal is the falling edge, count plus 1; 77~92: from the 0~15 bits of virtual terminal P01.30, when the corresponding bit is the falling edge, count plus 1; 200~3799: address | | 0 |
| | P18.01 | Timer 1 working mode | 0: Stop at the end of a single run; 1 ~ 16: Set the start of the next cycle At the end of a single operation, the cycle starts automatically from the setting | | 0 |
| | P18.02 | Timer 1 control command | bit0: Enable; bit1: Start counting; bit2: Pause counting; bit3: Clear the counting | | 0 |
| | P18.03 | Timer 1 set value | -1~4294967295 | | -1 |
| | P18.04 | Timer 1 phase 1 time | 0~4294967295 | | 0 |
| | P18.05 | Timer 1 phase 2 time | 0~4294967295 | | 0 |
| | P18.06 | Timer 1 phase 3 time | 0~4294967295 | | 0 |
| | P18.07 | Timer 1 phase 4 time | 0~4294967295 | | 0 |
| | P18.08 | Timer 1 phase 5 time | 0~4294967295 | | 0 |
| | P18.09 | Timer 1 phase 6 time | 0~4294967295 | | 0 |
| | P18.10 | Timer 1 phase 7 time | 0~4294967295 | | 0 |
| P18.11 | Timer 1 phase 8 time | 0~4294967295 | | 0 | |

Function parameter list

Function parameter list

| Classify | Parameter number | Function | Setting range | Unit | Factory Value |
|--------------------|------------------|-------------------------|---|------|---------------|
| 18: Timing control | P18.12 | Timer 1 phase 9 time | 0~4294967295 | | 0 |
| | P18.13 | Timer 1 phase 10 time | 0~4294967295 | | 0 |
| | P18.14 | Timer 1 phase 11 time | 0~4294967295 | | 0 |
| | P18.15 | Timer 1 phase 12 time | 0~4294967295 | | 0 |
| | P18.16 | Timer 1 phase 13 time | 0~4294967295 | | 0 |
| | P18.17 | Timer 1 phase 14 time | 0~4294967295 | | 0 |
| | P18.18 | Timer 1 phase 15 time | 0~4294967295 | | 0 |
| | P18.19 | Timer 1 phase 16 time | 0~4294967295 | | 0 |
| | P18.20 | Timer 2 clock source | 0:1ms; 1:10ms; 2:100ms; 3:1s; 6:1h; 7:1day; 11~26: from S1 ~ S16, when S terminal is the rising edge, count plus 1; 27~42: from the 0~15 bits of virtual terminal P01.30, when the corresponding bit is the rising edge, count plus 1; 51~76: from S1~S16, when S terminal is the falling edge, count plus 1; 77~92: from the 0~15 bits of virtual terminal P01.30, when the corresponding bit is the falling edge, count plus 1; 200~3799: address | | 0 |
| | P18.21 | Timer 2 working mode | 0: Stop at the end of a single run; 1 ~ 16: Set the start of the next cycle At the end of a single operation, the cycle starts automatically from the setting | | 0 |
| | P18.22 | Timer 2 control command | bit0: Enable; bit1: Start counting; bit2: Pause counting; bit3: Clear counting | | 0 |
| | P18.23 | Timer 2 set value | -1~4294967295 | | -1 |
| | P18.24 | Timer 2 phase 1 time | 0~4294967295 | | 0 |
| | P18.25 | Timer 2 phase 2 time | 0~4294967295 | | 0 |
| | P18.26 | Timer 2 phase 3 time | 0~4294967295 | | 0 |
| | P18.27 | Timer 2 phase 4 time | 0~4294967295 | | 0 |
| | P18.28 | Timer 2 phase 5 time | 0~4294967295 | | 0 |
| | P18.29 | Timer 2 phase 6 time | 0~4294967295 | | 0 |
| | P18.30 | Timer 2 phase 7 time | 0~4294967295 | | 0 |
| | P18.31 | Timer 2 phase 8 time | 0~4294967295 | | 0 |
| | P18.32 | Timer 2 phase 9 time | 0~4294967295 | | 0 |
| | P18.33 | Timer 2 phase 10 time | 0~4294967295 | | 0 |
| | P18.34 | Timer 2 phase 11 time | 0~4294967295 | | 0 |
| | P18.35 | Timer 2 phase 12 time | 0~4294967295 | | 0 |
| | P18.36 | Timer 2 phase 13 time | 0~4294967295 | | 0 |
| | P18.37 | Timer 2 phase 14 time | 0~4294967295 | | 0 |
| | P18.38 | Timer 2 phase 15 time | 0~4294967295 | | 0 |
| | P18.39 | Timer 2 phase 16 time | 0~4294967295 | | 0 |

6.1 Group 01 parameters: system configuration

| Parameter number | Function | Setting range | Unit | Factory Value |
|------------------|-----------------------|---|------|---------------|
| P01.11 | Parameter operation | 0: Normal Operation; 1: Parameter Initialization, initialization parameters other than P01.XX; 2: Initialize all parameters | | 0 |
| P01.13 | Set keyword | 0~9999 | | 0 |
| P01.14 | Set keyword confirmed | 0~9999 | | 0 |
| P01.15 | Input keyword | 0~9999 | | 0 |

■ Function:Parameter operation setting

➢ Principle explanation:

Set P01.13 and P01.14 to the same non-zero number, and the set password is valid.

| Parameter number | Function | Setting range | Unit | Factory Value |
|------------------|-------------------|---------------|------|---------------|
| P01.19 | Page of parameter | 0~4 | | 0 |

■ Function: customize macro with upper computer

➢ Defining rules:

Modify P01.19 to complete page turning firstly
{parameter no. (even numbers), 4294967210}
{next parameter no. , 11 (Application macro code to be set) ,
{next parameter no. , 300(parameter no. to be modified P03.00)}
{next parameter no. , 3(setting value of P03.00)}

{parameter no. (even numbers), 4294967125} end

| Parameter number | Function | Setting range | Unit | Factory Value |
|------------------|---------------|---------------|------|---------------|
| P01.20 | Macro-program | 0~9999 | | 0 |
| P01.21 | Recipe | 0~10000 | | 0 |

■ Function: choose application macro, formula

➢ Principle explanation:

Application macro is a group of parameter Activating the corresponding application macro is same to setting the macro parameter set.

Set P01.20 to select the corresponding macro, you can select 2 macros at the same time. Each two-digit number represents a macro, thousand bit and hundred bit form a macro, and ten bit and unit form another macro. When the corresponding macro setting value of P01.20 changes, the corresponding macro configuration action is applied, and any parameters can be manually modified after the configuration is completed. For specific macro information, please refer to the application macro detailed description.A formula is a set of parameter sets, and the corresponding formula configuration action is executed every time the power is turned on and switched.

| Parameter number | Function | Setting range | Unit | Factory Value |
|------------------|----------------------|--|------|---------------|
| P01.30 | Set virtual terminal | 0~199:Value setting; 200~9999:Address | | 0 |

■ Function:set virtual terminal value

➢ Principle explanation:

The virtual terminal is used as a function extension. When set to 0 ~ 199, this value is the set value; when set to 200 ~ 9999, this setting is the address. The address is the selected parameter number, and the actual value is determined by the current value of the selected parameter number. For usage details, please refer to P03.00 ~ P03.09.

Function parameter list

Function parameter list

| Parameter number | Function | Setting range | Unit | Factory Value |
|------------------|-------------------|---------------|------|---------------|
| P01.32 | Virtual address 1 | 0~4294967295 | | 0 |
| P01.33 | Virtual address 2 | 0~4294967295 | | 0 |
| P01.34 | Virtual address 3 | 0~4294967295 | | 0 |
| P01.35 | Virtual address 4 | 0~4294967295 | | 0 |
| P01.36 | Virtual address 5 | 0~4294967295 | | 0 |
| P01.37 | Virtual address 6 | 0~4294967295 | | 0 |
| P01.38 | Virtual address 7 | 0~4294967295 | | 0 |

■ Function: set virtual communication terminal address

➤ Principle explanation:

Virtual communication address is used as function expansion. When the 16 bit communication data other than the parameter number is sent or received through the upper computer, this value is the actual address of the upper computer (the upper computer address is converted to decimal, plus 1), and the corresponding value of the virtual address refers to P13.92 ~ P13.98.

➤ For example: using BD600 inverter communication address as the upper computer to control the start, stop, setting frequency and read output frequency of H1 inverter.

BD600 communication address and data

| Communication address | Communication data |
|-----------------------|---|
| 1000H | Control command, 0001H: forward operation; 0006H: deceleration stop |
| 3000H | Setting frequency (0~10000 correspondence to 0~max. frequency) |
| 3001H | Read output frequency |

H1 parameter setting

| Parameter number | Function | Set Value |
|------------------|---|-----------|
| P01.32 | Virtual address 1 | 4097 |
| P01.33 | Virtual address 2 | 12289 |
| P01.34 | Virtual address 3 | 12290 |
| P02.10 | Set value source 1 | 5 |
| P03.00 | Start command source | 2 |
| P12.00 | Free parameter 1 | 100.000 |
| P12.02 | Free parameter 3 | 1.000 |
| P12.06 | Free parameter 7 | 16.000 |
| P12.07 | Free parameter 8 | 100.000 |
| P16.76 | Selector 1 parameter source | 1201 |
| P16.77 | Selector 1 setting | 1392 |
| P16.78 | Selector 1 destination parameters | 291 |
| P16.79 | Selector 2 parameter source | 1315 |
| P16.80 | Selector 2 setting | 0 |
| P16.81 | Selector 2 destination parameters | 290 |
| P16.82 | Selector 3 parameter source | 1316 |
| P16.83 | Selector 3 setting | 0 |
| P16.84 | Selector 3 destination parameters | 1394 |
| P17.26 | Mathematical operation 1 parameter source 1 | 1393 |
| P17.27 | Mathematical operation 1 parameter source 2 | 1200 |
| P17.29 | Math operation 1 operation setting 1 | 4 |
| P17.31 | Mathematical operation 2 parameter source 1 | 1020 |
| P17.32 | Mathematical operation 2 parameter source 2 | 127 |
| P17.34 | Math operation 2 operation setting 1 | 3 |

| Parameter number | Function | Setting range | Unit | Factory Value |
|------------------|--------------|--|------|---------------|
| P01.39 | Command Mode | 0:Single Command source mode; 1:Multi-command source mode | | 0 |

■ Function:Select command mode

➤ Principle explanation:

The command mode determines the command source . The single-command source mode specifies one source with an index number, and the multi-command source mode can specify multiple sources in binary. For usage details, please refer to P03.00 ~ P03.09.

| Parameter number | Function | Setting range | Unit | Factory Value |
|------------------|------------------------|--|------|---------------|
| P01.40 | Communication protocol | 0:Reserved; 1:MODBUS RTU; 2~6:Reserved | | 1 |

■ Function:Select communication protocol (only supports MOUDBUS RTU)

| Parameter number | Function | Setting range | Unit | Factory Value |
|------------------|----------|---------------|------|---------------|
| P01.41 | Address | 0~247 | | 1 |

■ Function:Set the local address of the inverter

| Parameter number | Function | Setting range | Unit | Factory Value |
|------------------|--------------|--|------|---------------|
| P01.42 | Baud rate | 0: 2400; 1: 4800; 2: 9600; 3: 19200; 4: 38400; 5~10: Reserved | bps | 3 |
| P01.43 | Parity check | 0:No Check; 1:Even check; 2:Odd check | | 0 |
| P01.44 | Data bit | 7~8 | bits | 8 |
| P01.45 | Stop bit | 0.0~2.0 | bit | 1.0 |

■ Function:Functional port configuration

| Parameter number | Function | Setting range | Unit | Factory Value |
|------------------|--------------------------|---------------|------|---------------|
| P01.46 | Communication delay time | 0~100 | ms | 3 |

■ Function:Set communication delay time, and suggest upper computer communication timeout setting range: 200ms-1000ms

| Parameter number | Function | Setting range | Unit | Factory Value |
|------------------|------------------------|---------------|------|---------------|
| P01.47 | parameter decimal mode | 0~123 | | 0 |

■ Function:select command mode

➤ Principle explanation:

The parameter decimal point mode only affects communication, changes the parameter value during communication.

➤ P01.47's unit place are for the parameters of three decimal places:

0: the decimal place remains unchanged, 1: the decimal place becomes two, 2: the decimal place becomes one, 3: becomes no decimal place.

➤ The ten place of P01.47 are for the parameters of two decimal places:

0: the decimal place remains unchanged, 1: the decimal place becomes one, 2: becomes no decimal place.

➤ P01.47's hundred place are for one decimal place parameter:

0: decimal place remains unchanged, 1: becomes no decimal place.

➤ For example: P02.51=30.000s when P01.47=000 serial port read data=30000; when P01.47=001 serial port read data=3000; when P01.47=002 serial port read data=300; when P01.47=003 serial port reading data=30.

➤ For example: P06.44=43.66 when P01.47=000 serial port read data=4366; when P01.47=010 serial port read data=436; when P01.47=020 serial port read data=43

| Parameter number | Function | Setting range | Unit | Factory Value |
|------------------|--------------------------|--|------|---------------|
| P01.63 | Keyboard settings source | 0: Keyboard numeric setting (P02.92); 1: Keyboard potentiometer setting | | 1 |

Function: Set keyboard settings source

Principle explanation:
Select the source of keyboard setting value, digital setting (P02.92) or keyboard potentiometer. When the keyboard potentiometer setting is selected, P02.92 will keep the current potentiometer setting data, then select the keyboard numeric setting, and set the frequency to the previous potentiometer setting data.

| Parameter number | Function | Setting range | Unit | Factory Value |
|------------------|-----------------------------|---|------|---------------|
| P01.66 | keyboard M light source | 0: Always 0; 1: Always 1; 2: Stopped; 3: Running; 4: Fault; 5: Warning; 6: Reversing; 7: Ready; 64: STO state; 100 ~ 9999: Address | | 5 |
| P01.67 | Keyboard M light source bit | 0~31 | | 0 |

Function: Select the signal source of the keyboard M light

Principle explanation:
The set value of keyboard M light source is bigger or equal to 100 (address mode), the address is the selected parameter number, the actual value is determined by the current value of the selected parameter number. The bit position of the keyboard M light source is set bit selection. When the terminal source is address 100 ~ 9999, the bit setting is valid. The keyboard M light source setting value is less than 100 (non-address mode), and the keyboard M light source bit does not need to be set. The function description of the terminal source is as follows:

| Setting value | Function | Description |
|---------------|------------|---|
| 0 | Always 0 | Keyboard M light off |
| 1 | Always 1 | Keyboard M light on |
| 2 | Stopped | In the stopped state, the keyboard M light is on |
| 3 | Running | In the running state, the keyboard M light is on |
| 4 | Fault | In the fault state, the keyboard M light is on |
| 5 | Alarm | In the alarm state, the keyboard M light is on |
| 6 | Reversing | In the reversing state, the keyboard M light is on |
| 7 | Ready | In the ready state, the keyboard M light is on |
| 64 | STO status | In the STO state, the keyboard M light is on |
| 100~9999 | Address | Select the parameter as the output source of keyboard M light |

| Parameter number | Function | Setting range | Unit | Factory Value |
|------------------|------------------------|---------------|------|---------------|
| P01.68 | Display value 1 source | 0~9999 | | 1011 |
| P01.69 | Display value 2 source | 0~9999 | | 1091 |

Function: Set display value source

Principle explanation:
Set the source of the display value, the source is the parameter number, and the value of the corresponding parameter number is put into P10.98 and P10.99 to be used as the corresponding monitoring display of the keyboard. See the keyboard description for details.
The keyboard display value 1 and display value 2 can be flexibly selected, and the factory value displays the set value and set value 2. If want to select other status data display, set P01.68 and P01.69 to the corresponding parameter number, for example: the keyboard displays acceleration time 0 and acceleration time 1, you need to set the parameters P01.68 = 250, P01.69 = 251, at this time, the data of the keyboard display value 1 is the acceleration time 0, and the data of the display value 2 is the acceleration time 1.

6.2 Group 02 parameters: setting channel

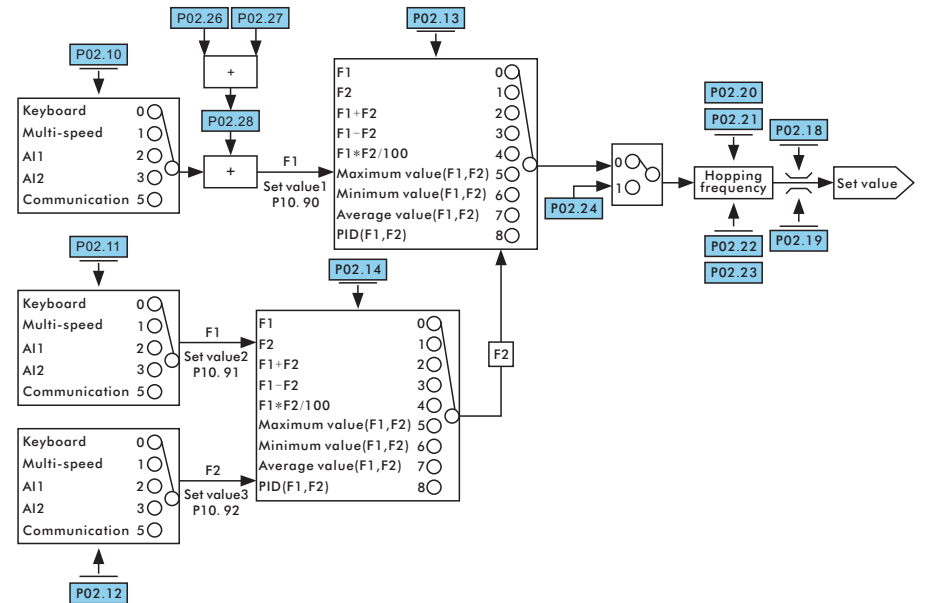
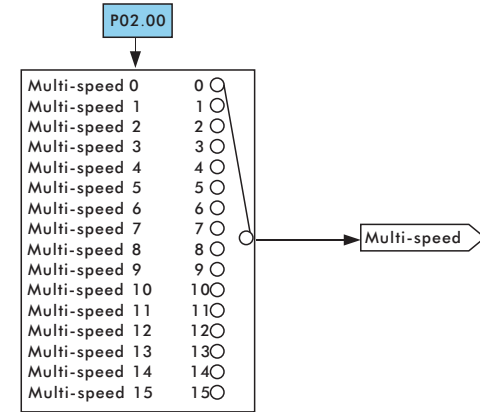

Figure 6-2-1 Set value source and channel setting

Function parameter description

Function parameter description

| Parameter number | Function | Setting range | Unit | Factory Value |
|------------------|------------------------------------|--|------|---------------|
| P02.00 | Multi-speed source | 0~11111111 | | 0 |
| P02.01 | Source of acceleration time | Units: S1; Tens: S2; | | 0 |
| P02.02 | Source of deceleration time | Hundreds: S3; ... | | 0 |
| P02.03 | Source of incremental command (UP) | Units: Keyboard; Tens: Communication; | | 0 |
| P02.04 | Source of decrement command (DOWN) | Hundreds: S1; Thousands: S2; ... | | 0 |

■ Function: Select command source

- P02.00: Multi-speed source, select the corresponding external terminal, see P02.30 ~ P02.45 for multispeed 0 ~ 15.
- P02.01: Source of acceleration time, select the corresponding external terminal. For acceleration time, please refer to P02.50 ~ P02.65.
- P02.02: source of deceleration time, select the corresponding external terminal, see P02.70 ~ P02.85 for deceleration time.
- P02.03: Source of incremental instruction (UP), select the corresponding source.
- P02.04: Decrease instruction (DOWN) source, select the corresponding source. See P02.26 ~ P02.28 for UP / DOWN parameters.
- Example: Select S2, S3, S4 as effective external terminals to control 8-stage speed:
Step 1: Select S2, S3, S4 as multi-speed terminals, P02.00 is set to 1110;
Step 2: Control S2, S3, S4 to switch multi-speed, the corresponding relationship between 8 multi-speed is as follows:

| S4 | S3 | S2 | Effective multi-speed |
|----|----|----|-----------------------|
| 0 | 0 | 0 | Multi-speed 0 |
| 0 | 0 | 1 | Multi-speed 1 |
| 0 | 1 | 0 | Multi-speed 2 |
| 0 | 1 | 1 | Multi-speed 3 |
| 1 | 0 | 0 | Multi-speed 4 |
| 1 | 0 | 1 | Multi-speed 5 |
| 1 | 1 | 0 | Multi-speed 6 |
| 1 | 1 | 1 | Multi-speed 7 |

| Parameter number | Function | Setting range | Unit | Factory Value |
|------------------|--------------------|---|------|---------------|
| P02.10 | Set value source 1 | 0: Keyboard; | | 0 |
| P02.11 | Set value source 2 | 1: Multi-speed; | | 0 |
| P02.12 | Set value source 3 | 2: AI1; 3: AI2; 5: Communication; 9: Pulse input; 200 ~ 9999: Address | | 0 |

■ Function: Select the source of the set value

- See P01.63 for keyboard setting value
- The communication setting value is written into P02.90 through communication.
- When the setting is 200 ~ 9999, this setting is the address. The address is the selected parameter number, and the actual value is determined by the current value of the selected parameter number.

| Parameter number | Function | Setting range | Unit | Factory Value |
|------------------|--------------------------------------|---|------|---------------|
| P02.13 | Set channel 1 relationship selection | 0:F1; 1:F2; 2:F1+F2; 3:F1-F2; 4:F1*F2/100; | | 0 |
| P02.14 | Set channel 2 relationship selection | 5:Maximum value(F1,F2); 6:Minimum value(F1,F2) ; 7:Average value(F1,F2) ; 8:PID(F1,F2) | | 0 |

■ Function: Select to set the channel relationship

➢ Principle explanation:

In the setting channel relationship, set 0 to select the F1 channel set value; Set 1 to select the F2 channel set value; Set 2 to select the sum of the F1 and F2 channel set values; Set 3 to select the difference between the F1 and F2 channel set values ; Set 4 to select the product of F1 and F2 channel set value divided by 100; Set 5 to select the maximum value in F1 and F2; Set 6 to select the minimum value in F1 and F2; Set 7 to select the average value of F1 and F2; Set 8 to select PID Control (F1 is set, F2 is feedback).

| Parameter number | Function | Setting range | Unit | Factory Value |
|------------------|-----------------------|-----------------|------|---------------|
| P02.18 | Maximum setting value | 0.000~99999.000 | | 50.000 |
| P02.19 | Minimum setting value | | | 0.000 |

■ Function: limit the set value range

➢ Principle explanation:

Limit the setting range to [P02.19, P02.18]. When each setting source is in units of %, the maximum setting value (P02.18) represents 100%, which is based on the maximum setting value. The output frequency is less than or equal to P05.08 motor frequency upper limit.

| Parameter number | Function | Setting range | Unit | Factory Value |
|------------------|-------------------------------|--------------------|------|---------------|
| P02.20 | Avoid-frequency 1 start point | -1000.000~1000.000 | % | 0.000 |
| P02.21 | Avoid-frequency 1 stop point | | | |
| P02.22 | Avoid-frequency 2 start point | | | |
| P02.23 | Avoid-frequency 2 stop point | | | |

■ Function: Set the avoidance frequency

➢ Principle explanation:

The set frequency of the inverter is given in a skipped manner in the avoidance frequency range in the manner of Figure 6-2-2.

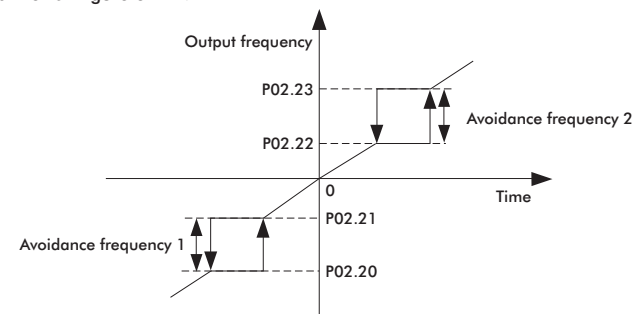

Figure 6-2-2 Avoidance frequency

Function parameter description

Function parameter description

| Parameter number | Function | Setting range | Unit | Factory Value |
|------------------|---------------|--------------------|------|---------------|
| P02.24 | Jog Frequency | -1000.000~1000.000 | % | 10.000 |

■ Function: Set the Jog frequency as a percentage of the maximum set value of P02.18. Jog command see P03.03

| Parameter number | Function | Setting range | Unit | Factory Value |
|------------------|--|---|------|---------------|
| P02.26 | Increase and decrease (UP / DOWN) Step-frequency | -100.0~100.0 | % | 0.2 |
| P02.27 | Increase and decrease (UP / DOWN) memory selection | 0: No memory; 1: Only power down memory; 2: Only stop memory; 3: Both power down and stop memory | | 3 |
| P02.28 | Speed up and down frequency | -1000.000~1000.000 | % | 0.000 |

■ Function: Select UP / DOWN function

➤ Principle explanation:

When the signal is activated, the frequency setting of the inverter increases or decreases by one unit. When the switch is held, the frequency will rapidly increase upward or downward to a certain time, and then increase or decrease uniformly. See P02.03 ~ P02.04 for the selection of UP / DOWN signal. P02.28 is only used for clearing UP / DOWN results. The data has no intuitive meaning after standardization.

| Parameter number | Function | Setting range | Unit | Factory Value |
|------------------|----------------|--------------------|------|---------------|
| P02.30 | Multi-speed 0 | -1000.000~1000.000 | % | 0.000 |
| P02.31 | Multi-speed 1 | | | |
| P02.32 | Multi-speed 2 | | | |
| P02.33 | Multi-speed 3 | | | |
| P02.34 | Multi-speed 4 | | | |
| P02.35 | Multi-speed 5 | | | |
| P02.36 | Multi-speed 6 | | | |
| P02.37 | Multi-speed 7 | | | |
| P02.38 | Multi-speed 8 | | | |
| P02.39 | Multi-speed 9 | | | |
| P02.40 | Multi-speed 10 | | | |
| P02.41 | Multi-speed 11 | | | |
| P02.42 | Multi-speed 12 | | | |
| P02.43 | Multi-speed 13 | | | |
| P02.44 | Multi-speed 14 | | | |
| P02.45 | Multi-speed 15 | | | |

■ Function: Multi-stage speed setting

| Parameter number | Function | Setting range | Unit | Factory Value |
|------------------|----------------------|----------------|------|---------------|
| P02.50 | Acceleration time 0 | 0.050~3600.000 | s | * |
| P02.51 | Acceleration time 1 | | | |
| P02.52 | Acceleration time 2 | | | |
| P02.53 | Acceleration time 3 | | | |
| P02.54 | Acceleration time 4 | | | |
| P02.55 | Acceleration time 5 | | | |
| P02.56 | Acceleration time 6 | | | |
| P02.57 | Acceleration time 7 | | | |
| P02.58 | Acceleration time 8 | | | |
| P02.59 | Acceleration time 9 | | | |
| P02.60 | Acceleration time 10 | | | |
| P02.61 | Acceleration time 11 | | | |
| P02.62 | Acceleration time 12 | | | |
| P02.63 | Acceleration time 13 | | | |
| P02.64 | Acceleration time 14 | | | |
| P02.65 | Acceleration time 15 | | | |

■ Function: acceleration time setting

➤ Principle explanation:

As shown in Figure 6-2-3, the acceleration time refers to the time required to accelerate from 0Hz to P06.13 motor frequency.

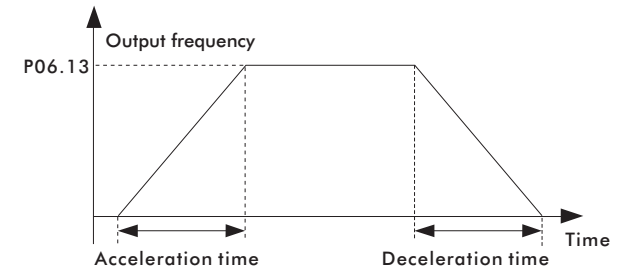

Figure 6-2-3 Acceleration and Deceleration

| Parameter number | Function | Setting range | Unit | Factory Value |
|------------------|-----------------------|----------------|------|---------------|
| P02.66 | JOG acceleration time | 0.050~3600.000 | s | 5.000 |

■ Function: Set Jog acceleration time

| Parameter number | Function | Setting range | Unit | Factory Value |
|------------------|-----------------------------|---------------|------|---------------|
| P02.68 | S curve acceleration time 1 | 0.000~100.000 | % | 0.000 |
| P02.69 | S curve acceleration time 2 | | | |

■ Function: Set S curve acceleration time

> Principle explanation:

S curve is used in places requiring gentle start or stop, such as elevators, conveyor belts, etc.

Note: When P02.68 and P02.89 are not 0, S curve acceleration and deceleration are effective.

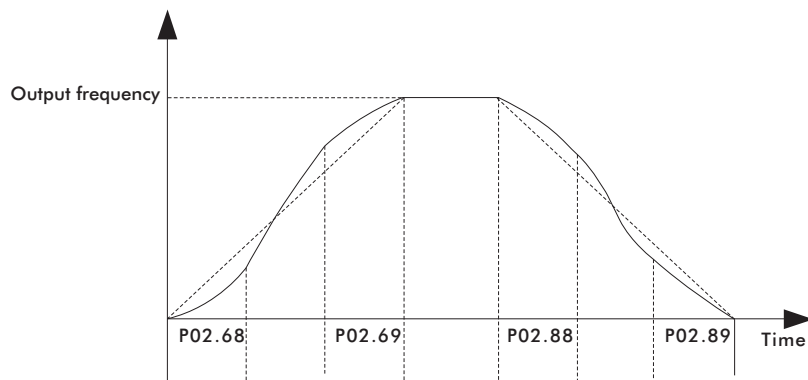

Figure 6-2-4 S curve acceleration and deceleration

| Parameter number | Function | Setting range | Unit | Factory Value |
|------------------|----------------------|----------------|------|---------------|
| P02.70 | Deceleration time 0 | 0.050~3600.000 | s | * |
| P02.71 | Deceleration time 1 | | | |
| P02.72 | Deceleration time 2 | | | |
| P02.73 | Deceleration time 3 | | | |
| P02.74 | Deceleration time 4 | | | |
| P02.75 | Deceleration time 5 | | | |
| P02.76 | Deceleration time 6 | | | |
| P02.77 | Deceleration time 7 | | | |
| P02.78 | Deceleration time 8 | | | |
| P02.79 | Deceleration time 9 | | | |
| P02.80 | Deceleration time 10 | | | |
| P02.81 | Deceleration time 11 | | | |
| P02.82 | Deceleration time 12 | | | |
| P02.83 | Deceleration time 13 | | | |
| P02.84 | Deceleration time 14 | | | |
| P02.85 | Deceleration time 15 | | | |

■ Function: Set deceleration time

> Principle explanation:

As shown in Figure 6-2-3, the deceleration time refers to the time required to decelerate from P06.13 motor frequency to 0Hz.

| Parameter number | Function | Setting range | Unit | Factory Value |
|------------------|------------------------|----------------|------|---------------|
| P02.86 | Jog Deceleration time | 0.050~3600.000 | s | 5.000 |
| P02.87 | Safe deceleration time | 0.050~3600.000 | s | 5.000 |

■ Function: Set Jog deceleration time and safe deceleration time (Jog command see P03.03, safe stop command see P03.06)

| Parameter number | Function | Setting range | Unit | Factory Value |
|------------------|-----------------------------|---------------|------|---------------|
| P02.88 | S curve deceleration time 1 | 0.000~100.000 | % | 0.000 |
| P02.89 | S curve deceleration time 2 | | | |

■ Function: Set S curve deceleration time (see P02.68, P02.69)

| Parameter number | Function | Setting range | Unit | Factory Value |
|------------------|-------------------------|--------------------|------|---------------|
| P02.90 | Communication set value | -1000.000~1000.000 | % | 0.000 |
| P02.91 | Communication command | 0~4294967295 | | 0 |
| P02.92 | Keyboard set value | -1000.000~1000.000 | % | 100.000 |
| P02.93 | Keyboard command | 0~4294967295 | | 0 |

■ Function: port between control command and set value, no need to set under normal circumstances, can be used for viewing

Table 6-2-2 Command control word table

| Command word (bit) | Definition |
|--------------------|-------------------------|
| 0 | Start |
| 1 | Reverse |
| 2 | Start reverse |
| 3 | JOG |
| 4 | Stop |
| 5 | Emergency stop |
| 6 | Safe stop |
| 7 | Reset |
| 9 | Parameter self-learning |
| 10 | Tripping |
| 11 | Pause |
| 13 | UP (incremental) |
| 14 | DOWN (decreasing) |

6.3 Group 03 parameters: input and output

| Parameter number | Function | Setting range | Unit | Factory Value |
|------------------|------------------------------|---|------|---------------|
| P03.00 | Start command source | 0 ~ 4294967295 | | 1 |
| P03.01 | Reverse start command source | Single command source mode (P01.39 = 0): 0: No effect; 1: Keyboard; | | 0 |
| P03.02 | Reverse command source | 2: communication; 3: S1; 4: S2 | | 0 |
| P03.03 | JOG command source | ... | | 1 |
| P03.04 | Stop command source | ... | | 0 |
| P03.05 | Free parking command source | 17 ~ 32: The 0 ~ 15 bits of P01.30 | | 0 |
| P03.06 | Safe stop command source | Multi-command source mode (P01.39 = 1): bit0: Keyboard; | | 0 |
| P03.07 | Reset command source | bit1: Communication; | | 1 |
| P03.08 | Fault command source | bit2: S1; bit3: S2; | | 0 |
| P03.09 | Pause command source | ... bit16~bit31:The 0~15 bit of P01.30 | | 0 |

Function: Select the command source (when the corresponding command source is selected as the keyboard, the reverse command, Jog command, and free stop command are all derived from the custom key M)

- Reverse start command: set value is reversed, and send out start command.
 - Reverse command: set value is reversed.
 - Jog command: Jog function. The priority is greater than the start command and lower than the stop command.
 - Safe stop: stop according to the safe deceleration time (P02.87). The priority is higher than the stop command and lower than the free stop command.
 - Fault command: send out a fault signal and the inverter will stop freely.
 - Pause command: The inverter stops freely, but the operating bit in the status word remains.
- Principle explanation:
P01.39 = 0 is single command source mode, P03.00 ~ P03.09 commands select a single source, index number 0: no effect; 1: keyboard; 2: communication,.... For example, when P03.00 = 3, he start command comes from S1. The operation of the host computer needs to select communication, and the single command function is effective.

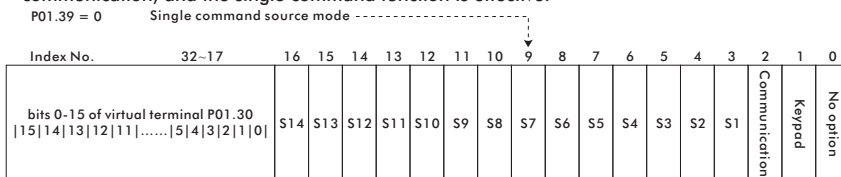

Figure 6-3-1 Single command source mode

P01.39 = 1 is multi-command source mode, P03.00 ~ P03.09 commands can select multiple sources, set bit selection bit0: keyboard, bit1: communication, For example, when P03.00 = 7 (binary 111), there are three ways to start the command source, which are keyboard, communication, and S1. The operation of the host computer needs to select communication, and the multi-command function is effective.

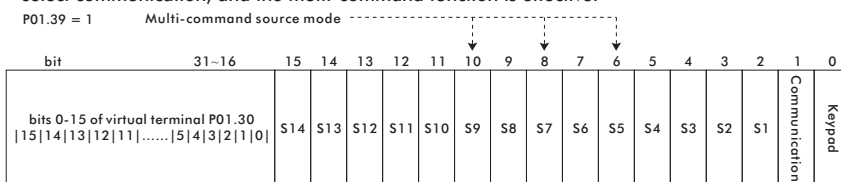

Figure 6-3-2 Multi-command source mode

| Parameter number | Function | Setting range | Unit | Factory Value |
|------------------|----------|--|------|---------------|
| P03.20 | S1 type | One place: 0: Positive logic 1: Reverse logic 2: Rising edge 3: Falling edge Tens place: 1: Rising edge toggle 2: Falling edge toggle Hundreds place: 1: The edge signal is not cleared by other edge signals Thousands place: 1: The edge signal is not cleared by the stop signal | | 0 |
| P03.21 | S2 type | | | |
| P03.22 | S3 type | | | |
| P03.23 | S4 type | | | |
| P03.24 | S5 type | | | |
| P03.25 | S6 type | | | |
| P03.26 | S7 type | | | |
| P03.27 | S8 type | | | |

Function: Set S curve acceleration time

Principle explanation:

- One place: 0: positive logic, High level is valid state, low level is invalid state;
1: Reverse logic, High level is invalid state, low level is valid state;
2: Rising edge, the rising edge is valid;
3: Falling edge, falling edge is valid.

- Tens place: 1: Rising edge ping-pong key;
2: Toggle on the falling edge.

The tens position can control the edge signal and realize a reset button to control start and stop.
Hundreds place: 1: The edge signal is not cleared by other edge signals;
Thousands place: 1: The edge signal is not cleared by the stop signal.

Two-wire mode 1:

This mode is the most commonly used two-wire mode with enable and direction in one. The switch signals K1 and K2 determine the forward and reverse rotation of the motor.

Table 6-3-1

| Parameter number | Set value | Note |
|------------------|-----------|---|
| P03.00 | 3 | The source of the start command is S1 |
| P03.01 | 4 | The source of the reverse start command is S2 |
| P03.20 | 0 | S1 type is positive logic |
| P03.21 | 0 | S2 type is positive logic |

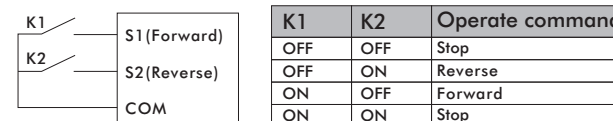

Chart 6-3-3

Two-wire mode 2:

The enable is separated from the direction. In this mode, K1 is the running enable terminal, and the direction is determined by K2.

Table 6-3-2

| Parameter number | Set value | Note |
|------------------|-----------|---|
| P03.00 | 3 | The source of the start command is S1 |
| P03.02 | 4 | The source of the reverse command is S2 |
| P03.20 | 0 | S1 type is positive logic |
| P03.21 | 0 | S2 type is positive logic |

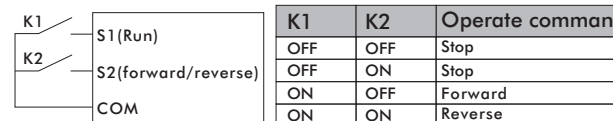

Chart 6-3-4

➤ Three-wire control mode 1:

This mode defines SB2 as an enable terminal, the running command is generated by SB1 or SB3, and controls the running direction at the same time. Inverter operation SB2 is in a closed state, and terminal SB1 or SB2 generates a rising edge signal to control the inverter operation and direction; when the inverter stops, it is necessary to disconnect terminal SB2 to complete the shutdown.

Table 6-3-3

| Parameter number | Set value | Note |
|------------------|-----------|---|
| P03.00 | 3 | The source of the start command is S1 |
| P03.01 | 5 | The source of the reverse start command is S3 |
| P03.04 | 4 | The source of the stop command is S2 |
| P03.20 | 2 | S1 type is rising edge |
| P03.21 | 1 | S2 type is reverse logic |
| P03.22 | 2 | S3 type is rising edge |

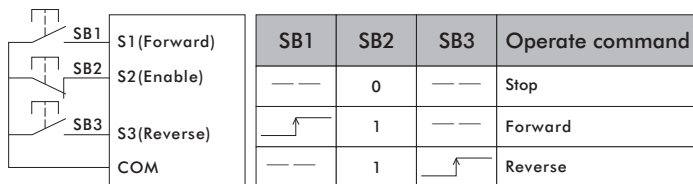

Chart 6-3-5

➤ Three-wire control mode 2:

This mode defines SB2 as an enable terminal, the run command is generated by button SB1, and the direction command is controlled by switch K. When the inverter is running, terminal SB2 needs to be in the closed state. Terminal SB1 generates a rising edge signal. The inverter starts to run. The state of switch K determines the running direction. When the inverter stops, terminal SB2 needs to be disconnected to complete the shutdown.

Table 6-3-4

| Parameter number | Set value | Note |
|------------------|-----------|--|
| P03.00 | 3 | The source of the start command is S1 |
| P03.02 | 5 | The source of the reverse command is S3 |
| P03.04 | 4 | The source of the stop command is S2 |
| P03.20 | 2 | S1 terminal command type is rising edge |
| P03.21 | 1 | S2 terminal command type is reverse logic |
| P03.22 | 0 | S3 terminal command type is positive logic |

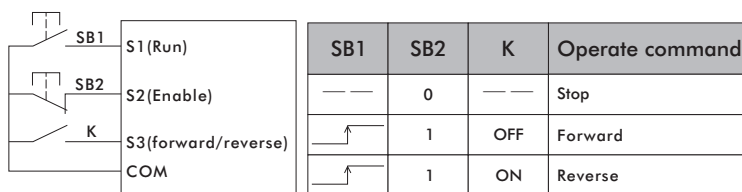

Chart 6-3-6

| Parameter number | Function | Setting range | Unit | Factory Value |
|------------------|--------------------------|--|------|---------------|
| P03.28 | S Input filtering | 1~16 | | 4 |
| P03.29 | Start signal enable mode | 0: Always enabled; 1: Need to re-enable after power on; 2: Need to re-enable after free stop or safe stop; 3: Need to re-enable after power-on, free stop or safe stop. | | 0 |

■ Function: Control S terminal input effect and enable mode

➤ S input filtering: S input signal is filtered, the larger the parameter value setting, the more obvious the filtering effect.

➤ Start signal enable mode: When the start command comes from the external terminal, the safety of the inverter is improved.

Set parameter P03.29 to 0. During power-up, the inverter detects that the start command terminal is valid, and the inverter starts immediately.

Set parameter P03.29 to 1. During power-up, even if the inverter detects that the start command terminal is valid, the inverter will not start. Only when the terminal is re-enabled, the inverter can start.

Set parameter P03.29 to 2. After free stop or safe stop, even if the inverter detects that the start command terminal is valid, the inverter will not start. Only the terminal is enabled again, the inverter can start.

Set parameter P03.29 to 3, the terminal needs to be re-enabled after power-on, free stop or safe stop before the inverter can start.

| Parameter number | Function | Setting range | Unit | Factory Value |
|------------------|--|--|------|---------------|
| P03.30 | Y1 terminal source (RA、RB、RC or RA1、RB1、RC1) | 0: Always 0; 1: Always 1; 2: Stopped; 3: Running; 4: Fault; 5: Warning; 6: Reversing; 7: Ready; 64: STO state; 100 ~ 9999: Address | | 3 |
| P03.31 | Y1 terminal source bit | 0~31 | | 0 |
| P03.32 | Y2 terminal source (RA2、RB2、RC2) | 0: Always 0; 1: Always 1; 2: Stopped; 3: Running; 4: Fault; 5: Warning; 6: Reversing; 7: Ready; 64: STO state; 100 ~ 9999: Address | | 4 |
| P03.33 | Y2 terminal source bit | 0~31 | | 0 |
| P03.34 | Y3 terminal source (RA3、RB3、RC3) | 0: Always 0; 1: Always 1; 2: Stopped; 3: Running; 4: Fault; 5: Warning; 6: Reversing; 7: Ready; 64: STO state; 100 ~ 9999: Address | | 5 |
| P03.35 | Y3 terminal source bit | 0~31 | | 0 |

■ Function: Select the signal source of the digital output terminal

➤ Principle explanation:

The terminal source setting value is greater than or equal to 100 (address mode), the address is the selected parameter number, and the actual value is determined by the current value of the selected parameter number. bit source of terminal source is set bit selection. When terminal source is address 100 ~ 9999, the bit setting is valid. The terminal source setting value is less than 100 (non-address mode), and the terminal source bit need not be set. The function description of the terminal source is as follows:

Function parameter description

Function parameter description

Table 6-3-5

| Set value | Function | Description |
|-----------|-----------|--|
| 0 | Always 0 | Y terminal output is always 0 |
| 1 | Always 1 | Y terminal output is always 1 |
| 2 | Stopped | In the stopped state, Y terminal output is 1 |
| 3 | Running | In the running state, Y terminal output is 1 |
| 4 | Fault | In the fault state, Y terminal output is 1 |
| 5 | Alarm | In the alarm state, Y terminal output is 1 |
| 6 | Reversing | In reverse state, Y terminal output is 1 |
| 7 | Ready | In the ready state, Y terminal output is 1 |
| 64 | STO state | In STO state, Y terminal output is 1 |
| 100~9999 | Address | Select parameters as Y output source |

| Parameter number | Function | Setting range | Unit | Factory Value |
|------------------|----------------------|----------------|------|---------------|
| P03.36 | Y1 output delay time | 0.000~6000.000 | s | 0.000 |
| P03.37 | Y2 output delay time | | | |
| P03.38 | Y3 output delay time | | | |

Function: Set Y1, Y2, Y3 output delay time

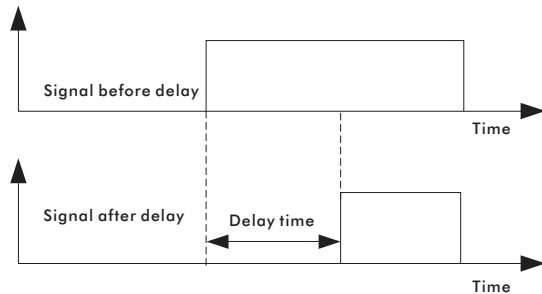

Figure: Set Y1, Y2, Y3 output delay time

| Parameter operation | Function | Setting range | Unit | Factory Value |
|---------------------|----------------|---------------|------|---------------|
| P03.39 | AI filter time | 0.100~600.000 | s | 0.100 |

Function: Set AI filter time

Principle explanation:

Adjust the sensitivity of the analog input, and increase the value appropriately to enhance the anti-interference of the analog, but it will reduce the sensitivity of the analog input.

| Parameter number | Function | Setting range | Unit | Factory Value |
|------------------|--------------------------------|------------------------------------|-------|---------------|
| P03.40 | AI1 signal type | 0: Voltage input; 1: Current input | | 0 |
| P03.41 | AI1 low-end voltage (current) | -999999.000~999999.000 | V(mA) | 0.000 |
| P03.42 | AI1 high-end voltage (current) | | | 10.000 |
| P03.43 | AI1 low-end setting | -999999.000~999999.000 | % | 0.000 |
| P03.44 | AI1 high-end setting | | | 100.000 |

Function: Analog input AI1 setting

- > AI1 signal type: select input signal type, set value is 0, voltage signal input; set value is 1, current signal input.
- > AI1 low-end voltage (current): set the minimum voltage (current) of the input signal.
- > AI1 high-end voltage (current): set the maximum voltage (current) of the input signal.
- > AI1 low-end setting: set the corresponding value of low-end voltage (current).
- > AI1 high-end setting: set the corresponding value of high-end voltage (current).

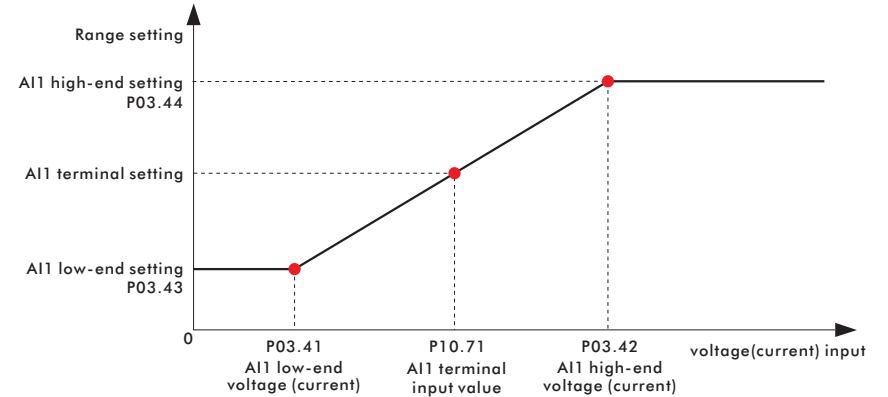

Figure 6-3-8 AI setting

| Parameter number | Function | Setting range | Unit | Factory Value |
|------------------|--------------------------------|------------------------------------|-------|---------------|
| P03.45 | AI2 signal type | 0: Voltage input; 1: Current input | | 0 |
| P03.46 | AI2 low-end voltage (current) | -999999.000~999999.000 | V(mA) | 0.000 |
| P03.47 | AI2 high-end voltage (current) | | | 10.000 |
| P03.48 | AI2 low-end setting | -999999.000~999999.000 | % | 0.000 |
| P03.49 | AI2 high-end setting | | | 100.000 |

Function: Analog input AI2 setting

> For details, please refer to P03.40 ~ P03.44.

Function parameter description

Function parameter description

| Parameter number | Function | Setting range | Unit | Factory Value |
|------------------|--------------------------------|---|--------|---------------|
| P03.60 | AO1 signal type | 0: Voltage output; 1: Current output | | 0 |
| P03.61 | AO1 signal source | 0: Always 0; 1: Always 10V / 20mA; 2: Output frequency; 3: Motor current; 4: Output voltage; 5: Motor torque; 6: Output power; 7: Set frequency 100~ 9999: Refer to the value of parameter number | | 2 |
| P03.62 | AO1 low-end setting | -999999.000~999999.000 | | 0.000 |
| P03.63 | AO1 high-end setting | | 50.000 | |
| P03.64 | AO1 low-end voltage (current) | -999999.000~999999.000 | V(mA) | 0.000 |
| P03.65 | AO1 high-end voltage (current) | | | 10.000 |

Function: Analog output AO1 setting

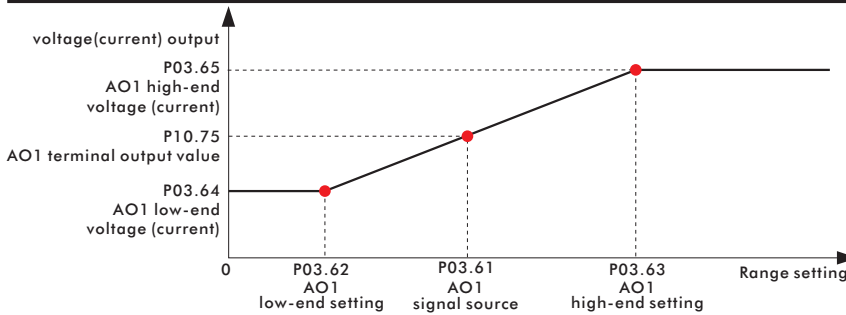

Figure 6-3-9 AO setting

- > AO1 signal type: select the output signal type, set value is 0, voltage signal output; set value is 1, current signal output.
- > AO1 signal source: select the signal source of AO1 output, 0: always 0; 1: always 10V / 20mA; 2: output frequency; ...
- > AO1 low-end setting: set the minimum value of AO1 source.
- > AO1 high-end setting: set the maximum value of AO1 source.
- > AO1 low-end voltage (current): set the minimum voltage (current) of the output signal.
- > AO1 high-end voltage (current): set the maximum voltage (current) of the output signal.
- > Principle explanation:

As shown in Fig. 6-3-9, set the AO1 signal source, check the P10.75 (AO1 terminal output value) of the AO1 terminal output value, or measure with a multimeter. The function description of AO1 signal source is as follows:

Table 6-3-6

| Set value | Function | Description |
|-----------|-------------------|---|
| 0 | Always 0 | Analog AO1 output has been 0 |
| 1 | Always 10V / 20mA | Analog AO1 output has been 10V / 20mA |
| 2 | Output frequency | Analog AO1 output is output frequency |
| 3 | Motor current | Analog AO1 output is motor current |
| 4 | Output voltage | Analog AO1 output is output voltage |
| 5 | Motor torque | Analog AO1 output is motor torque |
| 6 | Output power | Analog AO1 output is output power |
| 7 | Set frequency | Analog AO1 output is set frequency |
| 100~9999 | Parameter number | Select parameter as the source of analog AO1 signal |

| Parameter number | Function | Setting range | Unit | Factory Value |
|------------------|--------------------------------|--|--------|---------------|
| P03.66 | AO2 signal type | 0: Voltage output; 1: Current output | | 0 |
| P03.67 | AO2 signal source | 0: Always 0; 1: Always 10V / 20mA; 2: Output frequency; 3: Motor current; 4: Output voltage; 5: Motor torque; 6: Output power; 7: Set frequency 100~ 9999: The value of the reference parameter number | | 3 |
| P03.68 | AO2 low-end setting | -999999.000~999999.000 | | 0.000 |
| P03.69 | AO2 high-end setting | | 50.000 | |
| P03.70 | AO2 low-end voltage (current) | -999999.000~999999.000 | V(mA) | 0.000 |
| P03.71 | AO2 high-end voltage (current) | | | 10.000 |

Function: Analog output AO2 setting

> For details, please refer to P03.60 ~ P03.65.

6.4 Group 04 parameters: PID control

| Parameter number | Function | Setting range | Unit | Factory Value |
|------------------|----------------------------------|--------------------|------|---------------|
| P04.00 | PID proportional gain | 0.000~10.000 | % | 0.010 |
| P04.01 | PID integration time | 0.001~9999.000 | s | 10.000 |
| P04.02 | PID differential gain | 0.000~9999.000 | % | 0.000 |
| P04.03 | PID forward feedback coefficient | 0~500 | % | 0 |
| P04.04 | PID sampling time | 0.001~9999.000 | s | 0.004 |
| P04.05 | PID output upper limit | -1000.000~1000.000 | % | 100.000 |
| P04.06 | PID output lower limit | | % | 0.000 |
| P04.07 | PID output filter time | 0.000~600.000 | s | 0.000 |
| P04.09 | PID range | 0.001~99999.000 | | 100.000 |

Function: Simple PID control, enable PID control when P02.13 or P02.14 is set to 8

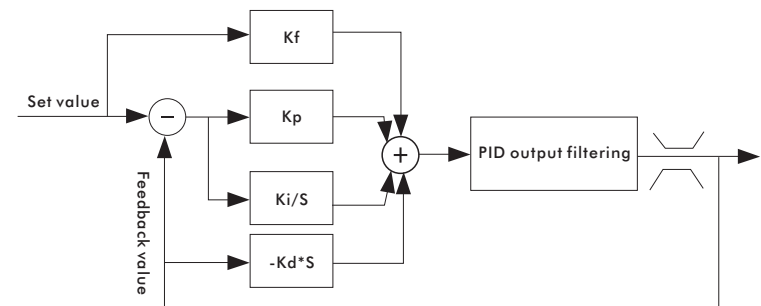

Figure 6-4-1 PID closed loop control

- > PID proportional gain: Determine the adjustment intensity of the entire PID regulator. The greater the proportional gain, the greater the adjustment intensity.
- > PID integration time: determine the speed of PID regulator to adjust the deviation of PID feedback and given amount. The smaller the integration time, the greater the adjustment intensity.
- > PID differential gain: determine the strength of PID regulator to adjust the deviation rate of PID feedback and given amount. The greater the differential gain, the greater the adjustment intensity.

Function parameter description

Function parameter description

- PID feedforward coefficient: generally use a smaller feedforward coefficient; otherwise, use a larger feedforward coefficient to make feedforward adjustment play a major role.
- PID sampling time: generally set 5~10 times smaller than the response time of the controlled object.
- PID output upper limit: the maximum value of PID adjustment output, higher than the maximum value, PID output upper limit.
- PID output lower limit: the minimum value of PID adjustment output, below the minimum value, PID output lower limit.
- PID output filtering time: The filtering time increases, weakens the output signal mutation, and reduces the closed-loop system response performance.
- PID range: according to the actual feedback range setting, if the setting is less than the feedback range PID does not work.
- Method of adjusting proportional gain and integration time:
First adjust the integration time to the minimum, set the differential gain to 0, observe the PID feedback value and adjust the PID proportional gain. Slowly increase the integration time, repeatedly adjust the two parameters of proportional gain and integration time according to the response of the PID feedback value, change the PID given value multiple times within the PID given range, and adjust the proportional gain and integration time until Achieve satisfactory performance within the entire working range. Differential gain can be adjusted according to the need of overshoot, in most cases the differential link is generally not used.

| Parameter number | Function | Setting range | Unit | Factory Value |
|------------------|------------------------|--|------|---------------|
| P04.11 | PID sleep frequency | 0.000~500.000 | % | 0.000 |
| P04.12 | PID enter sleep time | 0.000~3600.000 | s | 0.000 |
| P04.13 | PID wake-up deviation | 0.000~100.000 | % | 0.000 |
| P04.14 | PID enter wake-up time | 0.000~3600.000 | s | 0.000 |
| P04.15 | PID sleep action | 0: Do not sleep; 1: PID stop; 2: Decelerate to stop; 3: Free to stop; 4: Pause; 5: Lowest frequency operation | | 0 |

■ Function: PID control function selection

- Principle explanation:
As shown in Figure 6-4-2, the PID output value is less than the P04.11 sleep frequency. After the time set by the parameter P04.12 (PID enters sleep time), the PID enters sleep according to the sleep action; the PID wakeup value is greater than P04.13 wakeup Deviation (wake-up value = percentage of set value), after the time set by parameter P04.14 (PID enters wake-up time), PID restarts.
- PID sleep frequency: set the sleep quasi-frequency.
- PID wake up deviation: percentage based on setting. For example, when 10 kg is set and the wake-up deviation is 20%, the wake-up deviation is 2 kg (20% × 10). When the actual pressure is less than 8 kg, the wake-up state starts.
- PID enters sleep time: the inverter will enter sleep after reaching the sleep frequency and meeting the sleep time.
- PID enters the wake-up time: the inverter will restart after reaching the wake-up deviation and meeting the wake-up time.
- PID sleep action selection: PID enters sleep according to the set sleep action.
 - 0 Do not sleep: PID operation is not changed.
 - 1 PID stop: PID stops working.
 - 2 Deceleration stop: The inverter decelerates to stop.
 - 3 Free stop: The inverter freely stops.
 - 4 Pause: The inverter pauses.
 - 5 Lowest frequency operation: run at the lowest frequency, see parameter P04.06 (PID output lower limit frequency) for lowest frequency setting.

Note: When the PID sleep action selects deceleration stop or free stop, sleep will cause the start signal to be cleared once. Therefore: when the start signal comes from the keyboard, the start signal will be cleared after sleep. If the automatic wake-up function is required, select PID to stop or pause or the lowest frequency operation for PID sleep action. When the start signal comes from the S terminal input or communication (the communication continues to send the start signal), the PID sleep action will not affect the PID wakeup.

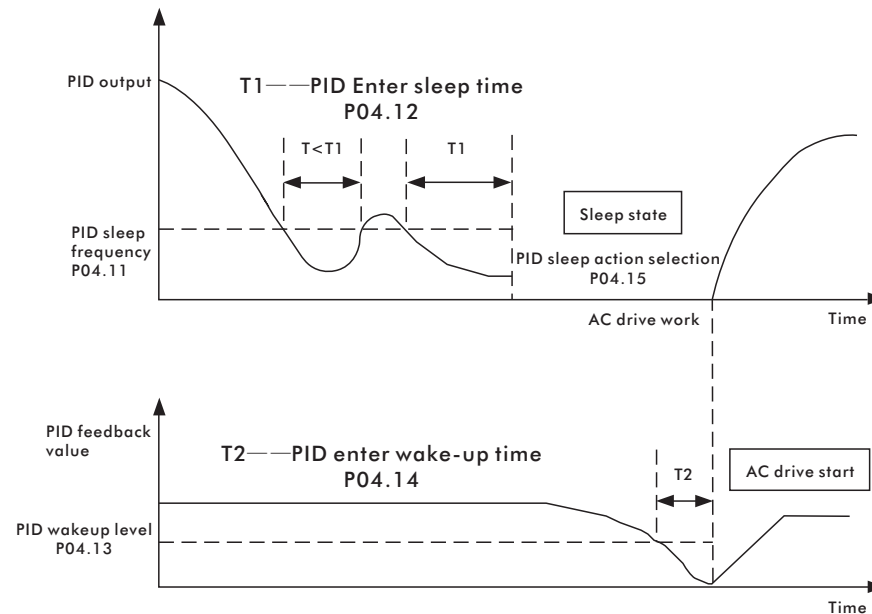

Figure 6-4-2 PID sleep wake up

| Parameter number | Function | Setting range | Unit | Factory Value |
|------------------|------------|---------------|------|---------------|
| P04.90 | PID status | 0~4294967295 | | |

■ Function: indicates the PID status word (see the table below for the definition of each bit).

Table 6-4-1

| Status word (bit) | Definition |
|-------------------|-------------------|
| 0 | PID is stopped |
| 1 | PID is running |
| 5 | PID goes to sleep |

6.5 Group 05 parameters: system control

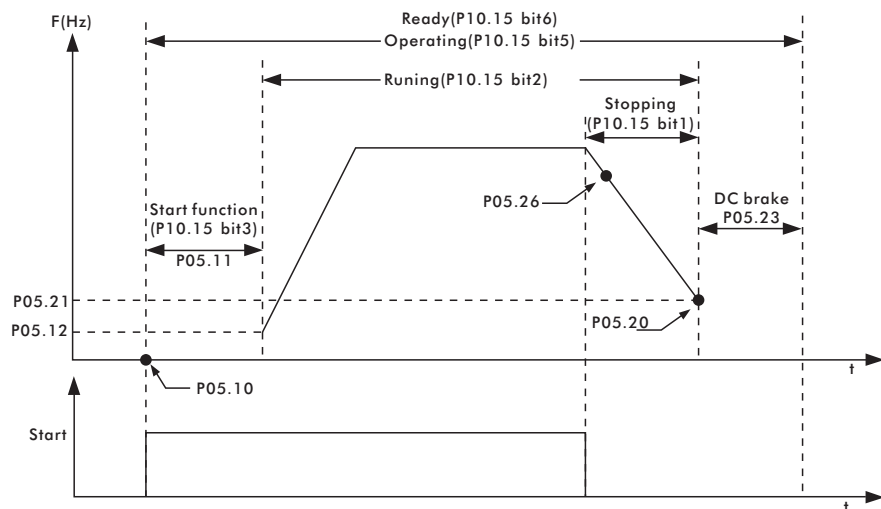

Figure 6-5-1 System control

| Parameter number | Function | Setting range | Unit | Factory Value |
|------------------|--------------|---------------------------------|------|---------------|
| P05.00 | Control mode | 0: VF; 1: Open loop vector 1 | | 1 |

■ Function: Select motor control algorithm

| Parameter number | Function | Setting range | Unit | Factory Value |
|------------------|------------------------------------|----------------|------|---------------|
| P05.06 | Forward and reverse switching time | 0.000~6000.000 | s | 0.000 |

■ Function: control forward and reverse switching dead zone time

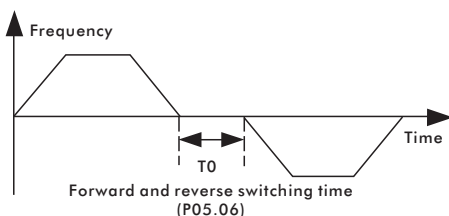

Figure 6-5-2 Switching between forward and reverse

| Parameter number | Function | Setting range | Unit | Factory Value |
|------------------|-------------------------|---|------|---------------|
| P05.07 | Forced change direction | 0: No effect; 1: Forced change direction | | 0 |

■ Function: control the commutation function, when the parameter P05.07 is set to 1, change the current running direction

| Parameter number | Function | Setting range | Unit | Factory Value |
|------------------|-----------------------------|--------------------|------|---------------|
| P05.08 | Motor frequency upper limit | -1020.000~1020.000 | Hz | 55.000 |

■ Function: Motor output frequency limit

> Motor frequency upper limit: define the motor operating frequency upper limit.

| Parameter operation | Function | Setting range | Unit | Factory Value |
|---------------------|-----------------|---|------|---------------|
| P05.10 | Start function | 0: When the time of P05.11 is over, run according to the frequency of P05.12; 1: On speed start; 2: DC injection 3: Run at the frequency of P05.12 within the time of P05.11 | | 0 |
| P05.11 | Start Time | 0.000~60000.000 | s | 0.000 |
| P05.12 | Start frequency | 0.000~100.000 | Hz | 0.000 |

■ Function: Set Startup function

> Principle explanation:

When the system starts up, it will work according to the setting start function within the setting start time. When start function is end, if the setting frequency is greater than the start frequency, the system starts to run with the start frequency as the start frequency; If the setting frequency is less than the start frequency, the system starts to run at the setting frequency.

> Start function:

- 0: The starting mode without output frequency can meet the starting time setting of P05.11, and the starting frequency of P05.12 starts to run.
- 1: Speed start, search for motor speed in rotation, start smooth starting without impact from the speed searched.
- 2: DC injection, inverter starts in the mode of "DC injection before starting".
- 3: After receiving the start command, the inverter runs at the starting frequency of P05.12 firstly, and then runs at the setting frequency after meeting the time of P05.11.

| Parameter number | Function | Setting range | Unit | Factory Value |
|------------------|---------------------|---|------|---------------|
| P05.14 | On speed start mode | 0: All directional; 1: Set value direction; 2 ~ 3: reserved | | 0 |

■ Function: Set the speed start function (set P05.10 to 1 speed start)

> Speed start mode:

- 0: Two-way, follow the forward or reverse direction for speed tracking judgment.
- 1: Set value direction, follow the set direction for speed tracking judgment.

| Parameter number | Function | Setting range | Unit | Factory Value |
|------------------|----------------------|---------------|------|---------------|
| P05.19 | DC injection current | 0.000~200.000 | % | 100.000 |

■ Function: Set the DC injection current size (set P05.10 to 2 DC injection)

> Principle explanation:

When the starting method is DC injection, the DC braking current needs to be set to 100% corresponding to the rated current of the inverter.

Function parameter description

Function parameter description

| Parameter number | Function | Setting range | Unit | Factory Value |
|------------------|----------------|---|------|---------------|
| P05.20 | Stop function | Units: 0: Free parking; 1: DC braking; Tens: 1: Precise parking | | 0 |
| P05.21 | Stop frequency | 0.000~1000.000 | Hz | 0.000 |

Function: Set stop function

> Principle explanation:

During the stop process, when the output frequency is less than the stop frequency, the stop function starts to work.

Precise parking: The motor rotates the same number of revolutions at any speed to achieve consistent repeatability of the parking position. To achieve the best results, the deceleration time should be as long as possible so as not to trigger the overvoltage and overcurrent stall prevention functions.

| Parameter number | Function | Setting range | Unit | Factory Value |
|------------------|----------------------------|----------------|------|---------------|
| P05.22 | DC braking | 0.000~300.000 | % | 100.000 |
| P05.23 | DC braking time | 0.000~1000.000 | s | 0.000 |
| P05.24 | Demagnetization time ratio | 0.000~1000.000 | % | 10.000 |

Function: Set the DC braking parameters of the stop function

> DC braking: set DC brake 0.000~200.000 as current brake and 200.001~300.000 as voltage brake.

> DC braking time: set the DC braking time. When set to 1000.000, always braking until receiving free stop or start signal.

> Demagnetization time ratio: Generally, no modification is required. For occasions requiring accurate positioning and strict deceleration time, reduce the demagnetization time ratio; where the requirements for deceleration time are not strict, appropriately increase the demagnetization time ratio to reduce the deceleration current impact.

| Parameter number | Function | Setting range | Unit | Factory Value |
|------------------|--|----------------|------|---------------|
| P05.26 | Magnetic flux brake activation frequency | 0.000~1000.000 | Hz | 0.000 |
| P05.27 | Magnetic Flux braking coefficient | 100~200 | % | 100 |
| P05.28 | Magnetic Flux braking time | 0.000~1000.000 | s | 0.000 |

Function: Set the flux braking parameters of the stop function

> Principle explanation:

During the stop, when the output frequency is less than the flux braking activation frequency, the flux braking function starts to take effect during the flux braking time. Flux braking is generally used in situations that require rapid deceleration, but excessive use will cause the motor to heat up.

| Parameter number | Function | Setting range | Unit | Factory Value |
|------------------|-----------------------|-----------------------------------|------|---------------|
| P05.30 | Brake resistance mode | 0: Invalid; 1: Maximum duty cycle | | 1 |

Function: Braking resistor braking mode parameter setting

| Parameter number | Function | Setting range | Unit | Factory Value |
|------------------|-----------------|---------------|------|---------------|
| P05.50 | Auto reset mode | 0~9999 | | 0 |
| P05.51 | Auto reset time | 0.000~600.000 | s | 10.000 |

Function: Set automatic reset function

> Principle explanation:

If the parameter P05.50 is not 0, the automatic reset function is valid, the number of automatic resets is the set value of P05.50, and the automatic reset time is the time when the fault is delayed. If P05.50 is set to 9999, it can be reset any number of times. If P05.50 is set greater than 0 and less than 9999, when the number of automatic resets exceeds P05.50, the inverter will report a fault.

| Parameter number | Function | Setting range | Unit | Factory Value |
|------------------|--|---------------|------|---------------|
| P05.60 | Auto energy saving minimum magnetic flux | 30~100 | % | 100 |
| P05.61 | Auto energy saving start frequency | 0.000~200.000 | Hz | 5.000 |

Function: Set automatic energy saving function

> Principle explanation:

Automatic energy saving automatically adjusts the output voltage according to the motor load to achieve the purpose of energy saving. When P06.70 is set to 1, P05.60 set value is less than 100 and the running frequency is greater than P05.61, the automatic energy saving function is effective.

| Parameter number | Function | Setting range | Unit | Factory Value |
|------------------|------------------------------------|---------------|------|---------------|
| P05.63 | Manual energy saving magnetic flux | 30~90 | % | 70 |

Function: Set manual energy-saving magnetic flux size

> Principle explanation:

When P06.70 is set to 1 and the automatic energy saving function is invalid, manual energy saving is effective. If P05.63 is set to 100, manual energy saving is invalid. Adjust the energy saving effect by setting the parameter P05.63 magnetic flux size. The smaller the set value, the more obvious the energy saving effect, but the torque response speed becomes slower.

| Parameter number | Function | Setting range | Unit | Factory Value |
|------------------|---------------------|---------------|------|---------------|
| P05.71 | Current upper limit | 0~300 | % | 150 |

Function: When the running current is greater than the upper current limit, the overcurrent stall function is activated. The current reference is the motor rated current (P06.14).

| Parameter number | Function | Setting range | Unit | Factory Value |
|------------------|------------------------------------|---------------|------|---------------|
| P05.76 | Upper limit of electric torque | 0.000~900.000 | % | 150.000 |
| P05.77 | Upper limit of regenerative torque | 0.000~900.000 | % | 150.000 |

Function: Set torque limit function

> Principle explanation:

Parameters P05.76 and P05.77 set the upper limit of electric and regenerative torque.

| Parameter number | Function | Setting range | Unit | Factory Value |
|------------------|---|--------------------------------------|------|---------------|
| P05.80 | Over-voltage control | 0: Invalid; 1: Valid at all times | | 1 |
| P05.82 | Over-voltage control scale coefficient | 0~200 | % | 100 |
| P05.83 | Over-voltage control integral coefficient | 1~10000 | % | 100 |

■ Function: Set overvoltage control function

➤ Principle explanation:

When the regenerative voltage exceeds the set threshold, the overvoltage control starts to activate the overvoltage stall function according to the setting of parameter P05.80.

| Parameter number | Function | Setting range | Unit | Factory Value |
|------------------|--------------------------|---|------|---------------|
| P05.85 | Under-voltage control | Units: grid power-down action mode 0: Invalid; 1: Instantaneous stop no stop; 2: Safe parking; 3 ~ 6: reserved Tens: under-voltage action mode of power grid 0: Invalid; 1: Safe frequency reduction | | 0 |
| P05.86 | Power grid voltage level | 100~800 | V | * |

■ Function: Set undervoltage control function

➤ Principle explanation:

When the input voltage is lower than the grid power-down level, the power-down action starts to activate according to the parameter P05.85 bit setting. Grid undervoltage means that the grid voltage is lower than the normal voltage, and the undervoltage action starts to activate according to the parameter P05.85 tens place setting.

| Parameter number | Function | Setting range | Unit | Factory Value |
|------------------|-----------------------------|---|------|---------------|
| P05.90 | AVR function selection | 0: invalid; 1: valid; 2: Only invalid when decelerating | | 1 |
| P05.91 | AVR function damping factor | 0~100 | % | 100 |

■ Function: Set AVR function

➤ Principle explanation:

AVR is used to compensate the fluctuation of grid voltage and keep the output voltage constant. When P05.90 is selected as 2, it is conducive to rapid deceleration.

6.6 Group 06 parameters: Motor model

| Parameter number | Function | Setting range | Unit | Factory Value |
|------------------|-------------------------------|--|------|---------------|
| P06.00 | Motor parameter self-learning | 0: Invalid 1: Complete self-learning 2: Simple self-learning | | 0 |

■ Function: Online learning of motor parameters

➤ Principle explanation:

During complete self-learning and simple self-learning, the motor will not rotate. After self-learning, the parameters such as motor stator impedance and rotor impedance will change. Before motor parameter self-learning, input motor nameplate parameters P06.10 ~ P06.15.

Self-learning process: Set P06.00, press the run key to start self-learning. When the self-learning is normal, the keyboard displays L0000. After the self-learning is completed, press the stop key to exit the self-learning and return to the normal state.

| Parameter number | Function | Setting range | Unit | Factory Value |
|------------------|-------------------|---------------|------|---------------|
| P06.05 | Carrier frequency | 2~16 | kHz | * |

■ Function: Set carrier frequency

| Parameter number | Function | Setting range | Unit | Factory Value |
|------------------|--------------------------|----------------------|------|---------------|
| P06.06 | Over-modulation function | 0: Invalid; 1: Valid | | 1 |

■ Function: Set over modulation function

| Parameter number | Function | Setting range | Unit | Factory Value |
|------------------|-----------------------|--|------|---------------|
| P06.10 | Motor type | 0: Asynchronous motor; 1: Surface mount permanent magnet synchronization; 2: Salient pole permanent magnet synchronization; 4: Single-phase motor | | 0 |
| P06.11 | Motor rated Power | 0.000~100000.000 | kW | * |
| P06.12 | Motor rated voltage | 0~1000 | V | * |
| P06.13 | Motor rated frequency | 1~3000 | Hz | * |
| P06.14 | Motor rated current | 0.00~1000.00 | A | * |
| P06.15 | Motor rated speed | 10~65535 | rpm | * |
| P06.16 | Motor power factor | 0.00~1.00 | | * |
| P06.17 | Number of motor poles | 2~100 | | * |
| P06.18 | Motor rated torque | 0.1~10000.0 | N·m | * |
| P06.19 | Motor no-load current | 0.00~1000.00 | A | * |

■ Function: Set motor parameters

| Parameter number | Function | Setting range | Unit | Factory Value |
|------------------|-----------------------|-----------------|--------|---------------|
| P06.20 | PM motor back EMF/rev | 1.000~10000.000 | mV/rpm | * |

■ Function: Set the back EMF corresponding to the rated speed of the permanent magnet synchronous motor

| Parameter number | Function | Setting range | Unit | Factory Value |
|------------------|--------------------------|---------------|----------|---------------|
| P06.40 | Stator impedance | 0.000~99.990 | Ω | * |
| P06.41 | Rotor impedance | 0.000~99.990 | Ω | * |
| P06.42 | Stator leakage reactance | 0.000~999.990 | mH | * |
| P06.44 | Motor main reactance | 0.00~999.90 | mH | * |

■ Function: Motor model parameters (obtained by self-learning of motor parameters)

| Parameter number | Function | Setting range | Unit | Factory Value |
|------------------|--|----------------|------|---------------|
| P06.50 | PM d-axis reactance | 0.000~1000.000 | mH | * |
| P06.51 | PM q-axis reactance | 0.001~9999.000 | mH | * |
| P06.52 | PM d-axis reactance saturation coefficient | 0.0~100.0 | % | * |
| P06.53 | PM q-axis reactance saturation coefficient | 0.0~100.0 | % | * |
| P06.54 | Maximum field weakening current d | 10~400 | % | 100 |
| P06.55 | Maximum field weakening current q | 10~400 | % | 100 |

■ Function: Permanent magnet synchronous motor model parameters (obtained by self-learning of motor parameters)

| Parameter number | Function | Setting range | Unit | Factory Value |
|------------------|--------------------------------|---------------|------|---------------|
| P06.60 | Single-phase motor turns ratio | 0.200~1.800 | | 1.000 |

■ Function: Set single-phase motor turn ratio

| Parameter number | Function | Setting range | Unit | Factory Value |
|------------------|-----------|---|------|---------------|
| P06.70 | Load type | 0: Constant torque; 1: Fan water pump; 2: Promotion; 3: Reserved | | 0 |

■ Function: Select the appropriate load type to obtain the corresponding torque characteristics, optimize the control algorithm

| Parameter number | Function | Setting range | Unit | Factory Value |
|------------------|-----------------------------------|---------------|------|---------------|
| P06.80 | Motor cable compensation strength | 0~500 | | 0 |

■ Function: This parameter needs to be set when the motor cable exceeds 100 meters, and 20 is recommended to set.

6.7 Group 07 parameters: control algorithm

| Parameter number | Function | Setting range | Unit | Factory Value |
|------------------|-----------------------------------|---------------|------|---------------|
| P07.50 | Slip compensation | -500~500 | % | 100 |
| P07.51 | Slip compensation filter constant | 1~10000 | % | 100 |

■ Function: Set vector control slip

➤ Slip compensation: adjust the speed stability accuracy of the motor. When the motor is under heavy load, the speed is low, increase this parameter, otherwise reduce this parameter. (For the need of soft load, provide negative value selection)

| Parameter number | Function | Setting range | Unit | Factory Value |
|------------------|--|---------------|------|---------------|
| P07.52 | Resonance suppression coefficient | 0~10000 | % | 100 |
| P07.53 | Low-speed suppression filter constant | 1~10000 | % | 100 |
| P07.54 | High-speed suppression filter constant | 1~10000 | % | 100 |

■ Function: Set resonance suppression coefficient, high and low speed suppression filter constant

➤ Principle explanation:

The no-load frequency conversion control system is prone to resonance, and the resonance suppression function helps eliminate vibration.

| Parameter number | Function | Setting range | Unit | Factory Value |
|------------------|------------------------------------|---------------|------|---------------|
| P07.55 | Automatic torque boost coefficient | 0~300 | % | 100 |

■ Function: Set automatic torque boost coefficient

➤ Principle explanation:

According to the load, the output voltage at low frequency is automatically compensated to improve the load capacity at low frequency.

| Parameter number | Function | Setting range | Unit | Factory Value |
|------------------|----------------------------------|---------------|------|---------------|
| P07.57 | Low speed minimum current | 0~300 | % | 50 |
| P07.58 | Static friction lift coefficient | 0~10000 | % | 100 |
| P07.59 | Static friction lift time | 0.0~1000.0 | S | 0.0 |

■ Function: Set low speed minimum current and static friction parameters

➤ Principle explanation:

Low speed minimum current given the minimum current at low speed, proper settings help to improve the low speed load capacity. The static friction lifting function automatically compensates the output voltage at the start according to the load, thereby increasing the starting torque.

| Parameter number | Function | Setting range | Unit | Factory Value |
|------------------|-------------|---------------|------|---------------|
| P07.71 | VF curve-F1 | 0.0~3000.0 | Hz | 50.0 |
| P07.72 | VF curve-F2 | | | 50.0 |
| P07.73 | VF curve-F3 | | | 50.0 |
| P07.74 | VF curve-F4 | | | 50.0 |
| P07.75 | VF curve-V0 | 0~10000 | V | 0 |
| P07.76 | VF curve-V1 | | | * |
| P07.77 | VF curve-V2 | | | * |
| P07.78 | VF curve-V3 | | | * |
| P07.79 | VF curve-V4 | | | * |

■ Function: Set VF curve

➤ Principle explanation:

Set the V / F curve in V / F control mode. When vector control 1 is used, the corresponding data points of the V / F curve can be set to adjust the control characteristics of the corresponding control points.

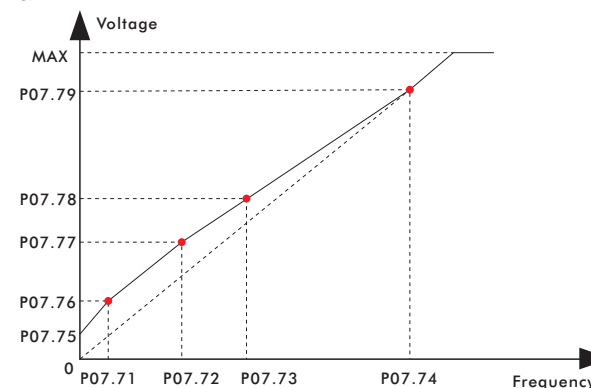

Figure 6-7-1 VF control curve

Function parameter description

Function parameter description

6.8 Group 09 parameters: system protection

| Parameter number | Function | Setting range | Unit | Factory Value |
|------------------|-------------------------|--------------------------------------|------|---------------|
| P09.00 | Input phase loss action | 0: Fault; 1: Alarm; 2: Invalid | | 2 |

■ Function: Set input phase loss action

| Parameter number | Function | Setting range | Unit | Factory Value |
|------------------|-----------------------------|-------------------------|------|---------------|
| P09.04 | Output phase loss detection | 0: Invalid; 1: Valid | | 1 |

■ Function: Set the action when output phase loss protection

| Parameter number | Function | Setting range | Unit | Factory Value |
|------------------|---------------|--------------------------------------|------|---------------|
| P09.06 | ETR selection | 0: Invalid; 1: Alarm; 2: Fault | | 2 |

■ Function: Select ETR action

| Parameter number | Function | Setting range | Unit | Factory Value |
|------------------|-----------------------|--|------|---------------|
| P09.49 | STO display selection | 0: STO/STO1/STO2/STO3 state is not displayed; 1: Display alarm in STO state; 2: Display fault in STO state | | 0 |

■ Function: STO display selection

6.9 Group 10 parameters: system status

| Parameter number | Function | Setting range | Unit | Factory Value |
|------------------|-------------------------|---------------|------|---------------|
| P10.05 | Software version number | | | |

■ Function: Indicate the inverter software version number.

| Parameter number | Function | Setting range | Unit | Factory Value |
|------------------|--------------|---------------|------|---------------|
| P10.10 | Control word | 0~4294967295 | | |

■ Function: Indicates the system control word.
The definition of each bit is shown in the table below:

Table 6-9-1

| Control word(bit) | Definition |
|-------------------|-------------------------|
| 0 | Start |
| 1 | Reverse |
| 2 | Start reverse |
| 3 | JOG |
| 4 | Stop |
| 5 | Emergency stop |
| 6 | Safe stop |
| 7 | Reset |
| 9 | Parameter self-learning |
| 10 | Tripping |
| 11 | Pause |
| 13 | UP (incremental) |
| 14 | DOWN (decreasing) |

| Parameter number | Function | Setting range | Unit | Factory Value |
|------------------|-----------|------------------|------|---------------|
| P10.11 | Set value | -65535.0~65535.0 | | |

■ Function: Indicate the set frequency value, see Figure 6-2-1

| Parameter number | Function | Setting range | Unit | Factory Value |
|------------------|---------------|---------------|------|---------------|
| P10.15 | Current state | 0~4294967295 | | |

■ Function: Indicates the system status word (see the table below for the definition of each bit). The specific meaning is shown in Figure 6-5-1.

Table 6-9-2

| Status word(bit) | Definition |
|------------------|--------------------------------|
| 0 | The power is being cut off |
| 1 | Stopping |
| 2 | Running |
| 3 | Start function starts |
| 4 | Parameter self-learning starts |
| 5 | Operating |
| 6 | Ready |
| 10 | Fault |
| 11 | Alarm |
| 12 | STO status |

| Parameter number | Function | Setting range | Unit | Factory Value |
|------------------|--------------------|---------------|------|---------------|
| P10.16 | Fault state word 1 | 0~4294967295 | | |
| P10.17 | Fault state word 2 | 0~4294967295 | | |

■ Function: Indicate the system fault status word (see the table below for the definition of each bit)

Table 6-9-3

| Fault status word 1 (bit) | Definition |
|---------------------------|---------------------------------------|
| 1 | System abnormality |
| 4 | Ground fault |
| 5 | Short circuit to ground |
| 6 | Output short circuit |
| 7 | Output overcurrent |
| 8 | DC bus overvoltage |
| 9 | DC bus undervoltage |
| 10 | Inverter overheating |
| 11 | Self-learning failure |
| 13 | Rectifier bridge overheating |
| 14 | U phase missing phase |
| 15 | V phase missing phase |
| 16 | W phase missing phase |
| 19 | No motor connection |
| 20 | Input phase loss |
| 21 | Inverter overload |
| 22 | Overtorque |
| 24 | Motor overheating |
| 25 | Motor overload |
| 26 | Current limit |
| 27 | Input power down |
| Fault status word 2 (bit) | Definition |
| 31 | External fault |
| 33 | STO safe torque stop |
| 34 | STI1 internal circuit abnormal |
| 35 | STI2 internal circuit abnormal |
| 36 | STI1 and S TI2 internal loop abnormal |

Function parameter description

Function parameter description

| Parameter number | Function | Setting range | Unit | Factory Value |
|------------------|------------------|---------------|------|---------------|
| P10.18 | Alarm state word | 0~4294967295 | | |

■ Function: indicate the system alarm status word (see the description of the above table for the definition of each bit)

| Parameter number | Function | Setting range | Unit | Factory Value |
|------------------|---------------------------------|------------------|------|---------------|
| P10.20 | Output frequency absolute value | 0.0~65535.0 | Hz | |
| P10.21 | Output frequency | -65535.0~65535.0 | Hz | |
| P10.22 | Output current | 0.00~65535.00 | A | |
| P10.23 | Output voltage | 0.0~65535.0 | V | |
| P10.24 | Output torque | 0.000~65535.000 | N·m | |

■ Function: Indicate output information

| Parameter number | Function | Setting range | Unit | Factory Value |
|------------------|----------------------|-------------------|------|---------------|
| P10.25 | DC voltage | 0.0~65535.0 | V | |
| P10.26 | Inverter temperature | 0~65535 | °C | |
| P10.27 | Inverter hot load | 0~65535 | % | |
| P10.28 | Motor hot load | 0~65535 | % | |
| P10.30 | power | 0.000~65535.000 | kW | |
| P10.31 | Energy consumption | 0.000~4294967.295 | kW·h | |

■ Function: Indicate the running status information of the inverter

| Parameter number | Function | Setting range | Unit | Factory Value |
|------------------|--------------------|-------------------|------|---------------|
| P10.40 | Hours of power on | 0.000~4294967.295 | h | |
| P10.41 | Number of power-on | 0~4294967295 | | |

■ Function: Instruct inverter statistics

| Parameter number | Function | Setting range | Unit | Factory Value |
|------------------|-----------------------|----------------|------|---------------|
| P10.44 | Communication timeout | 0.000~9999.000 | s | |

■ Function: Monitor the communication timeout of inverter and upper computer

► Principle explanation:

After the inverter is powered on, if there is no communication with the upper computer, the communication timeout is 0.

After only one normal communication, when the communication is normal, the timeout is less than 0.1 data change. At this time, if the communication is abnormal, the communication timeout will be accumulated and counted. The user can use the comparator to judge the communication failure shutdown. Check the parameters as below:

| Parameter number | Function | Setting Value |
|------------------|---|---------------|
| P01.30 | Virtual terminal setting | 1340 |
| P03.08 | Fault command source | 17 |
| P12.00 | Free parameter 1 | 3.000 |
| P16.00 | Comparator 1 input parameter selection | 1044 |
| P16.01 | Comparator 1 comparison parameter selection | 1200 |
| P16.02 | Comparator 1 configuration | 2 |

Function description: When communication timeout $\geq 3s$, the inverter will stop in case of fault, and the keyboard will display E0063.

| Parameter number | Function | Setting range | Unit | Factory Value |
|------------------|-----------------------------|---------------|------|---------------|
| P10.60 | Current alarm number | 0~4294967295 | | |
| P10.61 | Current fault number | 0~4294967295 | | |
| P10.62 | Last fault number | 0~4294967295 | | |
| P10.63 | The first two fault numbers | 0~4294967295 | | |

■ Function: Indicate the inverter fault information, (refer to chapter 10.2 Troubleshooting)

| Parameter number | Function | Setting range | Unit | Factory Value |
|------------------|---------------------------|----------------------|------|---------------|
| P10.70 | S input terminal state | 0~4294967295 | | |
| P10.71 | AI1 terminal input value | -65535.000~65535.000 | % | |
| P10.72 | AI2 terminal input value | -65535.000~65535.000 | % | |
| P10.74 | Y terminal output state | 0~4294967295 | | |
| P10.75 | AO1 terminal output value | -65535.000~65535.000 | % | |
| P10.76 | AO2 terminal output value | -65535.000~65535.000 | % | |

■ Function: indicate external terminal information

| Parameter number | Function | Setting range | Unit | Factory Value |
|------------------|------------------------|-----------------|------|---------------|
| P10.78 | Pulse input frequency | 0.000~10000.000 | kHz | |
| P10.79 | Pulse output frequency | 0.000~10000.000 | kHz | |

■ Function: Indicate pulse input and output frequency

| Parameter number | Function | Setting range | Unit | Factory Value |
|------------------|---------------|--------------------|------|---------------|
| P10.80 | Encoder count | 0~4294967295 | | |
| P10.81 | Encoder speed | -9999.000~9999.000 | Hz | |
| P10.82 | Encoder angle | 0.0~359.9 | deg | |

■ Function: indicate encoder status

| Parameter number | Function | Setting range | Unit | Factory Value |
|------------------|-------------|------------------------|------|---------------|
| P10.90 | Set value 1 | -999999.000~999999.000 | % | |
| P10.91 | Set value 2 | -999999.000~999999.000 | % | |
| P10.92 | Set value 3 | -999999.000~999999.000 | % | |

■ Function: Indicate the set value, see Figure 6-2-1

| Parameter number | Function | Setting range | Unit | Factory Value |
|------------------|-----------------|----------------------|------|---------------|
| P10.98 | Display value 1 | -99999.000~99999.000 | | |
| P10.99 | Display value 2 | -99999.000~99999.000 | | |

■ Function: indicate the display value (see P01.68 ~ P01.69 for the source of the display value)

6.10 Group 11 parameters: fault record

| Parameter number | Function | Setting range | Unit | Factory Value |
|------------------|---|----------------------|------|---------------|
| P11.10 | Current fault output frequency | -999999.0~999999.0 | Hz | 0.0 |
| P11.11 | Current fault output current | -999999.00~999999.00 | A | 0.00 |
| P11.12 | Current fault bus voltage | -999999.0~999999.0 | V | 0.0 |
| P11.13 | Current fault inverter temperature | -999999~999999 | ℃ | 0 |
| P11.14 | Current fault S terminal state | -999999~999999 | | 0 |
| P11.15 | Current fault Y terminal state | -999999~999999 | | 0 |
| P11.16 | Accumulated power-on time of the current fault | 0.000~4294967.295 | h | 0.000 |
| P11.20 | Output frequency of last fault | -999999.0~999999.0 | Hz | 0.0 |
| P11.21 | Output current of last fault | -999999.00~999999.00 | A | 0.00 |
| P11.22 | Bus voltage of last fault | -999999.0~999999.0 | V | 0.0 |
| P11.23 | Inverter temperature of last fault | -999999~999999 | ℃ | 0 |
| P11.24 | S-terminal state of last fault | -999999~999999 | | 0 |
| P11.25 | Y terminal state of last fault | -999999~999999 | | 0 |
| P11.26 | Accumulated power-on time of the last fault | 0.000~4294967.295 | h | 0.000 |
| P11.30 | Output frequency of the first two faults | -999999.0~999999.0 | Hz | 0.0 |
| P11.31 | Output current of the first two faults | -999999.00~999999.00 | A | 0.00 |
| P11.32 | Bus voltage of the first two faults | -999999.0~999999.0 | V | 0.0 |
| P11.33 | Inverter temperature of the first two faults | -999999~999999 | ℃ | 0 |
| P11.34 | S terminal state of the first two faults | -999999~999999 | | 0 |
| P11.35 | Y terminal state of th first two faults | -999999~999999 | | 0 |
| P11.36 | Accumulated power-on time of the first two faults | 0.000~4294967.295 | h | 0.000 |

■ Function: record fault information

Function parameter description

6.11 Group 12 parameters: free parameters

| Parameter number | Function | Setting range | Unit | Factory Value |
|------------------|--|------------------------|------|---------------|
| P12.00 ~ P12.19 | Free parameter 1 ~ Free parameter 20 | -999999.000~999999.000 | | 0.000 |
| P12.90 ~ P12.99 | Free parameter 91 ~ Free parameter 100 | -999999.000~999999.000 | | 0.000 |

■ Function: As an interface or intermediate quantity, expand system functions

➢ Principle explanation:
 P12.00 ~ P12.19, P12.90 ~ P12.94, automatically save the current value when power off.
 P12.95 ~ P12.99: Set the parameter number. The value of P12.90 ~ P12.94 at power-on is given to the parameter number set in P12.95 ~ P12.99.
 Only P12.90 ~ P12.99 parameters are automatically saved after power off.

6.12 Group 13 parameters: function output

| Parameter number | Function | Setting range | Unit | Factory Value |
|------------------|-------------------|---------------|------|---------------|
| P13.00 | Comparator output | 0~4294967295 | | 0 |
| P13.01 | Logic output | 0~4294967295 | | 0 |

■ Function: Indicate comparator output (see P16.00 ~ P16.35), logic output result (see P16.36 ~ P16.75)

➢ Comparator output: store all comparator results, bit0 stores comparator 1 results, bit1 stores comparator 2 results, ...
 ➢ Logic output: store all logical unit results, bit0 stores logical unit 1 results, bit1 stores logical unit 2 results, ...

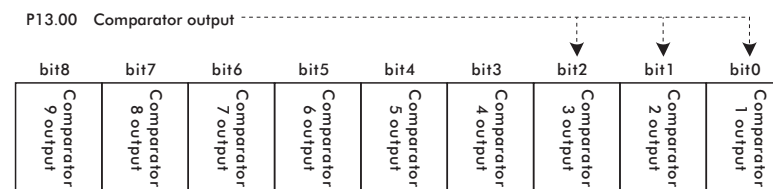

Figure 6-12-1 indicates the output of the comparator

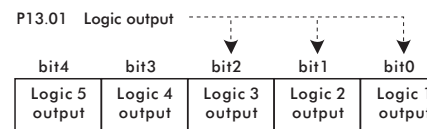

Figure 6-12-2 Indicate the logic output result

| Parameter number | Function | Setting range | Unit | Factory Value |
|------------------|--------------------------------|------------------------|------|---------------|
| P13.02 | Linear transformation 1 result | -999999.000~999999.000 | | 0.000 |
| P13.03 | Linear transformation 2 result | -999999.000~999999.000 | | 0.000 |

■ Function: Indicate the result of linear transformation (see P17.00 ~ P17.09)

Function parameter description

| Parameter number | Function | Setting range | Unit | Factory Value |
|------------------|--------------------------------------|------------------------|------|---------------|
| P13.10 | Single arithmetic operation 1 output | -999999.000~999999.000 | | 0.000 |
| P13.11 | Single arithmetic operation 2 output | -999999.000~999999.000 | | 0.000 |
| P13.12 | Single arithmetic operation 3 output | -999999.000~999999.000 | | 0.000 |
| P13.13 | Single arithmetic operation 4 output | -999999.000~999999.000 | | 0.000 |
| P13.14 | Single arithmetic operation 5 output | -999999.000~999999.000 | | 0.000 |

■ Function: Indicate the output result of single arithmetic operation (P17.16 ~ P17.25)

| Parameter number | Function | Setting range | Unit | Factory Value |
|------------------|-------------------------|------------------------|------|---------------|
| P13.15 | Math operation 1 output | -999999.000~999999.000 | | 0.000 |
| P13.16 | Math operation 2 output | -999999.000~999999.000 | | 0.000 |
| P13.17 | Math operation 3 output | -999999.000~999999.000 | | 0.000 |
| P13.18 | Math operation 4 output | -999999.000~999999.000 | | 0.000 |

■ Function: Indicate the output result of mathematical operation (see P17.26 ~ P17.45)

| Parameter number | Function | Setting range | Unit | Factory Value |
|------------------|---------------------|---------------|------|---------------|
| P13.40 | Comparator 1 output | 0~1 | | 0 |
| P13.41 | Comparator 2 output | 0~1 | | 0 |
| P13.42 | Comparator 3 output | 0~1 | | 0 |
| P13.43 | Comparator 4 output | 0~1 | | 0 |
| P13.44 | Comparator 5 output | 0~1 | | 0 |
| P13.45 | Comparator 6 output | 0~1 | | 0 |
| P13.46 | Comparator 7 output | 0~1 | | 0 |
| P13.47 | Comparator 8 output | 0~1 | | 0 |
| P13.48 | Comparator 9 output | 0~1 | | 0 |

■ Function: Indicate the bit corresponding to the output of a single comparator (see P16.00 ~ P16.35)

| Parameter number | Function | Setting range | Unit | Factory Value |
|------------------|----------------|---------------|------|---------------|
| P13.50 | Logic 1 output | 0~1 | | 0 |
| P13.51 | Logic 2 output | 0~1 | | 0 |

■ Function: Indicate the bit corresponding to the output of a single logic unit (see P16.36 ~ P16.51)

| Parameter number | Function | Setting range | Unit | Factory Value |
|------------------|--------------------------|---------------|------|---------------|
| P13.60 | Timer 1 current counting | 0~4294967295 | | 0 |
| P13.61 | Timer 1 current value | 0~65535 | | 0 |
| P13.62 | Timer 1 current stage | 0~16 | | 0 |
| P13.63 | Timer 2 current counting | 0~4294967295 | | 0 |
| P13.64 | Timer 2 current value | 0~65535 | | 0 |
| P13.65 | Timer 2 current stage | 0~16 | | 0 |

■ Function: Indicate the timer result (see P18.00 ~ P18.39)

- Current timer value: The timer counts, the count value can be suspended or cleared.
- Current state of timer: indicates the state of the timer stage, bit0 corresponds to stage 1, bit1 corresponds to stage 2, ...
- Timer current stage: indicates the current stage of the timer.

| Parameter number | Function | Setting range | Unit | Factory Value |
|------------------|---------------------------------|---------------|------|---------------|
| P13.92 | virtual address current value 1 | 0~4294967295 | | 0 |
| P13.93 | virtual address current value 2 | 0~4294967295 | | 0 |
| P13.94 | virtual address current value 3 | 0~4294967295 | | 0 |
| P13.95 | virtual address current value 4 | 0~4294967295 | | 0 |
| P13.96 | virtual address current value 5 | 0~4294967295 | | 0 |
| P13.97 | virtual address current value 6 | 0~4294967295 | | 0 |
| P13.98 | virtual address current value 7 | 0~4294967295 | | 0 |

■ Function: virtual address receiving value, referring to P01.32~P01.38 for detailed functions

6.13 Group 14 parameters: encoder

| Parameter number | Function | Setting range | Unit | Factory Value |
|------------------|----------------------|------------------------|------|---------------|
| P14.01 | Encoder 1 resolution | 1~2147483647 | | 1024 |
| P14.02 | Encoder 1 direction | 0: Forward; 1: Reverse | | 0 |

■ Function: Set encoder parameters

6.14 Group 16 parameters: logic unit

| Parameter number | Function | Setting range | Unit | Factory Value |
|------------------|---|--|------|---------------|
| P16.00 | Comparator 1 input parameter selection | 0~65535 | | 0 |
| P16.01 | Comparator 1 comparison parameter selection | 0~65535 | | 0 |
| P16.02 | Comparator 1 configuration | 0: >; 1: <; 2: ≧; 3: ≦; 4: =; 5: ≈; 6: ≠ | | 0 |
| P16.03 | Comparator 1 delay time | 0.000~99999.000 | s | 0.000 |
| P16.04 | Comparator 2 input parameter selection | 0~65535 | | 0 |
| P16.05 | Comparator 2 comparison parameter selection | 0~65535 | | 0 |
| P16.06 | Comparator 2 configuration | 0: >; 1: <; 2: ≧; 3: ≦; 4: =; 5: ≈; 6: ≠ | | 0 |
| P16.07 | Comparator 2 delay time | 0.000~99999.000 | s | 0.000 |
| P16.08 | Comparator 3 input parameter selection | 0~65535 | | 0 |
| P16.09 | Comparator 3 comparison parameter selection | 0~65535 | | 0 |
| P16.10 | Comparator 3 configuration | 0: >; 1: <; 2: ≧; 3: ≦; 4: =; 5: ≈; 6: ≠ | | 0 |
| P16.11 | Comparator 3 delay time | 0.000~99999.000 | s | 0.000 |

| | | | | |
|--------|---|--|---|-------|
| P16.12 | Comparator 4 input parameter selection | 0~65535 | | 0 |
| P16.13 | Comparator 4 comparison parameter selection | 0~65535 | | 0 |
| P16.14 | Comparator 4 configuration | 0: >; 1: <; 2: ≥; 3: ≤; 4: =; 5: ≈; 6: ≠ | | 0 |
| P16.15 | Comparator 4 delay time | 0.000~99999.000 | s | 0.000 |
| P16.16 | Comparator 5 input parameter selection | 0~65535 | | 0 |
| P16.17 | Comparator 5 comparison parameter selection | 0~65535 | | 0 |
| P16.18 | Comparator 5 configuration | 0: >; 1: <; 2: ≥; 3: ≤; 4: =; 5: ≈; 6: ≠ | | 0 |
| P16.19 | Comparator 5 delay time | 0.000~99999.000 | s | 0.000 |
| P16.20 | Comparator 6 input parameter selection | 0~65535 | | 0 |
| P16.21 | Comparator 6 comparison parameter selection | 0~65535 | | 0 |
| P16.22 | Comparator 6 configuration | 0: >; 1: <; 2: ≥; 3: ≤; 4: =; 5: ≈; 6: ≠ | | 0 |
| P16.23 | Comparator 6 delay time | 0.000~99999.000 | s | 0.000 |
| P16.24 | Comparator 7 input parameter selection | 0~65535 | | 0 |
| P16.25 | Comparator 7 comparison parameter selection | 0~65535 | | 0 |
| P16.26 | Comparator 7 configuration | 0: >; 1: <; 2: ≥; 3: ≤; 4: =; 5: ≈; 6: ≠ | | 0 |
| P16.27 | Comparator 7 delay time | 0.000~99999.000 | s | 0.000 |
| P16.28 | Comparator 8 input parameter selection | 0~65535 | | 0 |
| P16.29 | Comparator 8 comparison parameter selection | 0~65535 | | 0 |
| P16.30 | Comparator 8 configuration | 0: >; 1: <; 2: ≥; 3: ≤; 4: =; 5: ≈; 6: ≠ | | 0 |

| | | | | |
|--------|---|--|---|-------|
| P16.31 | Comparator 8 delay time | 0.000~99999.000 | s | 0.000 |
| P16.32 | Comparator 9 input parameter selection | 0~65535 | | 0 |
| P16.33 | Comparator 9 comparison parameter selection | 0~65535 | | 0 |
| P16.34 | Comparator 9 configuration | 0: >; 1: <; 2: ≥; 3: ≤; 4: =; 5: ≈; 6: ≠ | | 0 |
| P16.35 | Comparator 9 delay time | 0.000~99999.000 | s | 0.000 |

Function: Set comparison operation

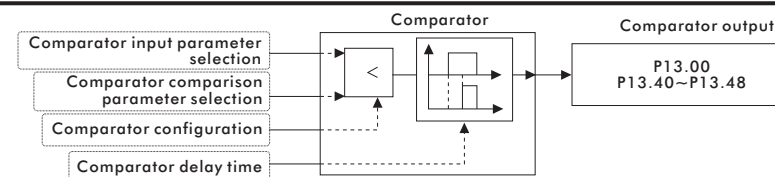

Figure 6-14-1 Comparator

- Comparator input parameter selection: this setting is the address. The address is the selected parameter number, and the actual value is determined by the current value of the selected parameter number.
- Comparator comparison parameter selection: this setting is the address. The address is the selected parameter number, and the actual value is determined by the current value of the selected parameter number.
- Comparator configuration: select the comparison relationship.
- Comparator delay time: After the delay time is reached, the comparator result is output.

Function parameter description

Function parameter description

| Parameter number | Function | Setting range | Unit | Factory Value |
|------------------|------------------------------------|---|------|---------------|
| P16.36 | Logic unit 1 parameter selection 1 | 0~65535 | | 0 |
| P16.37 | Logic unit 1 input bit selection 1 | 0~32 | | 0 |
| P16.38 | Logic unit 1 parameter selection 2 | 0~65535 | | 0 |
| P16.39 | Logic unit 1 input bit selection 2 | 0~32 | | 0 |
| P16.40 | Logic unit 1 parameter selection 3 | 0~65535 | | 0 |
| P16.41 | Logic unit 1 input bit selection 3 | 0~32 | | 0 |
| P16.42 | Logical unit 1 configuration 1 | 0: No effect; 1: And; 2: OR; 3: NAND; 4: NOR; 5: XOR | | 0 |
| P16.43 | Logical unit 1 configuration 2 | 0: No effect; 1: And; 2: OR; 3: NAND; 4: NOR; 5: XOR | | 0 |
| P16.44 | Logic unit 2 parameter selection 1 | 0~65535 | | 0 |
| P16.45 | Logic unit 2 input bit selection 1 | 0~32 | | 0 |
| P16.46 | Logic unit 2 parameter selection 2 | 0~65535 | | 0 |
| P16.47 | Logic unit 2 input bit selection 2 | 0~32 | | 0 |
| P16.48 | Logic unit 2 parameter selection 3 | 0~65535 | | 0 |
| P16.49 | Logic unit 2 input bit selection 3 | 0~32 | | 0 |
| P16.50 | Logical unit 2 configuration 1 | 0: No effect; 1: And; 2: OR; 3: NAND; 4: NOR; 5: XOR | | 0 |
| P16.51 | Logical unit 2 configuration 2 | 0: No effect; 1: And; 2: OR; 3: NAND; 4: NOR; 5: XOR | | 0 |

Function: Set logic function

- Logic unit parameter selection: this setting is the address. The address is the selected parameter number, and the actual value is determined by the current value of the selected parameter number.
- Logic unit input bit selection: select the bit selection of logic operation parameters, 0 means bit0, 1 means bit1 ...
- Logic unit configuration 1: configure logical operation of logic unit parameters.

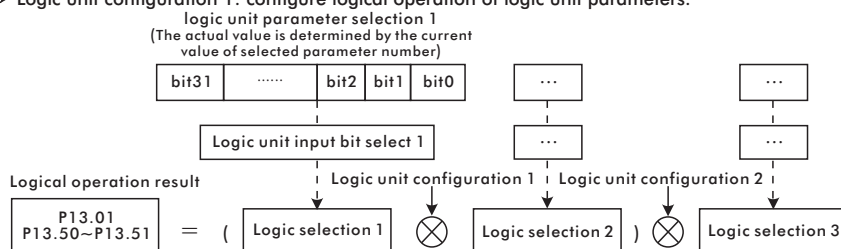

Figure 6-14-2 logic operation

| Parameter number | Function | Setting range | Unit | Factory Value |
|------------------|-----------------------------------|--|------|---------------|
| P16.76 | Selector 1 parameter source | 0~65535 | | 0 |
| P16.77 | Selector 1 setting | 0~16:numerical setting; 200~65535: address | | 0 |
| P16.78 | Selector 1 destination parameters | 0~65535 | | 0 |
| P16.79 | Selector 2 parameter source | 0~65535 | | 0 |
| P16.80 | Selector 2 setting | 0~16:numerical setting; 200~65535: address | | 0 |
| P16.81 | Selector 2 destination parameters | 0~65535 | | 0 |
| P16.82 | Selector 3 parameter source | 0~65535 | | 0 |
| P16.83 | Selector 3 setting | 0~16:numerical setting; 200~65535: address | | 0 |
| P16.84 | Selector 3 destination parameters | 0~65535 | | 0 |
| P16.85 | Selector 4 parameter source | 0~65535 | | 0 |
| P16.86 | Selector 4 setting | 0~16:numerical setting; 200~65535: address | | 0 |
| P16.87 | Selector 4 destination parameters | 0~65535 | | 0 |
| P16.88 | Selector 5 parameter source | 0~65535 | | 0 |
| P16.89 | Selector 5 setting | 0~16:numerical setting; 200~65535: address | | 0 |
| P16.90 | Selector 5 destination parameters | 0~65535 | | 0 |
| P16.91 | Selector 6 parameter source | 0~65535 | | 0 |
| P16.92 | Selector 6 setting | 0~16:numerical setting; 200~65535: address | | 0 |
| P16.93 | Selector 6 destination parameters | 0~65535 | | 0 |
| P16.94 | Selector 7 parameter source | 0~65535 | | 0 |
| P16.95 | Selector 7 setting | 0~16:numerical setting; 200~65535: address | | 0 |
| P16.96 | Selector 7 destination parameters | 0~65535 | | 0 |
| P16.97 | Selector 8 parameter source | 0~65535 | | 0 |
| P16.98 | Selector 8 setting | 0~16:numerical setting; 200~65535: address | | 0 |
| P16.99 | Selector 8 destination parameters | 0~65535 | | 0 |

Function: Set comparison operation

- Principle explanation: As shown in figure 6-14-3, when it sets to 0~16, selecting an address from 16 consecutive addresses with the selector parameter source as the first address, and pass the current value of the address to the selector destination parameter. when it sets to 200~65535 as an address, this address is the selected parameter number, and the actual value is determined by the current value of the selected parameter number.

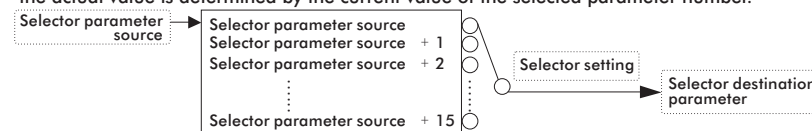

Figure 6-14-3 Selector

- For example: P16.76 = 250, P16.78 = 270
- When P16.77 = 0, the data of parameter P02.50 is transferred to P02.70;
- When P16.77 = 1, the data of parameter P02.51 is transferred to P02.70;
- When P16.77 = 2, the data of parameter P02.52 is transferred to P02.70;
-
- When P16.77 = 13, the data of parameter P02.63 is transferred to P02.70;
- When P16.77 = 14, the data of parameter P02.64 is transferred to P02.70;
- When P16.77 = 15, the data of parameter P02.65 is transferred to P02.70;

Function parameter description

Function parameter description

6.15 Group 17 parameters: mathematical operations

| Parameter number | Function | Setting range | Unit | Factory Value |
|------------------|--|------------------------|------|---------------|
| P17.00 | Linear transformation 1 parameter source | 0~65535 | | 0 |
| P17.01 | Linear transformation 1 X1 | -999999.000~999999.000 | | 0.000 |
| P17.02 | Linear transformation 1 X2 | -999999.000~999999.000 | | 50.000 |
| P17.03 | Linear transformation 1 Y1 | -999999.000~999999.000 | | 0.000 |
| P17.04 | Linear transformation 1 Y2 | -999999.000~999999.000 | | 1500.000 |
| P17.05 | Linear transformation 2 parameter source | 0~65535 | | 0 |
| P17.06 | Linear transformation 2 X1 | -999999.000~999999.000 | | 0.000 |
| P17.07 | Linear transformation 2 X2 | -999999.000~999999.000 | | 0.000 |
| P17.08 | Linear transformation 2 Y1 | -999999.000~999999.000 | | 0.000 |
| P17.09 | Linear transformation 2 Y2 | -999999.000~999999.000 | | 0.000 |

■ Function: Set linear transformation operation

➤ Principle explanation:

As shown in Figure 6-15-1, the source parameter of the linear transformation parameter is set, and the current value of the reference parameter is used as the x input. Linear relationship setting (modify parameters P17.01-17.04 or parameters P17.05-P17.09).

➤ Example: Different output frequencies correspond to different speeds

(0~50Hz corresponds to 0~1500rpm), the setting parameters are as follows:

- P17.00 = 1021 (source of linear transformation 1 parameter is output frequency)
- P17.01 = 0 (linear transformation 1 X1 is 0)
- P17.02 = 50 (linear transformation 1 X2 is 50)
- P17.03 = 0 (linear transformation 1 Y1 is 0)
- P17.04 = 1500 (linear transformation 1 Y2 is 1500)
- P13.02 = Linear transformation 1 result

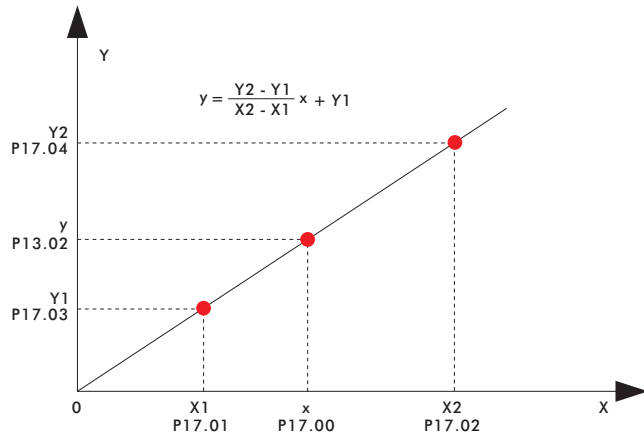

Figure 6-15-1 Linear transformation

| Parameter number | Function | Setting range | Unit | Factory Value |
|------------------|---|--|------|---------------|
| P17.16 | Single arithmetic operation 1 parameter source | 0~65535 | | 0 |
| P17.17 | Single arithmetic operation 1 operation setting | 0: ABS; 1: Sqrt; 2: Sin; 3: Cos; 4: Power2; 5: Power3; 6: Random; 7: Bitwise NOT; 8: 2 to the n; 10: If less than 0, it means 0. If greater than 0, it means 0. 11: If greater than 0, it means 0. If less than 0, it means 0. | | 0 |
| P17.18 | Single arithmetic operation 2 parameter source | 0~65535 | | 0 |
| P17.19 | Single arithmetic operation 2 operation setting | 0: ABS; 1: Sqrt; 2: Sin; 3: Cos; 4: Power2; 5: Power3; 6: Random; 7: Bitwise NOT; 8: 2 to the n; 10: If less than 0, it means 0. If greater than 0, it means 0. 11: If greater than 0, it means 0. If less than 0, it means 0. | | 0 |
| P17.20 | Single arithmetic operation 3 parameter source | 0~65535 | | 0 |
| P17.21 | Single arithmetic operation 3 operation setting | 0: ABS; 1: Sqrt; 2: Sin; 3: Cos; 4: Power2; 5: Power3; 6: Random; 7: Bitwise NOT; 8: 2 to the n; 10: If less than 0, it means 0. If greater than 0, it means 0. 11: If greater than 0, it means 0. If less than 0, it means 0. | | 0 |
| P17.22 | Single arithmetic operation 4 parameter source | 0~65535 | | 0 |
| P17.23 | Single arithmetic operation 4 operation setting | 0: ABS; 1: Sqrt; 2: Sin; 3: Cos; 4: Power2; 5: Power3; 6: Random; 7: Bitwise NOT; 8: 2 to the n; 10: If less than 0, it means 0. If greater than 0, it means 0. 11: If greater than 0, it means 0. If less than 0, it means 0. | | 0 |
| P17.24 | Single arithmetic operation 5 parameter source | 0~65535 | | 0 |
| P17.25 | Single arithmetic operation 5 operation setting | 0: ABS; 1: Sqrt; 2: Sin; 3: Cos; 4: Power2; 5: Power3; 6: Random; 7: Bitwise NOT; 8: 2 to the n; 10: If less than 0, it means 0. If greater than 0, it means 0. 11: If greater than 0, it means 0. If less than 0, it means 0. | | 0 |

■ Function: Set single arithmetic operation

➤ For example: P17.16=1200, P17.17=4, when P12.00=9.000, P13.10=81.000

Function parameter description

Function parameter description

| Parameter number | Function | Setting range | Unit | Factory Value |
|------------------|--|--|------|---------------|
| P17.26 | Mathematical operation 1 Parameter source 1 | 0~65535 | | 0 |
| P17.27 | Mathematical operation 1 Parameter source 2 | 0~65535 | | 0 |
| P17.28 | Mathematical operation 1 Parameter source 3 | 0~65535 | | 0 |
| P17.29 | Math operation 1 Operation setting 1 | 0:No effect; 1:+; 2:-; 3:*; 4:/; 5:Max; 6:Min; 7:Mean; 9:Bitwise AND; 10:Bitwise OR; 11:ANDN; 15:Edge signal source :(P17.29=15, detect the rising edge of P17.26 source, P17.30=15, when the result of P17.27 and P17.28 is not 0 by bitwise, resetting the rising edge) 16:Rearrange the values and increase 8 bits | | 0 |
| P17.30 | Math operation 1 Operation setting 2 | 0:No effect; 1:+; 2:-; 3:*; 4:/; 5:Max; 6:Min; 7:Mean; 9:Bitwise AND; 10:Bitwise OR; 11:ANDN; 15: Edge signal reset:(P17.29=15, detect the rising edge of P17.26 source, P17.30=15, when the result of P17.27 and P17.28 is not 0 by bitwise, resetting the rising edge) 16: Rearrange the values and decrease 8 bits | | 0 |
| P17.31 | Mathematical operation 2 Parameter source 1 | 0~65535 | | 0 |
| P17.32 | Mathematical operation 2 Parameter source 2 | 0~65535 | | 0 |
| P17.33 | Mathematical operation 2 Parameter source 3 | 0~65535 | | 0 |
| P17.34 | Math operation 2 Operation setting 1 | 0:No effect; 1:+; 2:-; 3:*; 4:/; 5:Max; 6:Min; 7:Mean; 9:Bitwise AND; 10:Bitwise OR; 11:ANDN; 15:Edge signal source :(P17.29=15, detect the rising edge of P17.26 source, P17.30=15, when the result of P17.27 and P17.28 is not 0 by bitwise, resetting the rising edge) 16:Rearrange the values and increase 8 bits | | 0 |

Function
parameter description

| | | | | |
|--------|--|--|--|---|
| P17.35 | Math operation 2 Operation setting 2 | 0:No effect; 1:+; 2:-; 3:*; 4:/; 5:Max; 6:Min; 7:Mean; 9:Bitwise AND; 10:Bitwise OR; 11:ANDN; 15: Edge signal reset:(P17.29=15, detect the rising edge of P17.26 source, P17.30=15, when the result of P17.27 and P17.28 is not 0 by bitwise, resetting the rising edge) 16: Rearrange the values and decrease 8 bits | | 0 |
| P17.36 | Mathematical operation 3 Parameter source 1 | 0~65535 | | 0 |
| P17.37 | Mathematical operation 3 Parameter source 2 | 0~65535 | | 0 |
| P17.38 | Mathematical operation 3 Parameter source 3 | 0~65535 | | 0 |
| P17.39 | Math operation 3 Operation setting 1 | 0:No effect; 1:+; 2:-; 3:*; 4:/; 5:Max; 6:Min; 7:Mean; 9:Bitwise AND; 10:Bitwise OR; 11:ANDN; 15:Edge signal source :(P17.29=15, detect the rising edge of P17.26 source, P17.30=15, when the result of P17.27 and P17.28 is not 0 by bitwise, resetting the rising edge) 16:Rearrange the values and increase 8 bits | | 0 |
| P17.40 | Math operation 3 Operation setting 2 | 0:No effect; 1:+; 2:-; 3:*; 4:/; 5:Max; 6:Min; 7:Mean; 9:Bitwise AND; 10:Bitwise OR; 11:ANDN; 15: Edge signal reset:(P17.29=15, detect the rising edge of P17.26 source, P17.30=15, when the result of P17.27 and P17.28 is not 0 by bitwise, resetting the rising edge) 16: Rearrange the values and decrease 8 bits | | 0 |
| P17.41 | Mathematical operation 4 Parameter source 1 | 0~65535 | | 0 |
| P17.42 | Mathematical operation 4 Parameter source 2 | 0~65535 | | 0 |
| P17.43 | Mathematical operation 4 Parameter source 3 | 0~65535 | | 0 |

Function
parameter description

| | | | | |
|--------|---|--|--|---|
| P17.44 | Math operation 4 Operation setting 1 | 0:No effect; 1:+; 2:-; 3:*; 4:/; 5:Max; 6:Min; 7:Mean; 9:Bitwise AND; 10:Bitwise OR; 11:ANDN; 15:Edge signal source :(P17.29=15, detect the rising edge of P17.26 source, P17.30=15, when the result of P17.27 and P17.28 is not 0 by bitwise, resetting the rising edge) 16:Rearrange the values and increase 8 bits | | 0 |
| P17.45 | Math operation 4 Operation setting 2 | 0:No effect; 1:+; 2:-; 3:*; 4:/; 5:Max; 6:Min; 7:Mean; 9:Bitwise AND; 10:Bitwise OR; 11:ANDN; 15: Edge signal reset:(P17.29=15, detect the rising edge of P17.26 source, P17.30=15, when the result of P17.27 and P17.28 is not 0 by bitwise, resetting the rising edge) 16: Rearrange the values and decrease 8 bits | | 0 |

■ Function: Set up math operation

- Source of mathematical operation parameters:
this setting is the address. The address is the selected parameter number, and the actual value is determined by the current value of the selected parameter number.
- Math operation setting: set math operation.

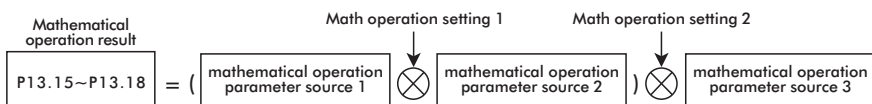

Figure 6-15-2 mathematical operation

For example: P17.26 = 1201, P17.27 = 1202, P17.28 = 1203, P17.29 = 1, P17.30 = 3
When P12.01 = 2.000, P12.02 = 3.000, P12.03 = 5.000,
the calculation result P13.15 = (2.000 + 3.000) * 5.000 = 25.000

- Edge signal .
For example: When the output frequency reaches 50Hz, the relay pulls in. When the output frequency is less than 50Hz, the relay keeps pull in. Only when the inverter stops, the relay will disconnect.

| Parameter number | Function | Setting Value |
|------------------|-----------------------------------|---------------|
| P03.00 | Start command source | 3 |
| P03.30 | Y1 terminal source | 1341 |
| P12.00 | Free parameter 1 | 50 |
| P12.01 | Free parameter 2 | 1 |
| P12.02 | Free parameter 3 | 0.001 |
| P16.00 | Comparator 1 input parameter | 1020 |
| P16.01 | Comparator 1 comparison parameter | 1200 |
| P16.02 | Comparator 1 configuration | 4 |

| | | |
|--------|---|------|
| P16.04 | Comparator 2 input parameter | 1315 |
| P16.05 | Comparator 2 comparison parameter | 1202 |
| P16.06 | Comparator 2 configuration | 4 |
| P16.36 | Logic unit 1 parameter selection 1 | 1070 |
| P16.37 | Logic unit 1 input bit selection 1 | 0 |
| P16.38 | Logic unit 1 parameter selection 2 | 1201 |
| P16.39 | Logic unit 1 input bit selection 2 | 0 |
| P16.42 | Logical unit 1 configuration 1 | 5 |
| P17.26 | Mathematical operation 1 parameter source 1 | 1340 |
| P17.27 | Mathematical operation 1 parameter source 2 | 1350 |
| P17.28 | Mathematical operation 1 parameter source 3 | 1201 |
| P17.29 | Math operation 1 operation setting 1 | 15 |
| P17.30 | Math operation 1 operation setting 2 | 15 |

6.16 Group 18 parameters: timing control

| Parameter number | Function | Setting range | Unit | Factory Value |
|------------------|-------------------------|---|------|---------------|
| P18.00 | Timer 1 clock source | 0:1ms; 1:10ms; 2:100ms; 3:1s; 6:1h; 7:1day; 11~26: from S1 ~ S16, when S terminal is the rising edge, count plus 1; 27~42: from the 0~15 bits of virtual terminal P01.30, when the corresponding bit is the rising edge, count plus 1; 51~76: from S1~S16, when S terminal is the falling edge, count plus 1; 77~92: from the 0~15 bits of virtual terminal P01.30, when the corresponding bit is the falling edge, count plus 1; 200~3799: address | | 0 |
| P18.01 | Timer 1 working mode | 0: Stop at the end of a single run; 1 ~ 16: Set the start of the next cycle At the end of a single operation, the cycle starts automatically from the setting | | 0 |
| P18.02 | Timer 1 control command | bit0: Enable; bit1: Start counting; bit2: Pause counting; bit3: Clear counting | | 0 |
| P18.03 | Timer 1 set value | -1~4294967295 | | -1 |
| P18.04 | Timer 1 phase 1 time | 0~4294967295 | | 0 |
| P18.05 | Timer 1 phase 2 time | 0~4294967295 | | 0 |
| P18.06 | Timer 1 phase 3 time | 0~4294967295 | | 0 |
| P18.07 | Timer 1 phase 4 time | 0~4294967295 | | 0 |
| P18.08 | Timer 1 phase 5 time | 0~4294967295 | | 0 |
| P18.09 | Timer 1 phase 6 time | 0~4294967295 | | 0 |
| P18.10 | Timer 1 phase 7 time | 0~4294967295 | | 0 |
| P18.11 | Timer 1 phase 8 time | 0~4294967295 | | 0 |
| P18.12 | Timer 1 phase 9 time | 0~4294967295 | | 0 |
| P18.13 | Timer 1 phase 10 time | 0~4294967295 | | 0 |
| P18.14 | Timer 1 phase 11 time | 0~4294967295 | | 0 |
| P18.15 | Timer 1 phase 12 time | 0~4294967295 | | 0 |
| P18.16 | Timer 1 phase 13 time | 0~4294967295 | | 0 |
| P18.17 | Timer 1 phase 14 time | 0~4294967295 | | 0 |

Function parameter description

Function parameter description

| | | | | |
|--------|-------------------------|---|--|----|
| P18.18 | Timer 1 phase 15 time | 0~4294967295 | | 0 |
| P18.19 | Timer 1 phase 16 time | 0~4294967295 | | 0 |
| P18.20 | Timer 2 clock source | 0:1ms; 1:10ms; 2:100ms; 3:1s; 6:1h; 7:1day; 11~26: from S1 ~ S16, when S terminal is the rising edge, count plus 1; 27~42: from the 0~15 bits of virtual terminal P01.30, when the corresponding bit is the rising edge, count plus 1; 51~76: from S1~S16, when S terminal is the falling edge, count plus 1; 77~92: from the 0~15 bits of virtual terminal P01.30, when the corresponding bit is the falling edge, count plus 1; 200~3799: address | | 0 |
| P18.21 | Timer 2 working mode | 0: Stop at the end of a single run; 1 ~ 16: Set the start of the next cycle At the end of a single operation, the cycle starts automatically from the setting | | 0 |
| P18.22 | Timer 2 control command | bit0: Enable; bit1: Start counting; bit2: Pause counting; bit3: Clear counting | | 0 |
| P18.23 | Timer 2 set value | -1~4294967295 | | -1 |
| P18.24 | Timer 2 phase 1 time | 0~4294967295 | | 0 |
| P18.25 | Timer 2 phase 2 time | 0~4294967295 | | 0 |
| P18.26 | Timer 2 phase 3 time | 0~4294967295 | | 0 |
| P18.27 | Timer 2 phase 4 time | 0~4294967295 | | 0 |
| P18.28 | Timer 2 phase 5 time | 0~4294967295 | | 0 |
| P18.29 | Timer 2 phase 6 time | 0~4294967295 | | 0 |
| P18.30 | Timer 2 phase 7 time | 0~4294967295 | | 0 |
| P18.31 | Timer 2 phase 8 time | 0~4294967295 | | 0 |
| P18.32 | Timer 2 phase 9 time | 0~4294967295 | | 0 |
| P18.33 | Timer 2 phase 10 time | 0~4294967295 | | 0 |
| P18.34 | Timer 2 phase 11 time | 0~4294967295 | | 0 |
| P18.35 | Timer 2 phase 12 time | 0~4294967295 | | 0 |
| P18.36 | Timer 2 phase 13 time | 0~4294967295 | | 0 |
| P18.37 | Timer 2 phase 14 time | 0~4294967295 | | 0 |
| P18.38 | Timer 2 phase 15 time | 0~4294967295 | | 0 |
| P18.39 | Timer 2 phase 16 time | 0~4294967295 | | 0 |

Function: Set timer parameters

- Timer clock source: Set the timer clock source.
Set to 0 ~ 199, this setting is to select a specific time interval,
Set to 200 ~ 3799, this setting is the address.
The address is the selected parameter number, and the actual value is determined by the current value of the selected parameter number.
- Timer working mode: set to 0, it will not cycle after the end of a single run; set to N ($1 \leq N \leq 16$), after the end of a single run, it will automatically start to cycle from N until the timer is not enabled
- Timer control commands: bit0: enable; bit1: start counting, rising edge signal enable; bit2: pause counting; bit3: clear counting.
- Timer setting value: Set the timer count value.
- Timer phase time: set the timer duration of each phase of the timer.

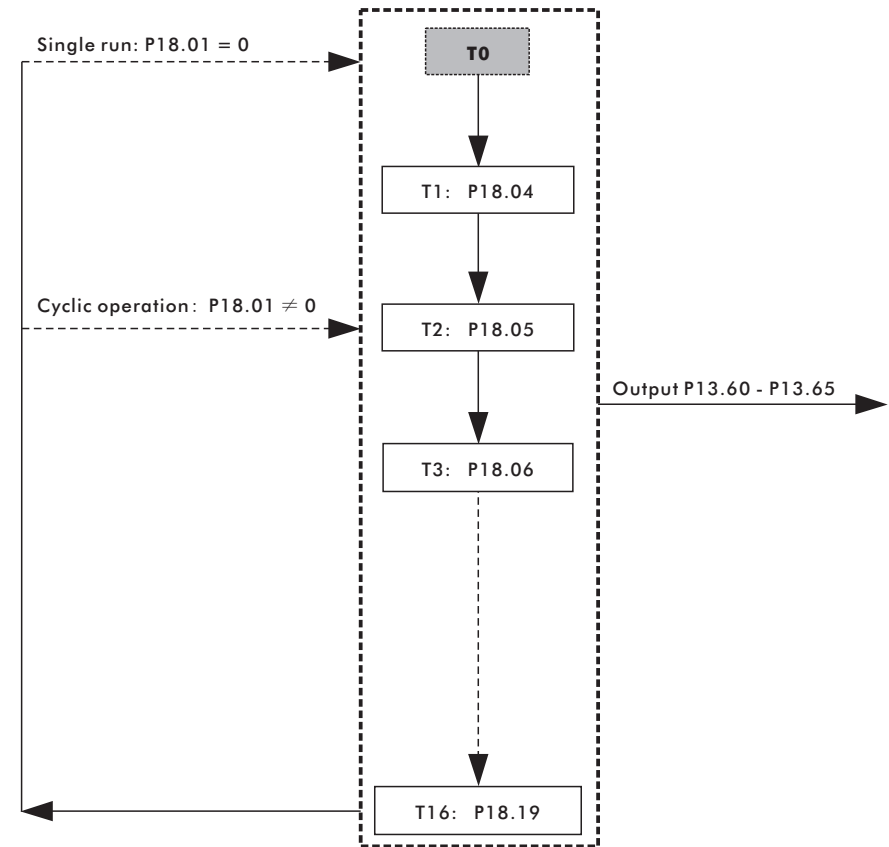

Figure 6-16-1 Timing control

CHAPTER 7 - The examples for macro of application

7.1 Multi-speed control operation

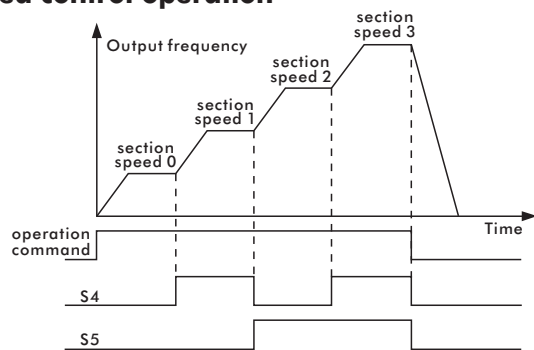

Figure 7-1 Multi-speed selection

- Example: The external terminals S4 and S5 control the four-stage speed switching, and the multi-stage speeds are set to 10HZ, 15HZ, 20HZ, 25HZ respectively.
 Step 1: Set P01.20 to 31, select multi-stage speed macro;
 Step 2: Set P03.00 to 3, select external terminal S1 to control start.

7.2 The internal control with eight periods of speed

- Example: timing control of eight-stage speed switching, setting multi-stage speeds as 5HZ, 10HZ, 15HZ, 20HZ, 25HZ, 30HZ, 35HZ, 40HZ; external terminal S4 controls multi-stage speed enable, S1 controls motor running.
 Step 1: Set P01.20 to 68, select the internal control eight-stage speed macro;
 Step 2: Set P03.00 to 3, select external terminal S1 to control start.
- Example: Timing control of eight-stage speed switching, setting multi-stage speeds as 5HZ, 10HZ, 15HZ, 20HZ, 25HZ, 30HZ, 35HZ, 40HZ; external terminal S4 controls multi-stage speed enable and motor start.
 Step 1: Set P01.20 to 68, select the internal control eight-stage speed macro;
 Step 2: Set P03.00 to 6, select external terminal S4 to control start.

7.3 PID control operation

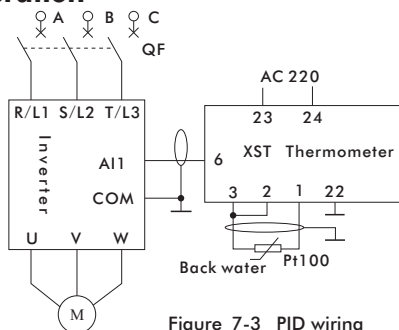

Figure 7-3 PID wiring

- Example: PID control operation, set value is multi-step speed, feedback uses AI1, external terminal S1 controls start and stop.
 Step 1: Set P01.20 to 32, select PID macro 1;
 Step 2: Set P01.39 to 0, the command source setting selects single command source mode;
 Step 3: Set P03.00 to 3 and select S1 as the source of the start command.
- Example: PID control operation, set value is AI2, feedback uses AI1, external terminal S1 controls start and stop.
 Step 1: Set P01.20 to 33, select PID Macro 2;
 Step 2: Set P01.39 to 0, the command source setting selects single command source mode;
 Step 3: Set P03.00 to 3 and select S1 as the source of the start command.

CHAPTER 8 - Application Macro

| No. | Name | S1 | S2 | S3 | S4 | S5 | Y1 | Y2 | Y3 | AI1 | AI2 | AO1 | AO2 | Keyboard | Communication |
|-----|--|----------|---------------------|---------------------|-------------------------|-------------------------|--|-------|-------|----------------|-----------|------------------|----------------|----------------|--------------------------|
| 0-9 | User Macro 1-10 | x | x | x | x | x | x | x | x | x | x | x | x | x | x |
| 10 | Comprehensive Macro 1 | start up | Reverse and reverse | JOG | Segment speed selection | Segment speed selection | Running | Fault | Alarm | Set value | x | Output frequency | Output current | Start and stop | Start/stop/setting value |
| 11 | Comprehensive Macro 2 | start up | Forward and reverse | JOG | Segment speed selection | Segment speed selection | Running | Fault | Alarm | Set value | x | Output frequency | Output current | Start and stop | Start/stop/setting value |
| 12 | Comprehensive Macro 3 | start up | Stop | Forward and reverse | Segment speed selection | Segment speed selection | Running | Fault | Alarm | Set value | x | Output frequency | Output current | Start and stop | Start/stop/setting value |
| 13 | Comprehensive Macro 4 | start up | Stop | JOG | x | x | Running | Fault | Alarm | Feedback value | Set value | Output frequency | Output current | Start and stop | Start and stop |
| 20 | 1-line command macro 1 | start up | x | x | x | x | x | x | x | x | x | x | x | Start and stop | Start/stop/setting value |
| 21 | 2-line command macro 1 | start up | Reverse start | x | x | x | x | x | x | x | x | x | x | Start and stop | Start/stop/setting value |
| 22 | 2-line command macro 2 | start up | Forward and reverse | x | x | x | x | x | x | x | x | x | x | Start and stop | Start/stop/setting value |
| 23 | 3-line command macro 1 | start up | Reverse start | Stop | x | x | x | x | x | x | x | x | x | Start and stop | Start/stop/setting value |
| 24 | 3-line command macro 2 | start up | Forward and reverse | Stop | x | x | x | x | x | x | x | x | x | Start and stop | Start/stop/setting value |
| 30 | Main and auxiliary settings | x | x | x | x | x | x | x | x | Set value | x | x | x | x | Set value |
| 31 | Multi-stage speed macro | x | x | x | Segment speed selection | Segment speed selection | x | x | x | x | x | x | x | x | x |
| 32 | PID Macro 1 | x | x | x | x | x | x | x | x | Feedback value | x | x | x | x | x |
| 33 | PID Macro 2 | x | x | x | x | x | x | x | x | Feedback value | Set value | x | x | x | x |
| 50 | Speed Start macro | x | x | x | x | x | x | x | x | x | x | x | x | x | x |
| 51 | DC injection macro | x | x | x | x | x | x | x | x | x | x | x | x | x | x |
| 52 | Free parking macro | x | x | x | x | x | x | x | x | x | x | x | x | x | x |
| 53 | DC brake macro | x | x | x | x | x | x | x | x | x | x | x | x | x | x |
| 54 | Emergency acceleration macro | x | x | x | x | x | x | x | x | x | x | x | x | x | x |
| 55 | Emergency deceleration macro | x | x | x | x | x | x | x | x | x | x | x | x | x | x |
| 60 | Console switch macro | x | x | x | Segment speed selection | Segment speed selection | x | x | x | x | x | x | x | Set value | x |
| 61 | Frequency reach macro | x | x | x | x | x | Frequency reach | x | x | x | x | x | x | x | x |
| 62 | FDT macro | x | x | x | x | x | Frequency reach range | x | x | x | x | x | x | x | x |
| 63 | Acceleration and deceleration switching | x | x | x | x | x | x | x | x | x | x | x | x | x | x |
| 64 | Brake signal macro | x | x | x | x | x | Frequency too low | x | x | x | x | x | x | x | x |
| 65 | Release signal macro | x | x | x | x | x | Frequency reached and the current is too large | x | x | x | x | x | x | x | x |
| 66 | Break detection macro | x | x | x | x | x | Frequency reached and the current is too small | x | x | x | x | x | x | x | x |
| 67 | Signal loss macro | x | x | x | x | x | Detection signal is less than the threshold | x | x | x | x | x | x | x | x |
| 68 | Internal control eight-stage speed macro | x | x | x | Segment speed selection | | x | x | x | x | x | x | x | x | x |

Note: restore factory value before changing application macro!

8.1 Comprehensive Macro 1

Comprehensive Macro 1 (P01.20=10)

Multi-command source, multi-set value given mode, analog and digital output.

- Set frequency: main frequency AI1 + auxiliary frequency (multi-speed + communication).
- If JOG command is valid, run JOG frequency.
- Command source: start and stop, reverse start, JOG command.
- Use analog quantity AI1, AO1, AO2, external terminals S1 ~ S5.

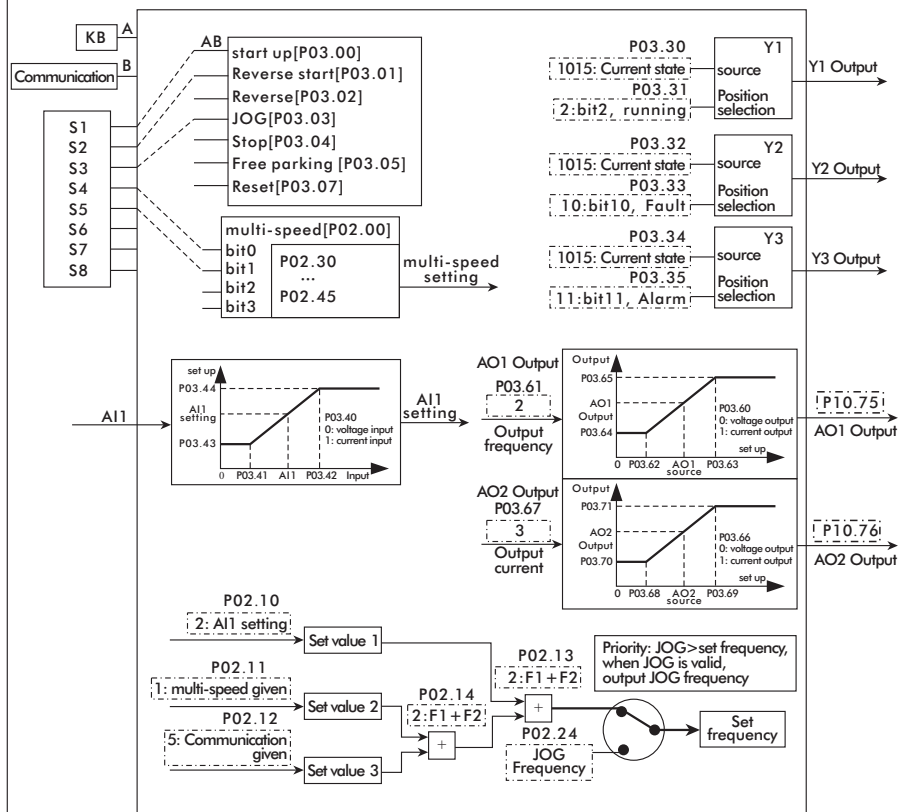

| Parameter No. | Function | Setting value | Note |
|---------------|-------------------|---------------|--|
| P02.24 | JOG Frequency | 10 | JOG frequency is set to 5Hz |
| P02.30 | Multi-speed 0 | 20 | Auxiliary frequency multi-speed 0 is set to 10Hz |
| P02.31 | Multi-speed 1 | 30 | Auxiliary frequency multi-speed 1 is set to 15Hz |
| P02.32 | Multi-speed 2 | 40 | Auxiliary frequency multi-speed 2 is set to 20Hz |
| P02.33 | Multi-speed 3 | 50 | Auxiliary frequency multi-speed 3 is set to 25Hz |
| P03.61 | AO1 signal source | 2 | Output frequency |
| P03.67 | AO2 signal source | 3 | Output current |

| | | | |
|--------|--------------------------------------|---------|---|
| P03.40 | AI1 signal type | 0 | AI1 signal type is voltage signal |
| P03.41 | AI1 low-end voltage (current) | 0.050 | 0.050V corresponds to 0Hz |
| P03.42 | AI1 high-end voltage (current) | 10.000 | 10.000V corresponds to 50Hz |
| P03.43 | AI1 low-end setting | 0.000 | AI1 low-end setting |
| P03.44 | AI1 high-end setting | 100.000 | AI1 high-end setting |
| P03.60 | AO1 signal type | 0 | AO1 signal type is voltage signal |
| P03.62 | AO1 low-end setting | 0.000 | AO1 low-end setting |
| P03.63 | AO1 high-end setting | 50.000 | AO1 high-end setting |
| P03.64 | AO1 low-end voltage (current) | 0.000 | 0.000V corresponds to 0Hz |
| P03.65 | AO1 high-end voltage (current) | 10.000 | 10.000V corresponds to 50Hz |
| P03.66 | AO2 signal type | 0 | AO2 signal type is voltage signal |
| P03.68 | AO2 low-end setting | 0.000 | AO2 low-end setting |
| P03.69 | AO2 high-end setting | 50.000 | AO2 high-end setting |
| P03.70 | AO2 low-end voltage (current) | 0.000 | 0.000V corresponds to 0Hz |
| P03.71 | AO2 high-end voltage (current) | 10.000 | 10.000V corresponds to 50Hz |
| P01.39 | Command mode | 1 | Multi-command source |
| P02.00 | Multi-speed source | 11000 | Multi-speed selection for external terminals S4, S5 |
| P02.10 | Set value source 1 | 2 | Set value source 1 select AI1 |
| P02.11 | Set value source 2 | 1 | Set value source 2 select multi-speed |
| P02.12 | Set value source 3 | 5 | Set value source 3 is communication |
| P02.13 | Set channel 1 relationship selection | 2 | Set the channel 1 relationship selection to F1 + F2 |
| P02.14 | Set channel 2 relationship selection | 2 | Set the channel 2 relationship selection to F1 + F2 |
| P03.00 | Start command source | 7 | Start command to select keyboard, communication, external terminal S1 |
| P03.01 | Reverse start command source | 8 | Reverse start command is selected as external terminal S2 |
| P03.03 | JOG command source | 16 | JOG command is selected as external terminal S3 |
| P03.30 | Y1 terminal source | 3 | Relay 1 comes from the current state is running |
| P03.32 | Y2 terminal source | 4 | Relay 2 comes from current state fault |
| P03.34 | Y3 terminal source | 5 | Relay 3 comes from the current state alarm |

Comprehensive Macro 1

Comprehensive Macro 1

8.2 Comprehensive Macro 2

Comprehensive Macro 2 (P01.20=11)

Multi-command source, the mode how multi-set value is given, analog and digital output.

- Set frequency: The main frequency AI1 + auxiliary frequency (multi-stage speed + communication) is given.
- If JOG command is valid, run JOG frequency.
- Command source: start and stop, forward and reverse, JOG command.
- Use analog quantity AI1, AO1, AO2, external terminals S1 ~ S5.

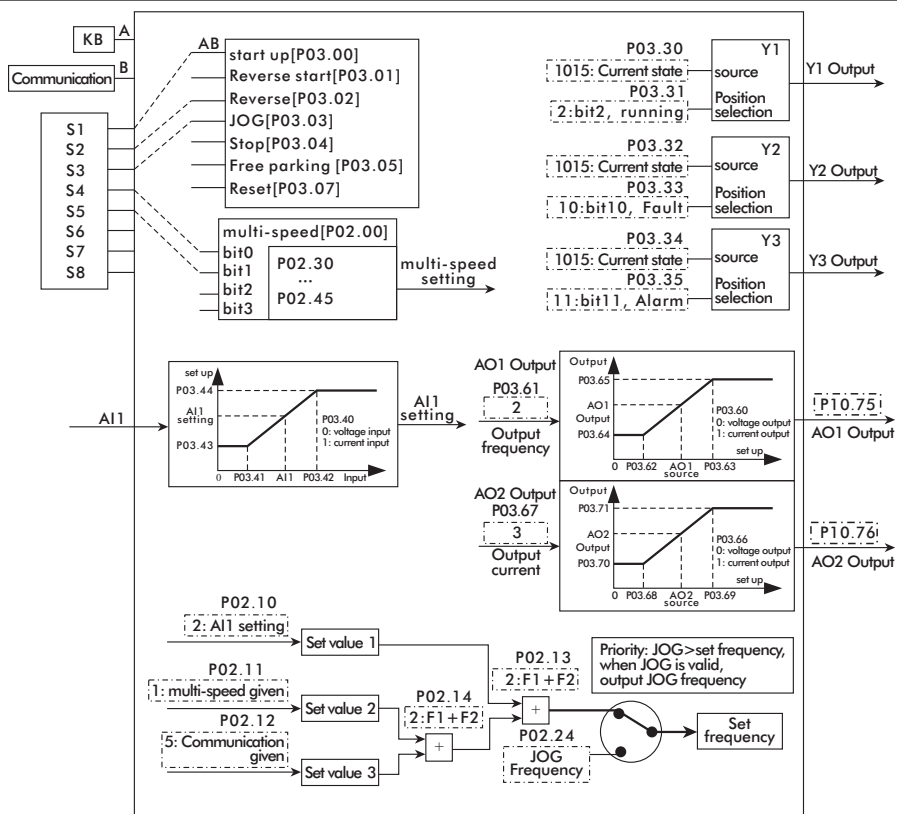

| Parameter No. | Function | Setting value | Note |
|---------------|---------------|---------------|--|
| P02.24 | JOG Frequency | 10 | JOG frequency is set to 5Hz |
| P02.30 | Multi-speed 0 | 20 | Auxiliary frequency multi-speed 0 is set to 10Hz |
| P02.31 | Multi-speed 1 | 30 | Auxiliary frequency multi-speed 1 is set to 15Hz |
| P02.32 | Multi-speed 2 | 40 | Auxiliary frequency multi-speed 2 is set to 20Hz |
| P02.33 | Multi-speed 3 | 50 | Auxiliary frequency multi-speed 3 is set to 25Hz |

| | | | |
|--------|--------------------------------------|---------|---|
| P03.61 | AO1 signal source | 2 | Output frequency |
| P03.67 | AO2 signal source | 3 | Output current |
| P03.40 | AI1 signal type | 0 | AI1 signal type is voltage signal |
| P03.41 | AI1 low-end voltage (current) | 0.050 | 0.050V corresponds to 0Hz |
| P03.42 | AI1 high-end voltage (current) | 10.000 | 10.000V corresponds to 50Hz |
| P03.43 | AI1 low-end setting | 0.000 | AI1 low-end setting |
| P03.44 | AI1 high-end setting | 100.000 | AI1 high-end setting |
| P03.60 | AO1 signal type | 0 | AO1 signal type is voltage signal |
| P03.62 | AO1 low-end setting | 0.000 | AO1 low-end setting |
| P03.63 | AO1 high-end setting | 50.000 | AO1 high-end setting |
| P03.64 | AO1 low-end voltage (current) | 0.000 | 0.000V corresponds to 0Hz |
| P03.65 | AO1 high-end voltage (current) | 10.000 | 10.000V corresponds to 50Hz |
| P03.66 | AO2 signal type | 0 | AO2 signal type is voltage signal |
| P03.68 | AO2 low-end setting | 0.000 | AO2 low-end setting |
| P03.69 | AO2 high-end setting | 50.000 | AO2 high-end setting |
| P03.70 | AO2 low-end voltage (current) | 0.000 | 0.000V corresponds to 0Hz |
| P03.71 | AO2 high-end voltage (current) | 10.000 | 10.000V corresponds to 50Hz |
| P01.39 | Command mode | 1 | Multi-command source mode |
| P02.00 | Multi-speed source | 11000 | The multi-stage speed is selected as S4, S5 |
| P02.10 | Set value source 1 | 2 | Set value source 1 select AI1 |
| P02.11 | Set value source 2 | 1 | Set value source 2 select multi-speed |
| P02.12 | Set value source 3 | 5 | Set value source 3 is communication |
| P02.13 | Set channel 1 relationship selection | 2 | Set the channel 1 relationship selection to F1 + F2 |
| P02.14 | Set channel 2 relationship selection | 2 | Set the channel 2 relationship selection to F1 + F2 |
| P03.00 | Start command source | 7 | Start command to select keyboard, communication, external terminal S1 |
| P03.02 | Reverse command source | 8 | Reverse command is selected as external terminal S3 |
| P03.03 | JOG command source | 16 | JOG command is selected as external terminal S3 |
| P03.30 | Y1 terminal source | 3 | Relay 1 comes from the current state is running |
| P03.32 | Y2 terminal source | 4 | Relay 2 comes from current state fault |
| P03.34 | Y3 terminal source | 5 | Relay 3 comes from the current state alarm |

8.3 Comprehensive Macro 3

Comprehensive Macro 3 (P01.20=12)

Multi-command source, multi-set value given mode, analog and digital output.

- Set frequency: The main frequency AI1 + auxiliary frequency (multi-stage speed + communication) is given.
- Command source: start stop, stop, forward and reverse.
- Use analog quantity AI1, AO1, AO2, external terminals S1 ~ S5.

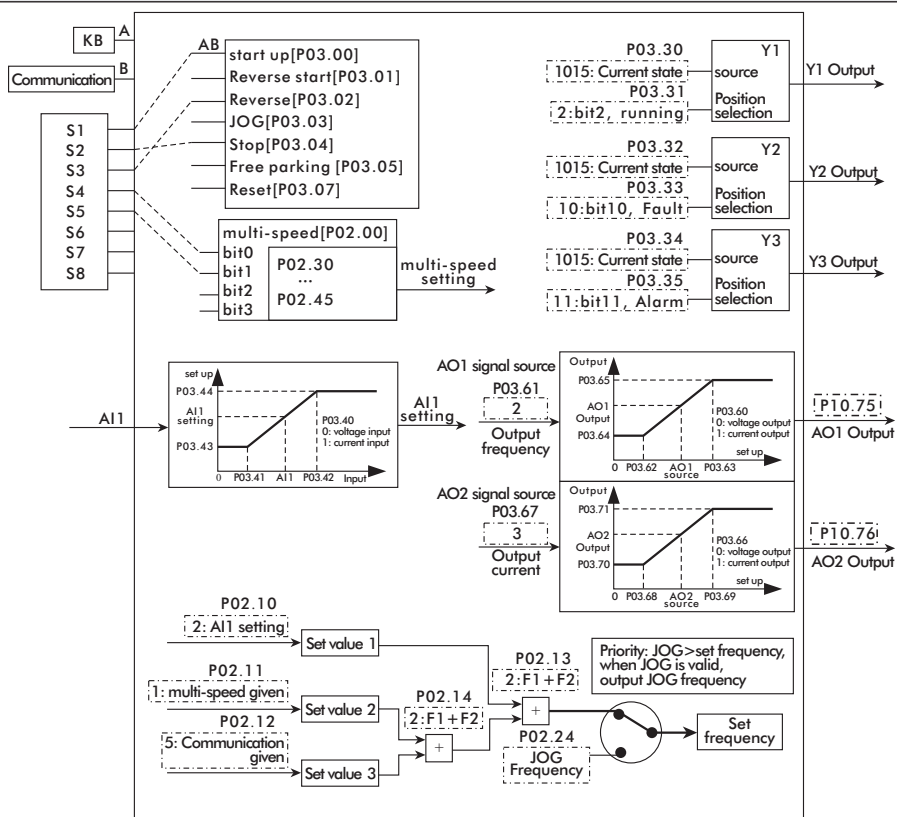

| Parameter No. | Function | Setting value | Note |
|---------------|---------------|---------------|--|
| P02.30 | Multi-speed 0 | 20 | Auxiliary frequency multi-speed 0 is set to 10Hz |
| P02.31 | Multi-speed 1 | 30 | Auxiliary frequency multi-speed 1 is set to 15Hz |
| P02.32 | Multi-speed 2 | 40 | Auxiliary frequency multi-speed 2 is set to 20Hz |
| P02.33 | Multi-speed 3 | 50 | Auxiliary frequency multi-speed 2 is set to 25Hz |

| | | | |
|--------|--------------------------------------|---------|---|
| P03.61 | AO1 signal source | 2 | Output frequency |
| P03.67 | AO2 signal source | 3 | Output current |
| P03.40 | AI1 signal type | 0 | AI1 signal type is voltage signal |
| P03.41 | AI1 low-end voltage (current) | 0.050 | 0.050V corresponds to 0Hz |
| P03.42 | AI1 high-end voltage (current) | 10.000 | 10.000V corresponds to 50Hz |
| P03.43 | AI1 low-end setting | 0.000 | AI1 low-end setting |
| P03.44 | AI1 high-end setting | 100.000 | AI1 high-end setting |
| P03.60 | AO1 signal type | 0 | AO1 signal type is voltage signal |
| P03.62 | AO1 low-end setting | 0.000 | AO1 low-end setting |
| P03.63 | AO1 high-end setting | 50.000 | AO1 high-end setting |
| P03.64 | AO1 low-end voltage (current) | 0.000 | 0.000V corresponds to 0Hz |
| P03.65 | AO1 high-end voltage (current) | 10.000 | 10.000V corresponds to 50Hz |
| P03.66 | AO2 signal type | 0 | AO2 signal type is voltage signal |
| P03.68 | AO2 low-end setting | 0.000 | AO2 low-end setting |
| P03.69 | AO2 high-end setting | 50.000 | AO2 high-end setting |
| P03.70 | AO2 low-end voltage (current) | 0.000 | 0.000V corresponds to 0Hz |
| P03.71 | AO2 high-end voltage (current) | 10.000 | 10.000V corresponds to 50Hz |
| P01.39 | Command mode | 1 | Multi-command source mode |
| P02.00 | Multi-speed source | 11000 | Multi-speed selection for external terminals S4, S5 |
| P02.10 | Set value source 1 | 2 | Set value source 1 select AI1 |
| P02.11 | Set value source 2 | 1 | Set value source 2 select multi-speed |
| P02.12 | Set value source 3 | 5 | Set value source 3 select communication |
| P02.13 | Set channel 1 relationship selection | 2 | Set the channel 1 relationship selection to F1 + F2 |
| P02.14 | Set channel 2 relationship selection | 2 | Set the channel 2 relationship selection to F1 + F2 |
| P03.00 | Start command source | 7 | Start command to select keyboard, communication, external terminal S1 |
| P03.04 | Stop command source | 8 | Stop command is selected as external terminal S2 |
| P03.02 | Reverse command source | 16 | Reverse command is selected as external terminal S3 |
| P03.30 | Y1 terminal source | 3 | Relay 1 comes from the current state is running |
| P03.32 | Y2 terminal source | 4 | Relay 2 comes from current state fault |
| P03.34 | Y3 terminal source | 5 | Relay 3 comes from the current state alarm |

8.4 Comprehensive Macro 4

Comprehensive Macro 4(P01.20=13)

Multi-command source, PID main and auxiliary setting value given mode, analog and digital output.

- Set frequency: The main frequency AI2 + auxiliary frequency PID is given. PID setting: multi-step speed, PID feedback: AI1.
- If JOG command is valid, run JOG frequency.
- Command source: start stop, stop, JOG command.
- Use analog AI1, AI2, AO1, AO2, external terminals S1 ~ S3.

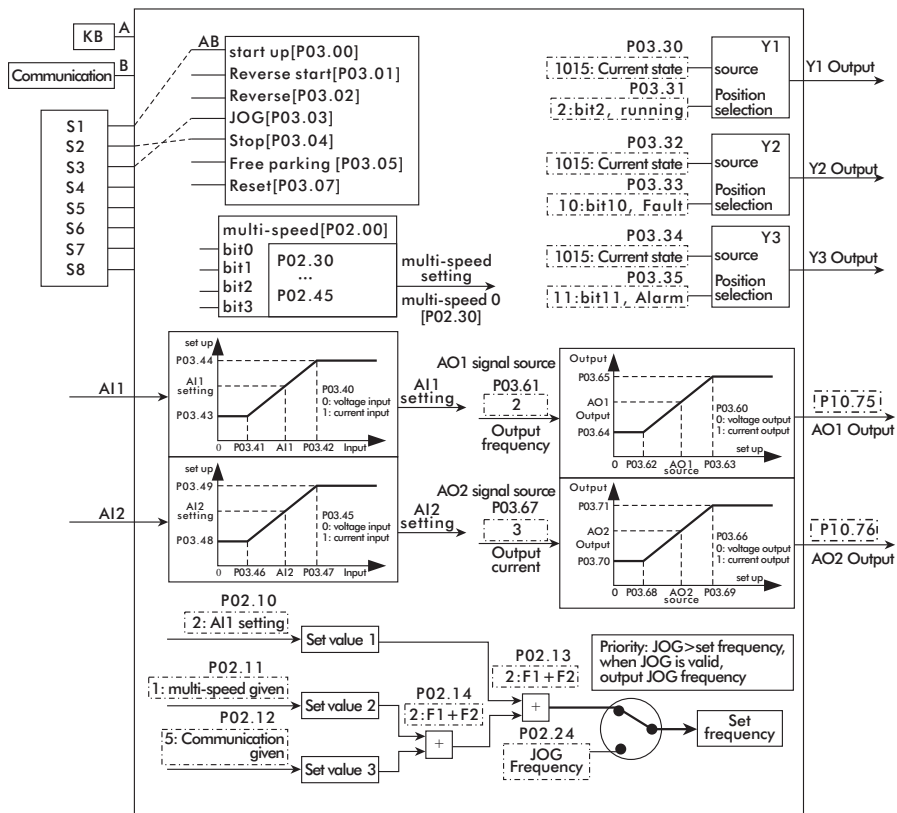

| Parameter No. | Function | Setting value | Note |
|---------------|---------------|---------------|-----------------------------|
| P02.24 | JOG Frequency | 10 | JOG frequency is set to 5Hz |
| P02.30 | Multi-speed 0 | 20 | PID setting is set to 10HZ |

| | | | |
|--------|--------------------------------|---------|-----------------------------------|
| P03.61 | AO1 signal source | 2 | Output frequency |
| P03.67 | AO2 signal source | 3 | Output current |
| P03.40 | AI1 signal type | 0 | AI1 signal type is voltage signal |
| P03.41 | AI1 low-end voltage (current) | 0.050 | 0.050V corresponds to 0Hz |
| P03.42 | AI1 high-end voltage (current) | 10.000 | 10.000V corresponds to 50Hz |
| P03.43 | AI1 low-end setting | 0.000 | AI1 low-end setting |
| P03.44 | AI1 high-end setting | 100.000 | AI1 high-end setting |
| P03.45 | AI2 signal type | 0 | AI2 signal type is voltage signal |
| P03.46 | AI2 low-end voltage (current) | 0.050 | 0.050V corresponds to 0Hz |
| P03.47 | AI2 high-end voltage (current) | 10.000 | 10.000V corresponds to 50Hz |
| P03.48 | AI2 low-end setting | 0.000 | AI2 low-end setting |
| P03.49 | AI2 high-end setting | 50.000 | AI2 high-end setting |
| P03.60 | AO1 signal type | 0 | AO1 signal type is voltage signal |
| P03.62 | AO1 low-end setting | 0.000 | AO1 low-end setting |
| P03.63 | AO1 high-end setting | 50.000 | AO1 high-end setting |
| P03.64 | AO1 low-end voltage (current) | 0.000 | 0.000V corresponds to 0Hz |
| P03.65 | AO1 high-end voltage (current) | 10.000 | 10.000V corresponds to 50Hz |
| P03.66 | AO2 signal type | 0 | AO2 signal type is voltage signal |
| P03.68 | AO2 low-end setting | 0.000 | AO2 low-end setting |
| P03.69 | AO2 high-end setting | 50.000 | AO2 high-end setting |
| P03.70 | AO2 low-end voltage (current) | 0.000 | 0.000V corresponds to 0Hz |
| P03.71 | AO2 high-end voltage (current) | 10.000 | 10.000V corresponds to 50Hz |

| | | | |
|--------|--------------------------------------|----|---|
| P01.39 | Command mode | 1 | Multi-command source mode |
| P02.00 | Multi-speed source | 0 | Multi-speed selection without external terminals |
| P02.10 | Set value source 1 | 3 | Set value source 1 select AI2 |
| P02.11 | Set value source 2 | 1 | Set value source 2 select multi-speed |
| P02.12 | Set value source 3 | 2 | Set value source 3 select AI1 |
| P02.13 | Set channel 1 relationship selection | 2 | Set the channel 1 relationship selection to F1 + F2 |
| P02.14 | Set channel 2 relationship selection | 8 | Set the channel 2 relationship selection to PID |
| P03.00 | Start command source | 7 | Start command to select keyboard, communication, external terminal S1 |
| P03.04 | Stop command source | 8 | Stop command is selected as external terminal S2 |
| P03.03 | JOG command source | 16 | JOG command is selected as external terminal S3 |
| P03.30 | Y1 terminal source | 3 | Relay 1 comes from the current state is running |
| P03.32 | Y2 terminal source | 4 | Relay 2 comes from current state fault |
| P03.34 | Y3 terminal source | 5 | Relay 3 comes from the current state alarm |

Comprehensive Macro 4

Comprehensive Macro 4

8.5 1-line command macro

1-line command macro (P01.20=20)

S1 controls start and stop.

- The command source include "start, stop and free stop".
- Use external terminal S1.

| Parameter No. | Function | Setting value | Note |
|---------------|--------------------------|---------------|--|
| P02.91 | Communication commands | 0 | 0 is no command; 1 is start command; 32 is free stop |
| P01.39 | Command mode | 1 | Multi-command source mode |
| P03.00 | Start command source | 7 | Start command selection is keyboard, communication, external terminal S1 |
| P03.04 | Stop command source | 0 | No effect |
| P03.05 | Free stop command source | 2 | Free stop command selection is communication |

8.6 2-line command macro 1

2-line command macro 1(P01.20=21)

S1 controls forward, S2 controls reverse.

- The command sources include "start stop, reverse start and free stop".
- Use external terminals S1 ~ S2.

| Parameter No. | Function | Setting value | Note |
|---------------|------------------------------|---------------|--|
| P01.39 | Command mode | 1 | Multi-command source mode |
| P03.00 | Start command source | 7 | Start command selection is keyboard, communication, external terminal S1 |
| P03.01 | Reverse start command source | 8 | Reverse start command selection is external terminal S2 |
| P03.04 | Stop command source | 0 | No effect |
| P03.05 | Free stop command source | 2 | Free stop command selection is communication |

8.7 2-line command macro 2

2-line command macro 2 (P01.20=22)

S1 controls start and stop, S2 controls direction.

- The command sources include "start stop, forward reverse and free stop".
- Use external terminals S1 ~ S2.

| Parameter No. | Function | Setting value | Note |
|---------------|--------------------------|---------------|--|
| P01.39 | Command mode | 1 | Multi-command source mode |
| P03.00 | Start command source | 7 | Start command selection is keyboard, communication, external terminal S1 |
| P03.02 | Reverse command source | 8 | Reverse command selection is external terminal S2 |
| P03.04 | Stop command source | 0 | No effect |
| P03.05 | Free stop command source | 2 | Free stop command selection is communication |

8.8 3-line command macro 1

3-line command macro 1 (P01.20=23)

Three-wire system.

- The command sources include "start, reverse start, stop, free stop".
- Use external terminals S1 ~ S3.

| Parameter No. | Function | Setting value | Note |
|---------------|------------------------------|---------------|--|
| P01.39 | Command mode | 1 | Multi-command source mode |
| P03.00 | Start command source | 7 | Start command selection is keyboard, communication, external terminal S1 |
| P03.01 | Reverse start command source | 8 | Reverse start command is selected as external terminal S2 |
| P03.04 | Source of stop command | 16 | Stop command is selected as terminal S3 |
| P03.05 | Free stop command source | 2 | Free stop command selection is communication |
| P03.20 | S1 type | 2 | Trigger on rising edge |
| P03.21 | S2 type | 2 | Trigger on rising edge |
| P03.22 | S3 type | 3 | Trigger on falling edge |

External control terminal command macro

External control terminal command macro

8.9 3-line command macro 2

3-line command macro 2 (P01.20=24)

Three-wire system.

- The command sources include start, forward and reverse, stop and free stop.
- Use external terminals S1 ~ S3.

| Parameter No. | Function | Setting value | Note |
|---------------|------------------------------|---------------|--|
| P01.39 | Command mode | 1 | Multi-command source mode |
| P03.00 | Start command source | 7 | Start command selection is keyboard, communication, external terminal S1 |
| P03.02 | Reverse start command source | 8 | Reverse start command is selected as external terminal S2 |
| P03.04 | Stop command source | 16 | Stop command is selected as terminal S3 |
| P03.05 | Free stop command source | 2 | Free stop command selection is communication |
| P03.20 | S1 type | 2 | Trigger on rising edge |
| P03.22 | S3 type | 3 | Trigger on falling edge |

External control terminal command macro

8.10 Main and auxiliary settings

Main and auxiliary settings (P01.20=30)

Various setting values are added and given.

- The set frequency is given by the main frequency A11 + auxiliary frequency (multi-stage speed + communication).
- No command source is given.
- No external terminals are used.

| Parameter No. | Function | Setting value | Note |
|---------------|--------------------------------------|---------------|---|
| P02.30 | Multi-speed 0 | 20 | Auxiliary frequency multi-speed 0 is set to 10Hz |
| P03.40 | AI1 signal type | 0 | AI1 signal type is voltage signal |
| P03.41 | AI1 low-end voltage (current) | 0.050 | 0.050V corresponds to 0Hz |
| P03.42 | AI1 high-end voltage (current) | 10.000 | 10.000V corresponds to 50Hz |
| P03.43 | AI1 low-end setting | 0.000 | AI1 low-end setting |
| P03.44 | AI1 high-end setting | 100.000 | AI1 high-end setting |
| P02.10 | Set value source 1 | 2 | Set value source 1 is AI1 |
| P02.11 | Set value source 2 | 1 | Set value source 2 is multi-speed |
| P02.12 | Set value source 3 | 5 | Set value source 3 is communication |
| P02.13 | Set channel 1 relationship selection | 2 | Set the channel 1 relationship selection to F1 + F2 |
| P02.14 | Set channel 2 relationship selection | 2 | Set the channel 2 relationship selection to F1 + F2 |
| P02.00 | Multi-speed source | 0 | Multi-speed selection without external terminals |

Main and auxiliary setting macro

8.11 Multi-stage speed macro

Multi-stage speed macro (P01.20=31)

Externally controlled four-speed.

- The set frequency is given by multi-step speed.
- Use external terminals S4 ~ S5.

| Parameter No. | Function | Setting value | Note |
|---------------|--------------------------------------|---------------|---|
| P02.30 | Multi-speed 0 | 20 | Multi-speed 0 is set to 10Hz |
| P02.31 | Multi-speed 1 | 30 | Multi-speed 1 is set to 15Hz |
| P02.32 | Multi-speed 2 | 40 | Multi-speed 2 is set to 20Hz |
| P02.33 | Multi-speed 3 | 50 | Multi-speed 3 is set to 25Hz |
| P02.10 | Set value source 1 | 1 | Set value source 1 is multi-speed |
| P02.13 | Set channel 1 relationship selection | 1 | Set the channel 1 relationship selection to F2 |
| P02.00 | Multi-speed source | 11000 | Multi-speed selection for external terminals are S4, S5 |

Multi speed macro

8.12 PID Macro 1

PID Macro 1 (P01.20=32)

PID.

- PID setting value: Multi-stage speed.
- PID feedback: AI1.

Multi-speed 0 — Set value
AI1 — Feedback value — PID — PID Output

| Parameter No. | Function | Setting value | Note |
|---------------|--------------------------------------|---------------|--|
| P02.30 | Multi-speed 0 | 20 | PID setting value |
| P03.40 | AI1 signal type | 0 | AI1 signal type is voltage signal |
| P03.41 | AI1 low-end voltage (current) | 0.050 | PID feedback signal lower limit |
| P03.42 | AI1 high-end voltage (current) | 10.000 | PID feedback signal upper limit |
| P03.43 | AI1 low-end setting | 0.000 | PID feedback value lower limit |
| P03.44 | AI1 high-end setting | 100.000 | PID feedback value upper limit |
| P02.10 | Set value source 1 | 1 | Set value source 1 is multi-speed |
| P02.11 | Set value source 2 | 2 | Set value source 2 is AI1 |
| P02.13 | Set channel 1 relationship selection | 8 | Set channel 1 relationship is PID |
| P02.00 | Multi-speed source | 0 | Multi-speed selection without external terminals |

PID macro 1

8.13 PID Macro 2

PID Macro 2 (P01.20=33)

PID.

- PID setting value: AI2.
- PID feedback: AI1.

AI2 — Set value

AI1 — Feedback value

PID

— PID Output

P02.10
3: AI2 setting

Set value 1

→

P02.13
8: PID

→

Set frequency

P02.11
2: AI1 setting

Set value 2

→

PID

| Parameter No. | Function | Setting value | Note |
|---------------|--------------------------------------|---------------|--|
| P03.40 | AI1 signal type | 0 | AI1 signal type is voltage signal |
| P03.41 | AI1 low-end voltage (current) | 0.050 | PID feedback signal lower limit |
| P03.42 | AI1 high-end voltage (current) | 10.000 | PID feedback signal upper limit |
| P03.43 | AI1 low-end setting | 0.000 | PID feedback value lower limit |
| P03.44 | AI1 high-end setting | 100.000 | PID feedback value upper limit |
| P03.45 | AI2 signal type | 0 | AI2 signal type is voltage signal |
| P03.46 | AI2 low-end voltage (current) | 0.050 | PID setting signal lower limit |
| P03.47 | AI2 high-end voltage (current) | 10.000 | PID setting value lower limit |
| P03.48 | AI2 low-end setting | 0.000 | PID setting value lower limit |
| P03.49 | AI2 high-end setting | 100.000 | PID setting value upper limit |
| P02.10 | Set value source 1 | 3 | Set value source 1 to AI2 |
| P02.11 | Set value source 2 | 2 | Set value source 2 to AI1 |
| P02.13 | Set channel 1 relationship selection | 8 | Set channel 1 relationship to PID |
| P02.00 | Multi-speed source | 0 | Multi-speed selection without external terminals |

PID macro 2

Start stop mode macro

8.14 Speed Start Macro

Speed Start Macro (P01.20=50)

Speed start (frequency tracking start).

P05.10
1: Speed start

→

Start method
Start function [P05.10]

| Parameter No. | Function | Setting value | Note |
|---------------|----------------|---------------|-----------------------------------|
| P05.10 | Start function | 1 | Start function is the speed start |

8.15 DC injection macro

DC injection macro (P01.20=51)

DC injection starts.

P05.10
2: DC injection

→

Start method
Start function [P05.10]

| Parameter No. | Function | Setting value | Note |
|---------------|----------------|---------------|--------------------------------|
| P05.10 | Start function | 2 | Start function is DC injection |

8.16 Free parking macro

Free parking macro (P01.20=52)

Free parking.

P05.20
0: Free parking

→

Stop method
Stop function [P05.20]

| Parameter No. | Function | Setting value | Note |
|---------------|----------------|---------------|------------------------------------|
| P05.20 | Stop function | 0 | Stop function is free parking. |
| P05.21 | Stop frequency | 100.000 | Stop frequency is set to 100.000Hz |

8.17 DC brake macro

DC brake macro (P01.20=53)

DC braking stops.

P05.20
1: DC braking

→

Stop method
Stop function [P05.20]

| Parameter No. | Function | Setting value | Note |
|---------------|----------------|---------------|------------------------------|
| P05.20 | Stop function | 1 | Stop function is DC braking |
| P05.21 | Stop frequency | 3 | Stop frequency is set to 3Hz |

8.18 Emergency acceleration macro

Emergency acceleration macro (P01.20=54)

Start quickly.

| Parameter No. | Function | Setting value | Note |
|---------------|-----------------------------------|---------------|---|
| P02.50 | Acceleration time 0 | 1 | The acceleration time is set to 1s |
| P05.00 | Control mode | 1 | Select open loop vector 1 |
| P05.71 | Current upper limit | 160 | The current limit is set to 160% |
| P07.51 | Slip compensation filter constant | 150 | The slip compensation filter is set to 150% |

8.19 Emergency deceleration macro

Emergency deceleration macro (P01.20=55)

Stop quickly.

| Parameter No. | Function | Setting value | Note |
|---------------|--|---------------|--|
| P02.70 | Deceleration time 0 | 1 | The deceleration time is set to 1s |
| P05.26 | Magnetic flux brake activation frequency | 100 | The flux brake activation frequency is set to 100% |
| P05.28 | Flux braking time | 3 | The flux braking time is set to 3s |
| P05.71 | Current upper limit | 180 | The current upper limit is set to 180% |
| P05.30 | Brake resistance mode | 1 | Choose the maximum duty cycle |

8.20 Console switch macro

Console switch macro (P01.20=60)

When there is multi-speed signal, it is given by multi-speed, and when there is no multi-speed signal, it is given by keyboard.

- The setting frequency can be selected by multi-speed or keyboard.
- Use external terminals S4、S5.

| Parameter No. | Function | Setting value | Note |
|---------------|--------------------------------------|---------------|--|
| P02.92 | Keyboard set value | * | Keyboard potentiometer |
| P02.31 | Multi-speed 1 | 30 | Multi-speed 1 is set to 15HZ |
| P02.32 | Multi-speed 2 | 40 | Multi-speed 1 is set to 20Hz |
| P02.33 | Multi-speed 3 | 50 | Multi-speed 1 is set to 25Hz |
| P16.76 | Selector 1 parameter source | 292 | Selector 1 parameter source is keyboard setting value |
| P16.77 | Selector 1 setting | 0 | Selector 1 is set to 0 |
| P16.78 | Selector 1 destination parameter | 230 | Selector 1 destination parameter source is multi-speed 0 |
| P02.10 | Set value source 1 | 1 | Set value source 1 is multi-speed |
| P02.13 | Set channel 1 relationship selection | 0 | Set the channel relationship selection to F1 |
| P02.00 | Multi-speed source | 11000 | Multi-speed source is external terminal S4, S5 |

Rapid acceleration/ deceleration macro

Console switch macro

8.21 Frequency reach macro

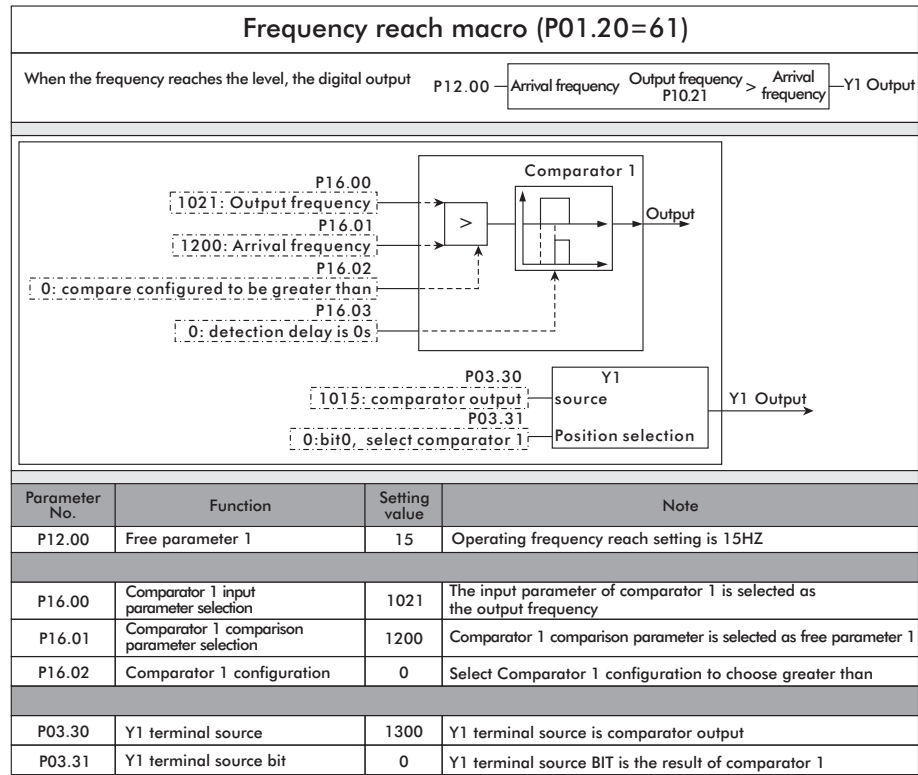

Frequency reach macro

8.22 FDT macro

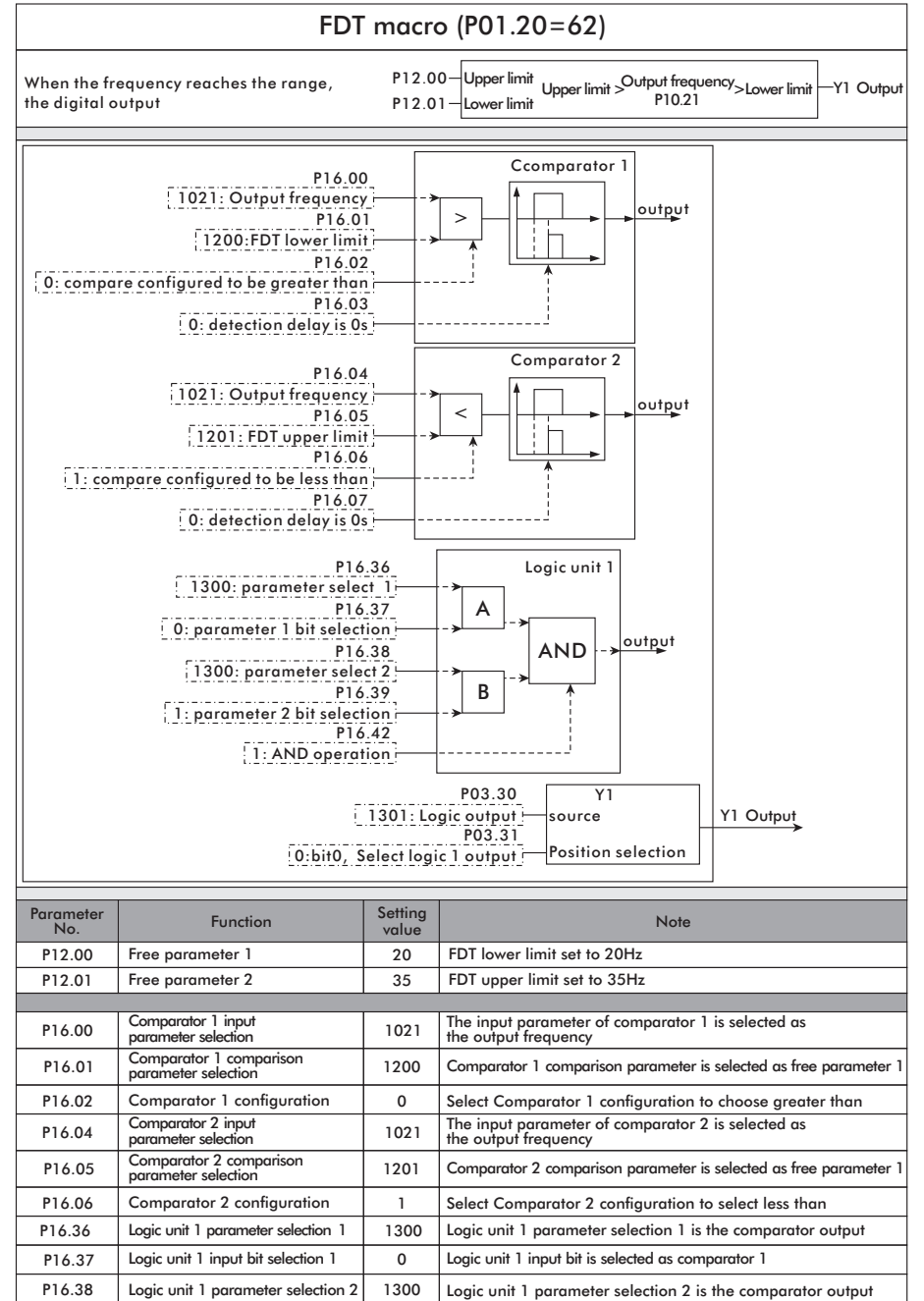

FDT macro

| | | | |
|--------|------------------------------------|------|--|
| P16.39 | Logic unit 1 input bit selection 2 | 1 | Logic unit 1 input bit selection 2 is comparator 2 |
| P16.42 | Logical unit 1 configuration 1 | 1 | Logical unit 1 is configured with AND |
| P03.30 | Y1 terminal source | 1301 | Y1 terminal source is logic output |
| P03.31 | Y1 terminal source bit | 0 | Y1 terminal source BIT bit is the result of logic unit 1 |

8.2.3 Acceleration and deceleration switching macro

Acceleration and deceleration switching macro (P01.20=63)

When the frequency reaches the level, the acceleration and deceleration are switched

P12.00—Acceleration time switching frequency point
 P12.02—P12.03—Acceleration time
 P12.01—Deceleration time switching frequency point
 P12.04—P12.05—Deceleration time

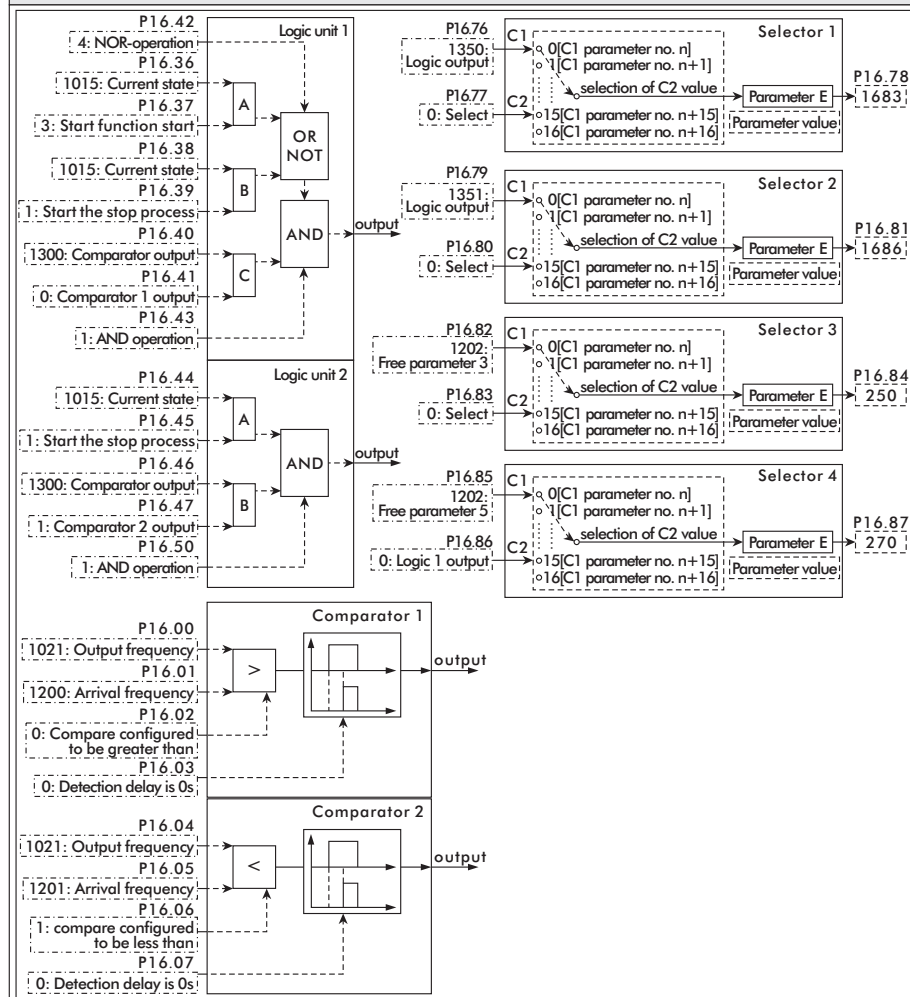

| Parameter No. | Function | Setting value | Note |
|---------------|---|---------------|---|
| P12.00 | Free parameter 1 | 15 | The switching frequency of acceleration time is set to 15Hz |
| P12.01 | Free parameter 2 | 10 | The switching frequency of deceleration time is set to 10Hz |
| P12.02 | Free parameter 3 | 5 | The default acceleration time is set to 5s |
| P12.03 | Free parameter 4 | 3 | Switch acceleration time is set to 3s |
| P12.04 | Free parameter 5 | 5 | The default deceleration time is set to 5s |
| P12.05 | Free parameter 6 | 8 | Switching deceleration time is set to 8s |
| P16.00 | Comparator 1 input parameter selection | 1021 | Output frequency |
| P16.01 | Comparator 1 comparison parameter selection | 1200 | Acceleration time switching frequency point |
| P16.02 | Comparator 1 configuration | 0 | Configuration selection is greater than |
| P16.04 | Comparator 2 input parameter selection | 1021 | Output frequency |
| P16.05 | Comparator 2 comparison parameter selection | 1201 | Deceleration time switching frequency point |
| P16.06 | Comparator 2 configuration | 1 | Configuration selection is less than |
| P16.36 | Logic unit 1 parameter selection 1 | 1015 | Current state |
| P16.37 | Logic unit 1 input bit selection 1 | 3 | Start function start |
| P16.38 | Logic unit 1 parameter selection 2 | 1015 | Current state |
| P16.39 | Logic unit 1 input bit selection 2 | 1 | Start the stop process |
| P16.40 | Logic unit 1 parameter selection 3 | 1300 | Comparator output |
| P16.41 | Logic unit 1 input bit selection 3 | 0 | Comparator 1 output |
| P16.42 | Logical unit 1 configuration 1 | 4 | Configuration 1 is NOR |
| P16.43 | Logical unit 1 configuration 2 | 1 | Configuration 2 is AND |
| P16.44 | Logic unit 2 parameter selection 1 | 1015 | Current state |
| P16.45 | Logic unit 2 input bit selection 1 | 1 | Start the stop process |
| P16.46 | Logic unit 2 parameter selection 2 | 1300 | Comparator output |
| P16.47 | Logic unit 2 input bit selection 2 | 1 | Comparator 2 output |
| P16.50 | Logical unit 2 configuration 1 | 1 | Configuration 1 is AND |
| P16.76 | Selector 1 parameter source | 1350 | Logic output 1 |
| P16.77 | Selector 1 setting | 0 | Logical choice |
| P16.78 | Selector 1 destination parameters | 1683 | Selector 3 setting |
| P16.79 | Selector 2 parameter source | 1351 | Logic output 2 |
| P16.80 | Selector 2 setting | 0 | Logical choice |
| P16.81 | Selector 2 destination parameters | 1686 | Selector 4 setting |
| P16.82 | Selector 3 parameter source | 1202 | Default acceleration time |
| P16.83 | Selector 3 setting | 0 | Acceleration time select |
| P16.84 | Selector 3 destination parameters | 250 | Acceleration time 0 |
| P16.85 | Selector 4 parameter source | 1204 | Default deceleration time |
| P16.86 | Selector 4 setting | 0 | Deceleration time select |
| P16.87 | Selector 4 destination parameters | 270 | Deceleration time 0 |

加減速切换宏

Acceleration and deceleration switching

8.24 Band-brake signal macro

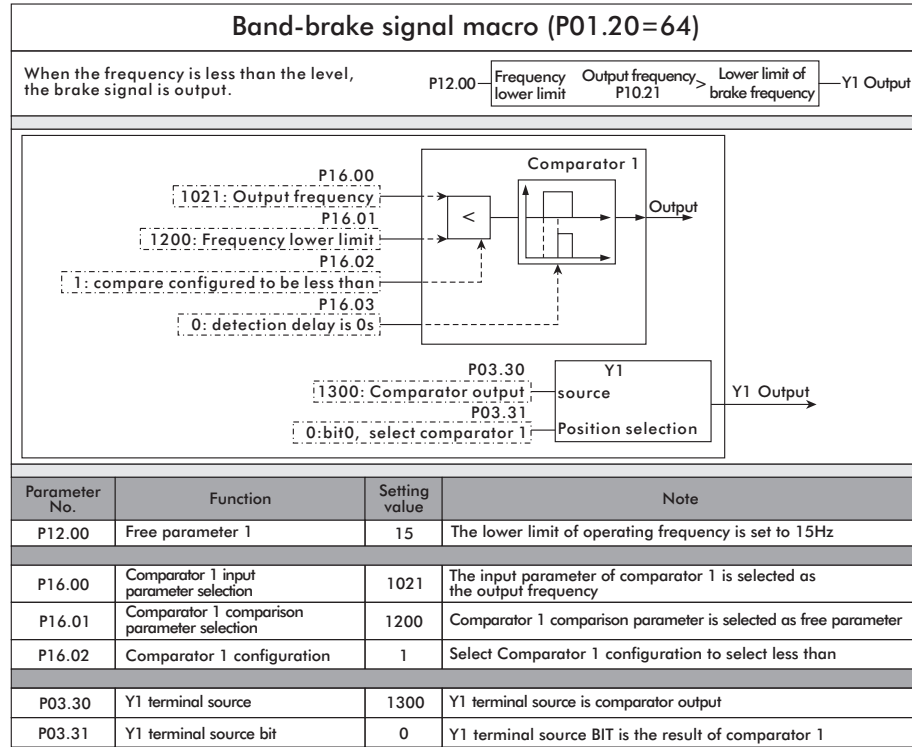

Brake signal macro

8.25 Release signal macro

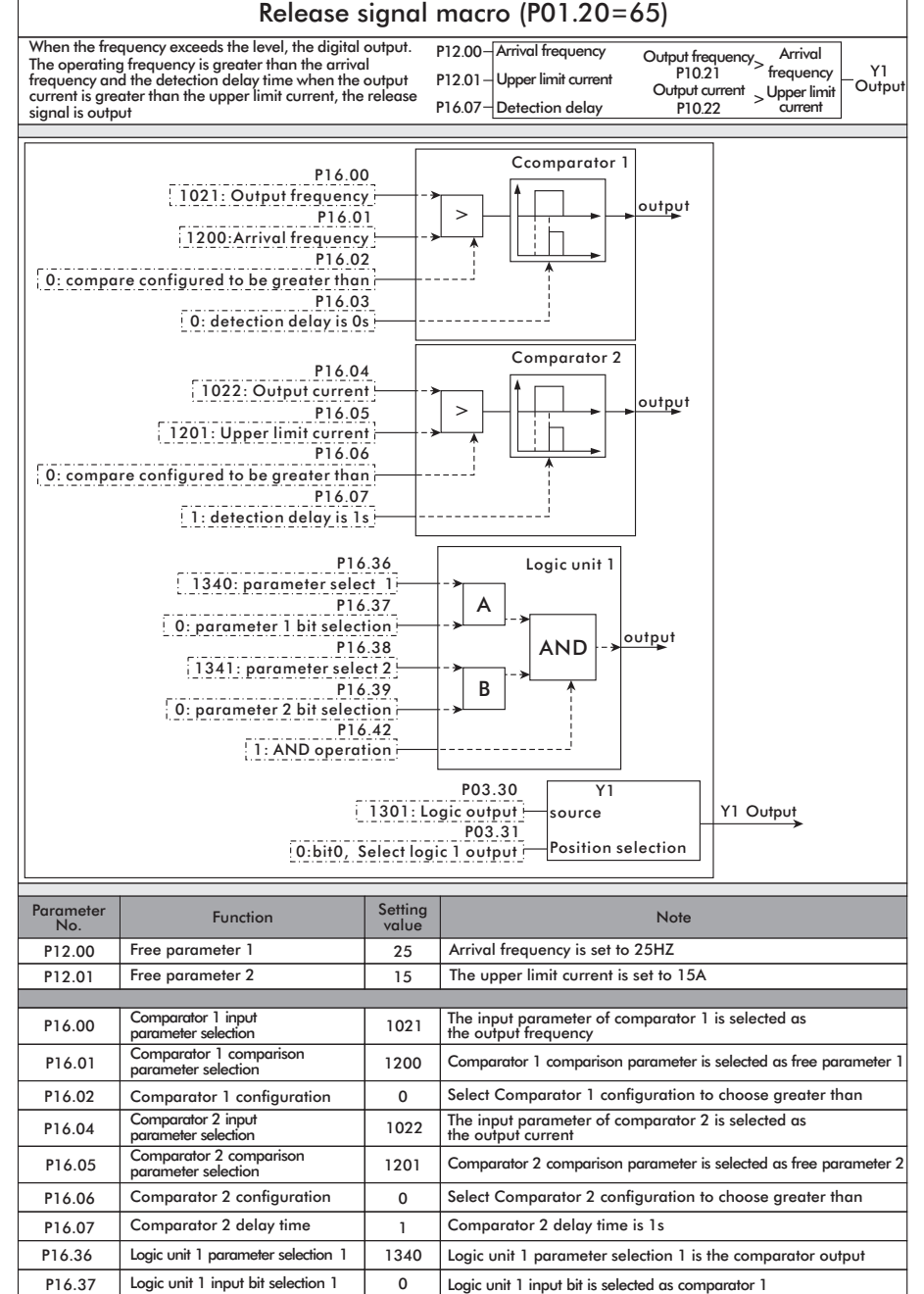

Release signal macro

| | | | |
|--------|------------------------------------|------|---|
| P16.38 | Logic unit 1 parameter selection 2 | 1341 | Logic unit 1 parameter selection 2 is the comparator output |
| P16.39 | Logic unit 1 input bit selection 2 | 0 | Logic unit 1 input bit selection 2 is comparator 2 |
| P16.42 | Logical unit 1 configuration 1 | 1 | Logical unit 1 is configured with AND |
| <hr/> | | | |
| P03.30 | Y1 terminal source | 1301 | Y1 terminal source is logic output |
| P03.31 | Y1 terminal source bit | 0 | Y1 terminal source bit is the result of logic unit 1 |

8.26 Break detection macro

Break detection macro (P01.20=66)

Band break / dry pump detection, generating a fault signal. The operating frequency is greater than the arrival frequency and the detection delay time. When the output current is less than the lower limit current, the output is faulty.

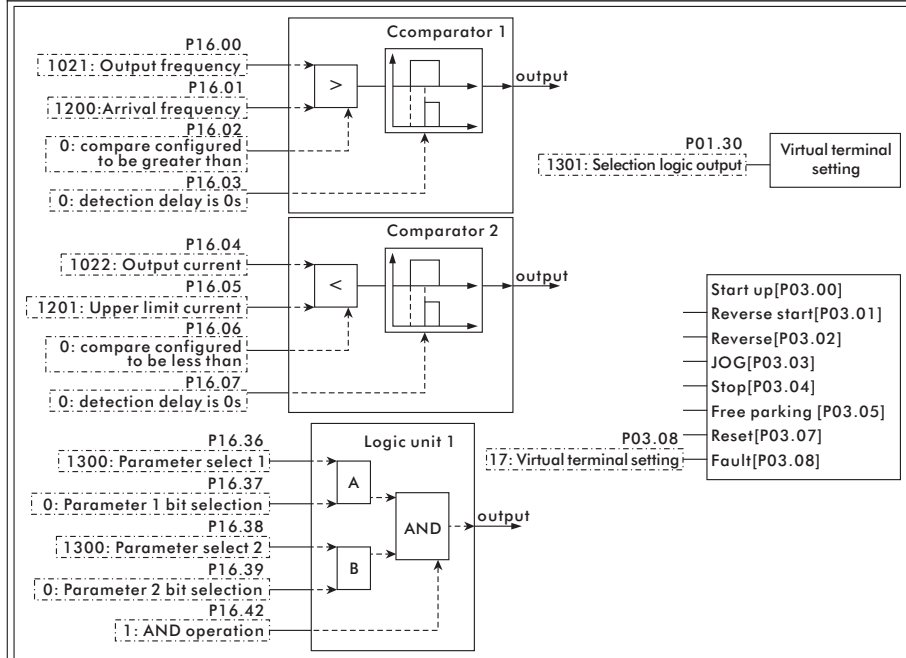
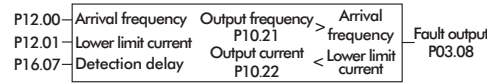

| Parameter No. | Function | Setting value | Note |
|---------------|---|---------------|---|
| P12.00 | Free parameter 1 | 25 | Arrival frequency is set to 25HZ |
| P12.01 | Free parameter 2 | 5 | The lower limit current is set to 5A |
| P16.00 | Comparator 1 input parameter selection | 1021 | The input parameter of comparator 1 is selected as the output frequency |
| P16.01 | Comparator 1 comparison parameter selection | 1200 | Comparator 1 comparison parameter is selected as free parameter 1 |
| P16.02 | Comparator 1 configuration | 0 | Select Comparator 1 configuration to choose greater than |
| P16.04 | Comparator 2 input parameter selection | 1022 | The input parameter of comparator 2 is selected as the output current |

| | | | |
|--------|---|--------|---|
| P16.05 | Comparator 2 comparison parameter selection | 1201 | Comparator 2 comparison parameter is selected as free parameter 1 |
| P16.06 | Comparator 2 configuration | 1 | Select Comparator 2 configuration to choose lessr than |
| P16.07 | Comparator 2 delay time | 10.000 | Comparator 2 delay time is 10.000s |
| P16.36 | Logic unit 1 parameter selection 1 | 1340 | Logic unit 1 parameter selection 1 is the comparator output |
| P16.37 | Logic unit 1 input bit selection 1 | 0 | Logic unit 1 input bit is selected as comparator 1 |
| P16.38 | Logic unit 1 parameter selection 2 | 1341 | Logic unit 1 parameter selection 2 is the comparator output |
| P16.39 | Logic unit 1 input bit selection 2 | 0 | Logic unit 1 input bit selection 2 is comparator 2 |
| P16.42 | Logic unit 1 configuration 1 | 1 | Logical unit 1 is configured with AND |
| <hr/> | | | |
| P01.30 | Virtual terminal setting | 1350 | Virtual terminal setting selection logic output 1 |
| P03.08 | Source of fault command | 17 | The fault command comes from the virtual terminal setting bit0 |

8.27 Signal loss macro

Signal loss macro (P01.20=67)

During the detection delay time, the detection signal is less than the threshold, and a fault signal is generated.

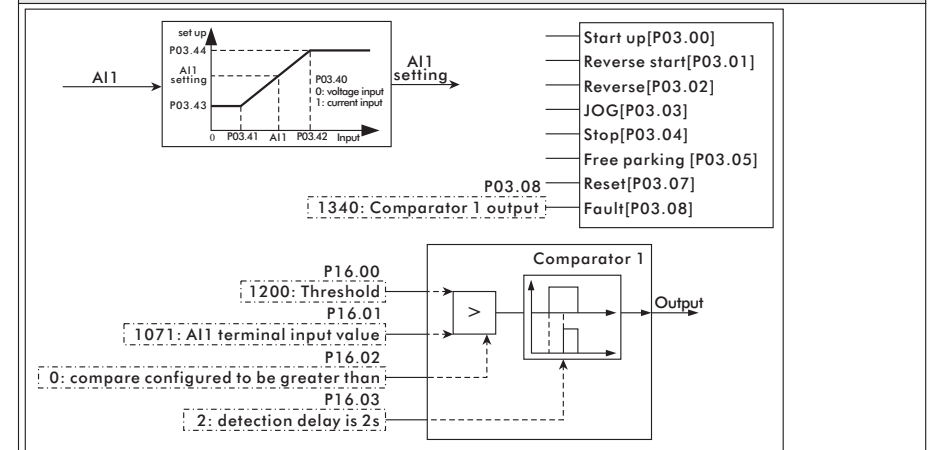

| Parameter No. | Function | Setting value | Note |
|---------------|---|---------------|--|
| P12.00 | Free parameter 1 | 1 | The threshold is set to 0.1V (10V corresponds to 100%) |
| P16.03 | Comparator 1 delay time | 2 | Comparator 1 delay time is 2s |
| P16.00 | Comparator 1 input parameter selection | 1200 | The input parameter of comparator 1 is selected as the lost voltage |
| P16.01 | Comparator 1 comparison parameter selection | 1071 | Comparator 1 comparison parameter is selected as input value of A11 terminal |
| P16.02 | Comparator 1 configuration | 0 | Select Comparator 1 configuration to choose greater than |
| P01.30 | Virtual terminal setting | 1340 | Logic unit 1 parameter selection 1 is the comparator output |
| P03.08 | Source of fault command | 17 | The fault command comes from the virtual terminal setting bit0 |

Break detection macro

Signal loss macro

8.2.8 Internal control eight-stage speed macro

Internal control eight-stage speed macro (P01.20=68)

- The internal control eight-stage timing switching speed.
- The external terminal uses S4 as the start signal.
- Cyclic execution.

S4 terminal — Internal control eight-stage speed enable
 P18.04~P18.11 — timing time
 P12.00~P12.08 — multi-stage speed

current number of segments

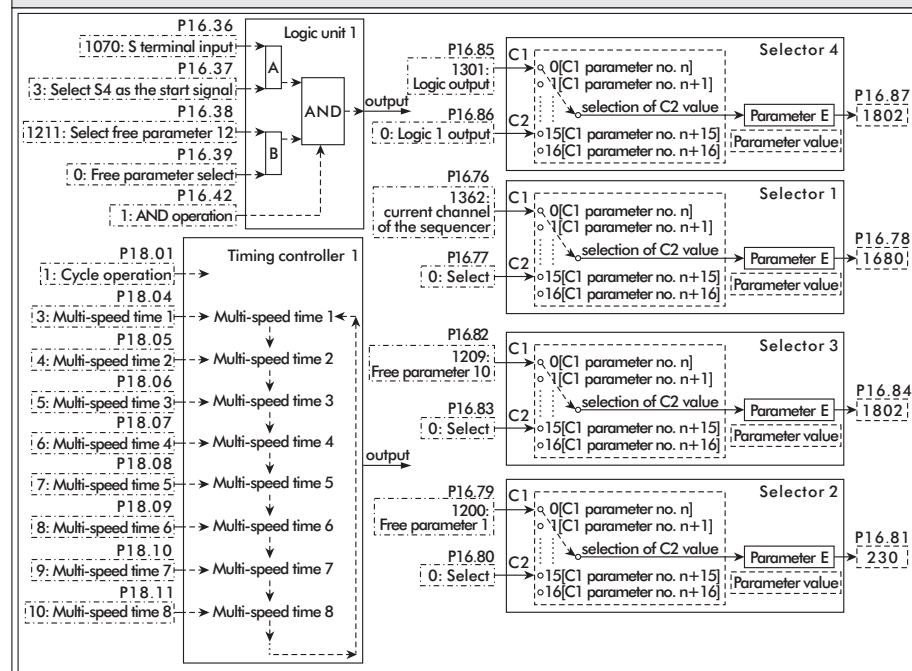

| Parameter No. | Function | Setting value | Note |
|---------------|----------------------|---------------|---------------------------------|
| P12.00 | Free parameter 1 | 0 | Stop frequency is set to 0Hz |
| P12.01 | Free parameter 2 | 10 | Multi-speed 1 is set to 5Hz |
| P12.02 | Free parameter 3 | 20 | Multi-speed 2 is set to 10Hz |
| P12.03 | Free parameter 4 | 30 | Multi-speed 3 is set to 15Hz |
| P12.04 | Free parameter 5 | 40 | Multi-speed 4 is set to 20Hz |
| P12.05 | Free parameter 6 | 50 | Multi-speed 5 is set to 25Hz |
| P12.06 | Free parameter 7 | 60 | Multi-speed 6 is set to 30Hz |
| P12.07 | Free parameter 8 | 70 | Multi-speed 7 is set to 35Hz |
| P12.08 | Free parameter 9 | 80 | Multi-speed 8 is set to 40Hz |
| P18.04 | Timer 1 phase 1 time | 3 | Multi-speed time 1 is set to 3s |
| P18.05 | Timer 1 phase 2 time | 4 | Multi-speed time 2 is set to 4s |
| P18.06 | Timer 1 phase 3 time | 5 | Multi-speed time 3 is set to 5s |
| P18.07 | Timer 1 phase 4 time | 6 | Multi-speed time 4 is set to 6s |
| P18.08 | Timer 1 phase 5 time | 7 | Multi-speed time 5 is set to 7s |

| | | | |
|--------|------------------------------------|----|---|
| P18.09 | Timer 1 phase 6 time | 8 | Multi-speed time 6 is set to 8s |
| P18.10 | Timer 1 phase 7 time | 9 | Multi-speed time 7 is set to 9s |
| P18.11 | Timer 1 phase 8 time | 10 | Multi-speed time 8 is set to 10s |
| P16.37 | Logic unit 1 input bit selection 1 | 3 | Select S4 as start signal, 0 as S1, 1 as S2 |

| | | | |
|--------|--------------------------------------|------|--|
| P18.01 | Timer 1 working mode | 1 | The working mode starts from multi-speed 1 to multi-speed 8 and runs cyclically. If it is set to 0, it will only run once. |
| P18.00 | Timer 1 clock source | 3 | Multi-speed time unit is S |
| P16.36 | Logic unit 1 parameter selection 1 | 1070 | S terminal input as cycle start signal |
| P16.38 | Logic unit 1 parameter selection 2 | 1211 | Select high level signal |
| P16.39 | Logic unit 1 input bit selection 2 | 0 | Select high level signal |
| P16.42 | Logical unit 1 configuration 1 | 1 | S terminal input high level signal is valid |
| P12.09 | Free parameter 10 | 5 | S terminal without input timing pause If set to 8: S terminal has no input, the current set frequency = stop frequency If set to 9: S terminal has no input, the current set frequency = multi-speed 1 |
| P12.10 | Free parameter 11 | 3 | S terminal has input timing start |
| P12.11 | Free parameter 12 | 1 | High level signal |
| P16.82 | Selector 3 parameter source | 1209 | Selector 3 parameter source is free parameter 10 |
| P16.83 | Selector 3 setting | 0 | Selector 3 is set to 0 |
| P16.84 | Selector 3 destination parameters | 1802 | The destination parameter of selector 3 is the timing controller 1 control command |
| P16.85 | Selector 4 parameter source | 1350 | Selector 4 parameter source is logic output 1 |
| P16.86 | Selector 4 setting | 0 | Selector 4 is set to 0 |
| P16.87 | Selector 4 destination parameters | 1683 | The purpose parameter of selector 4 is set by selector 3. |
| P16.76 | Selector 1 parameter source | 1362 | The parameter source of selector 1 is the current channel of timing controller 1. |
| P16.77 | Selector 1 setting | 0 | Selector 1 is set to 0 |
| P16.78 | Selector 1 destination parameters | 1680 | The purpose parameter of selector 1 is set by selector 2 |
| P16.79 | Selector 2 parameter source | 1200 | Selector 2 parameter source is free parameter 1 |
| P16.80 | Selector 2 setting | 0 | Selector 2 is set to 0 |
| P16.81 | Selector 2 destination parameters | 230 | The destination parameter of selector 2 is multi-speed 0 |
| P02.10 | Set value source 1 | 1 | Set value source 1 is multi-speed |
| P02.13 | Set channel 1 relationship selection | 0 | Set the channel 1 relationship selection to F1 |
| P16.88 | Selector 5 parameter source | 1360 | Timer count |
| P16.89 | Selector 5 setting | 0 | Selector 5 is set to 0 |
| P16.90 | Selector 5 destination parameters | 1290 | Save timer count when power off |
| P12.95 | Free parameter 96 | 1803 | Eight-speed memory, the value of P12.90 at power-on is given to the parameter number set in P12.95 |

| | | | |
|--------|--------------------------------|---|----------------------------------|
| P16.43 | Logical unit 1 configuration 2 | 0 | No effect |
| P18.03 | Timer 1 set value | 0 | No multi-speed jump |
| P18.12 | Timer 1 phase 9 time | 0 | Multi-speed time 9 is set to 0s |
| P18.13 | Timer 1 phase 10 time | 0 | Multi-speed time 10 is set to 0s |
| P18.14 | Timer 1 phase 11 time | 0 | Multi-speed time 11 is set to 0s |
| P18.15 | Timer 1 phase 12 time | 0 | Multi-speed time 12 is set to 0s |
| P18.16 | Timer 1 phase 13 time | 0 | Multi-speed time 13 is set to 0s |
| P18.17 | Timer 1 phase 14 time | 0 | Multi-speed time 14 is set to 0s |
| P18.18 | Timer 1 phase 15 time | 0 | Multi-speed time 15 is set to 0s |
| P18.19 | Timer 1 phase 16 time | 0 | Multi-speed time 16 is set to 0s |

Internal control eight-stage speed macro

Internal control eight-stage speed macro

CHAPTER 9 - RS485 Communication

9.1 Introduction

The inverter can be controlled and monitored by PLC or host computer software via RS-485.

9.2 Specifications

Table 9-1

| Project | Instruction |
|-----------------------|---|
| Way of communication | RS485 |
| Transmission type | Single master and multiple slaves |
| Number of connections | Max. 31 |
| Transmission distance | Maximum 1200m (recommended within 700m) |

Table 9-2

| Project | Instruction |
|-----------------------|------------------------------------|
| Communication speed | 2400, 4800, 9600, 19200, 38400 bps |
| Control sequence | Asynchronous communication |
| Communication Systems | Half duplex |
| Stop bit length | 0, 1, 1.5, 2 bit |
| Data bit | 7, 8 bit |
| Parity check | No check, even check, odd check |

9.3 Communication protocol

The complete Modbus query message includes: device address, function code, sent data, and error detection field. At the same time, the message returned by the device also includes the device address, function code, any data that needs to be returned, and the error detection field. If an error occurs during message reception, or the slave device cannot execute its command, the slave device will create an error message and send a response.

9.3.1 Format description

Table 9-3 Communication format

| Address | Function code | Data code | CRC check |
|---------|---------------|-----------|-----------|
| 8bits | 8bits | N*8bits | 16bits |

- 1) Address: 1-247 (namely the address of the slave connected to a PC);
- 2) Function code: supported functions (see Table 9-4);
- 3) Data code: data content $N \times 8$ bits;
- 4) CRC check: CRC check value;

Table 9-3 Functional coding

| Function code | Instruction |
|---------------|---|
| 0x03 | Read holding register |
| 0x06 | Preset single register (16-bit mode) |
| 0x10 | Preset multiple registers (32-bit mode) |

9.3.2 Address coding

In order to be compatible with different host computers, 16-bit and 32-bit access methods can be used for the same parameter. The corresponding addresses are shown in the table below. When using the 16-bit method, please note that the parameter value must be within the 16-bit expression range.

Table 9-4 Function coding rules

| Parameter value | Address | RAM Address |
|-----------------|---------------------------|-----------------------------------|
| 16 bit | Parameter No. - 1 | Parameter No. - 1 + 32768 |
| 32 bit | Parameter No. - 1 + 16384 | Parameter No. - 1 + 16384 + 32768 |

Note: When writing by address, the parameter value will be stored in the inverter EEPROM. Frequent storage of EEPROM will reduce the service life of EEPROM, so when there is no need to store, just change the value in RAM, then use the RAM address to write the parameters.

Table 9-6 Common Address Table

Communication setting value (write only), enable communication settings refer to the parameters P02.10~P02.14

| Function | Parameter No. | 16 bit method | 32 bit method | Remark |
|-----------------------------|---------------|---------------|---------------|---|
| Communication setting value | P02.90 | 8121H | C121H | P01.47=0, the upper computer 0~100000 corresponds to 0~maximum setting value P02.18; P01.47=1, the upper computer 0~10000 corresponds to 0~maximum setting value P02.18; P01.47=2, The upper computer 0~1000 corresponds to 0~maximum setting value P02.18; P01.47=3, the upper computer 0~100 corresponds to 0~maximum setting value P02.18 |

Control commands (write only), see the parameters P03.00 ~ P03.09 to enable the corresponding communication commands

| Function | Parameter No. | 16 bit method | 32 bit method | Command word (bit) | Definition |
|------------------------|---------------|---------------|---------------|--------------------|-------------------------|
| Communication commands | P02.91 | 8122H | C122H | 0 | Start up |
| | | | | 1 | Reverse |
| | | | | 2 | Start reverse |
| | | | | 3 | JOG |
| | | | | 4 | Stop |
| | | | | 5 | Emergency stop |
| | | | | 6 | Safe stop |
| | | | | 7 | Reset |
| | | | | 9 | Parameter self-learning |
| | | | | 11 | Pause |
| | | | | 13 | UP (incremental) |
| | | | | 14 | DOWN (decreasing) |

Inverter status (read only)

| Function | Parameter No. | 16 bit method | 32 bit method | Status word (bit) | Definition |
|---------------|---------------|---------------|---------------|-------------------|-------------------------------|
| Current state | P10.15 | 03F6H | 43F6H | 0 | Powering off |
| | | | | 1 | Stopping |
| | | | | 2 | Running |
| | | | | 3 | Start function start |
| | | | | 4 | Parameter self-learning start |
| | | | | 5 | Operating |
| | | | | 6 | Ready |
| | | | | 10 | Fault |
| | | | | 11 | Alarm |
| | | | | 12 | STO status |

Inverter failure (read only)

| Function | Parameter No. | 16 bit method | 32 bit method | Fault word (bit) | Definition |
|-------------|---------------|---------------|---------------|------------------|------------------------------|
| Fault state | P10.16 | 03F7H | 43F7H | 1 | System abnormality |
| | | | | 4 | Ground fault |
| | | | | 5 | Short circuit to ground |
| | | | | 6 | Output short circuit |
| | | | | 7 | Output overcurrent |
| | | | | 8 | DC bus overvoltage |
| | | | | 9 | DC bus undervoltage |
| | | | | 10 | Inverter overheating |
| | | | | 13 | Rectifier bridge overheating |
| | | | | 14 | U phase missing phase |

| Function | Parameter No. | 16 bit method | 32 bit method | Fault word (bit) | Definition |
|----------|---------------|---------------|---------------|------------------|-----------------------|
| | | | | 15 | V phase missing phase |
| | | | | 16 | W phase missing phase |
| | | | | 19 | No motor connection |
| | | | | 20 | Input phase loss |
| | | | | 21 | Inverter overload |
| | | | | 22 | Overtorque |
| | | | | 24 | Motor overheating |
| | | | | 25 | Motor overload |
| | | | | 26 | Current limit |
| | | | | 27 | Input power down |

Inverter function (read only)

| Function | Parameter No. | 16 bit method | 32 bit method | Data range | bit |
|---------------------------|---------------|---------------|---------------|----------------------|------|
| Output frequency | P10.21 | 03FCH | 43FCH | -65535.0~65535.0 | Hz |
| Output current | P10.22 | 03FDH | 43FDH | 0.00~65535.00 | A |
| Output voltage | P10.23 | 03FEH | 43FEH | 0.0~65535.0 | V |
| Output torque | P10.24 | 03FFH | 43FFH | 0.000~65535.000 | N·m |
| DC voltage | P10.25 | 0400H | 4400H | 0.0~65535.0 | V |
| Inverter temperature | P10.26 | 0401H | 4401H | 0~65535 | °C |
| Power | P10.30 | 0405H | 4405H | 0.000~65535.000 | kW |
| Energy consumption | P10.31 | 0406H | 4406H | 0.000~4294967.295 | kW·h |
| Hours of power on | P10.40 | 040FH | 440FH | 0.000~4294967.295 | h |
| Number of power-on | P10.41 | 041FH | 441FH | 0~4294967295 | |
| S terminal input status | P10.70 | 042DH | 442DH | 0~4294967295 | |
| A1 terminal input value | P10.71 | 042EH | 442EH | -65535.000~65535.000 | % |
| A12 terminal input value | P10.72 | 042FH | 442FH | -65535.000~65535.000 | % |
| Y terminal output status | P10.74 | 0431H | 4431H | 0~4294967295 | |
| AO1 terminal output value | P10.75 | 0432H | 4432H | -65535.000~65535.000 | % |
| AO1 terminal output value | P10.76 | 0433H | 4433H | -65535.000~65535.000 | % |

9.3.3 Read holding register

Read the data in the holding register, taking parameter P10.16 fault status and parameter P02.30 multi-stage speed 0 as an example.

➤ **Fault state (example)**

Read the value of inverter parameter P10.16, it can be known from the fault status table, just read 16 bits then the register address = 1016-1 = 1015 (03F7H).

Send data: 01 03 03 F7 00 01 35 BC

Receive data: 01 03 02 00 0A 38 43

P10.15 = 10 (000AH). The fault state is that the inverter is overheated. (See fault code)

Send data

| | |
|------------------|---------------------------------|
| Slave address | 01H |
| Function code | 03H |
| Register address | 04H(high byte) 24H(low byte) |
| Data | 00H(high byte) 01H(low byte) |
| CRC check | C5H(low byte) 31H(high byte) |

Receive data

| | |
|-------------------------------------|---------------------------------|
| Slave address | 01H |
| Function code | 03H |
| Number of data (Calculated in Byte) | 02H |
| Data | 00H(high byte) 0AH(low byte) |
| CRC check | 38H(low byte) 43H(high byte) |

➤ **Multi-speed 0 (example)**

Read the value of inverter parameter P02.30, when accessed with 32 bits, the register address = 230-1 + 16384 = 16613 (40E5H).

Send data: 01 03 40 E5 00 02 C0 3C

Receive data : 01 03 04 00 00 88 B8 9C 41

Reading data is 35000(88B8H), it can be seen that P02.30 = 35.000

Send data

| | |
|------------------|---------------------------------|
| Slave address | 01H |
| Function code | 03H |
| Register address | 40H(high byte) E5H(low byte) |
| Data | 00H(high byte) 02H(low byte) |
| CRC check | C0H(low byte) 3CH(high byte) |

Receive data

| | |
|-------------------------------------|---------------------------------|
| Slave address | 01H |
| Function code | 03H |
| Number of data (Calculated in Byte) | 04H |
| Data (high byte) | 00H(high byte) 00H(low byte) |
| Data (low byte) | 88H(high byte) B8H(low byte) |
| CRC check | 9CH(low byte) 41H(high byte) |

9.3.4 Preset a single register

Write the value of inverter parameter P05.00, when accessed with 16 bits, the register address = 500-1 = 499 (01F3H).

Send data: 01 06 01 F3 00 01 B9 C5

Receive data: 01 06 01 F3 00 01 B9 C5

Send data

| | |
|------------------|---------------------------------|
| Slave address | 01H |
| Function code | 06H |
| Register address | 01H(high byte) F3H(low byte) |
| Data | 00H(high byte) 01H(low byte) |
| CRC check | B9H(low byte) C5H(high byte) |

Receive data

| | |
|------------------|---------------------------------|
| Slave address | 01H |
| Function code | 06H |
| Register address | 01H(high byte) F3H(low byte) |
| Data | 00H(high byte) 01H(low byte) |
| CRC check | B9H(low byte) C5H(high byte) |

9.3.5 Preset multiple registers

Write the value of parameter P02.91, when accessed with 32 bits, the register address = 291-1 + 16384 = 16674 (4122H)

Table 9-7 Command control word table

| Command word(bit) | Definition |
|-------------------|-------------------------|
| 0 | Start |
| 1 | Reverse |
| 2 | Start reverse |
| 3 | JOG |
| 4 | Stop |
| 5 | Emergency stop |
| 6 | Safe stop |
| 7 | Reset |
| 9 | Parameter self-learning |
| 10 | Tripping |
| 11 | Pause |
| 13 | UP (incremental) |
| 14 | DOWN (decreasing) |

Taking the stop control word as an example, the value of parameter P02.91 is set to 16
 Send data : 01 10 41 22 00 02 04 00 00 00 10 4D F1
 Receive data : 01 10 41 22 00 02 F5 FE(16 hexadecimal)

Send data

| | |
|-------------------------------------|----------------|
| Slave address | 01H |
| Function code | 10H |
| Register address | 41H(high byte) |
| | 22H(low byte) |
| Number of registers (16 bits) | 00H(high byte) |
| | 02H(low byte) |
| Number of data (Calculated in Byte) | 04H |
| Data (high byte) | 00H(high byte) |
| | 00H(low byte) |
| Data (low byte) | 00H(high byte) |
| | 10H(low byte) |
| CRC check | 4DH(low byte) |
| | F1H(high byte) |

Receive data

| | |
|-------------------------------|----------------|
| Slave address | 01H |
| Function code | 10H |
| Register address | 41H(high byte) |
| | 22H(low byte) |
| Number of registers (16 bits) | 00H(high byte) |
| | 02H(low byte) |
| CRC check | F5H(low byte) |
| | FEH(high byte) |

9.3.6 Communication error codes

The inverter returns data when a communication error occurs. The format is shown in Table 9-8. Communication error function code = request function code + 128.

Table 9-8 Communication error data format

| Address | Function code | Fault code | CRC check |
|---------|---------------|------------|-----------|
| 8bits | 8bits | 8bits | 16bits |

Table 9-9 Error function code description

| Fault code | Instruction |
|------------|--|
| 0x00 | Parameter not exist |
| 0x01 | Cannot write defined parameters |
| 0x02 | The value of the parameter exceeds the upper limit of the parameter |
| 0x07 | Unchangeable |
| 0x0B | Not allowed to write |
| 0x11 | The data of the defined parameters cannot be changed in the current mode of the inverter |
| 0x12 | Other errors |
| 0x40 | Invalid data address |
| 0x41 | Invalid length |
| 0x42 | Invalid data length and value |
| 0x43 | Invalid parameter |
| 0x82 | No bus connection for defined parameters |
| 0x83 | The factory set value has been selected data and cannot be changed |

Note: the inverter communicates with the host computer, and it is recommended that the host computer set the timeout during 200ms~1000ms.

CHAPTER 10 - Fault exclusion and repair

10.1 Protection function



Alarm

The inverter must be rectified before the fault is reset, otherwise it may result in reduced product life and damage to other equipment.

10.2 Fault code table

| Fault code | Protection function | Explanation |
|------------|------------------------------|--|
| E0001 | System abnormality | Inverter hardware failure or software failure |
| E0004 | Ground fault | The resistance value to the ground is abnormal and leakage occurs |
| E0005 | Short circuit to ground | Short circuit to ground. |
| E0006 | Output short circuit | When the output current of the inverter is greater than 250% of the rated current of the inverter, the inverter turns off the output. |
| E0007 | output overcurrent | When the output current of the inverter is greater than 200% of the rated current of the inverter, the inverter turns off the output. |
| E0008 | DC bus overvoltage | If the DC voltage of the main circuit is higher than 400V (220V model) or 800V (380V model) when the motor decelerates, the inverter shuts off the output. |
| E0009 | DC bus undervoltage | When the input voltage decreases, if the DC voltage of the main circuit is lower than 200V (220V model) or 340V(380V model), the inverter will turn off the output |
| E0010 | Inverter overheating | When the temperature of the heat sink is detected to be overheated, the inverter turns off the output. |
| E0011 | Self-learning failure | The self-learning parameters are incorrect or the motor is abnormal. |
| E0013 | Rectifier bridge overheating | The rectifier module is overheated |
| E0014 | U phase missing phase | U phase missing phase |
| E0015 | V phase missing phase | V phase missing phase |
| E0016 | W phase missing phase | W phase missing phase |
| E0019 | No motor connection | The motor is disconnected during operation. |
| E0020 | Input phase loss | Input power phase loss |
| E0021 | Inverter overload | When the output current of the inverter exceeds the rated rating of the inverter (150% for 1 minute), the inverter turns off the output. |
| E0022 | Overtorque | Motor over torque |
| E0024 | Motor overheating | The motor temperature is too high. |
| E0025 | Motor overload | When the output current of the inverter exceeds the rated rating of the motor (150% for 1 minute), the inverter turns off the output. |
| E0026 | Current limit | The output current exceeds the set limit threshold. |
| E0027 | Input power down | The input voltage is lower than the power-down level (P05.86). |
| E0033 | STO | STO safe torque stop |
| E0034 | STI1 | STI1 internal circuit abnormal |
| E0035 | STI2 | STI2 internal circuit abnormal |
| E0036 | STI3 | The internal circuit of STI1 and STI2 is abnormal. |
| E0063 | User failure | User-defined fault (see parameter P03.08) |

Note: The alarm code is also in accordance with the above table, for example, the keyboard display "A0025" represents the motor overload alarm.

10.3 Maintenance and inspection prevention



Alarm

Make sure to remove input power during maintenance. Make sure that the DC connection capacitor is discharged for maintenance, even if the bus capacitance of the inverter's main circuit is still charged after the power is turned off. Use the detector to check the voltage between P + and P- before proceeding. H1 series inverters have ESD (electrostatic discharge) sensitive components. During inspection or installation, take protective measures to avoid ESD before touching, do not change any internal parts and connections, and do not change the inverter.

10.4 Checkpoint

- Daily inspection
 - Appropriate installation environment
 - Cooling system failure
 - Uncommon shock and noise
 - Uncommon overheating and discoloration
- Periodic inspection
 - Screws and nuts may be loose due to vibration, temperature changes, etc.
 - Check that they are fastened and as tight as possible
 - Foreign objects in the cooling system
 - Use air to clean
 - Check the cooling fan rotation conditions, capacitor conditions and magnetic contactor connection
 - If not normal replacement

10.5 Parts replacement

The inverter consists of electronic components such as semiconductor devices. Due to structural or physical characteristics, the following components may age, causing the inverter to fail to operate. The components must be replaced periodically.

CHAPTER 11 - Technical Notes

| | Project | Project description |
|--------------------------|-------------------------------------|---|
| Output | Rated voltage;Frequency | Three phase:380~440V,50Hz/60Hz; Single phase:200V~240V,50Hz/60Hz |
| | Allowable voltage working range | Three phase:320V~460V; Single phase:180V~ 260V; Voltage imbalance rate:<3%;Frequency:±5% |
| Input | Voltage | 0~Rated input voltage |
| | Frequency | 0Hz~1000Hz |
| Main control performance | Overload capacity | 150% rated current for 1 minute, 180% rated current for 2 seconds |
| | Control mode | V/F, Speed sensorless vector control |
| | Modulation | Space vector PWM modulation |
| | Motor type | Asynchronous motor, synchronous motor, single-phase motor (please consult the manufacturer when using) |
| | Starting torque | 150% rated torque at 0.5Hz |
| | Speed range | 1:100(Without speed sensor) |
| | Frequency accuracy | Digital setting: maximum frequency±0.01%;Analog setting: maximum frequency±1% |
| | Frequency resolution | Digital setting: 0.01Hz; Analog setting: maximum frequency 1% |
| | Acceleration and deceleration curve | Straight line / S curve acceleration / deceleration |
| | Limiting | Automatically limit the current during operation to prevent frequent overcurrent fault tripping |
| Run function | Instantaneous power failure | Support instantaneous stop and automatic frequency reduction |
| | Command source | Keyboard given, terminal given, communication given |
| Operation keyboard | Source of settings | Digital setting, analog setting, multi-speed, communication setting |
| | PID | Support main given + PID |
| Environment | Nixie tube display | Display output frequency, output current, output voltage, bus voltage, display value 1, display value 2, current alarm, current fault |
| | External keyboard | support |
| | Protective function | Overcurrent protection, overvoltage protection, undervoltage protection, overheat protection, overload protection, phase loss protection, earth leakage, etc. |
| | Place of use | Indoor, no direct sunlight, no dust, corrosive gas, flammable gas, oil mist, water vapor, dripping water or salt etc. |
| | Altitude | For derating above 1000 meters, derate 10% for increase every 1000 meters |
| | Ambient temperature | -10℃ ~ + 40℃ (Ambient temperature is 40℃~50℃, please use derating) |
| | Humidity | 5% ~ 95% RH, no condensation |
| | Storage temperature | -40℃~+70℃ |
| Vibration | Less than 5.9 m / s 2 (0.6g) | |

CHAPTER 12 - Selection of braking resistor

12.1 Brake resistor configuration table

| Voltage level | Inverter power | Braking unit | | Braking resistor | | | Braking torque (10%UD) | |
|---------------|----------------|---------------|-----------------|-------------------------|-----------------|------|------------------------|---|
| | | Specification | Quantity(piece) | Power(w)/ Resistance(Ω) | Quantity(piece) | | | |
| 220V | 0.75kW | Built-in | | 80 | 120 | 1 | 100% | |
| | 1.5kW | | | 150 | 100 | 1 | | |
| | 2.2kW | | | 300 | 68 | 1 | | |
| | 3.7kW | | | 300 | 68 | 1 | | |
| | 5.5kW | | | 400 | 30 | 1 | | |
| | 7.5kW | | | 400 | 30 | 1 | | |
| | 0.75kW | | | 150 | 300 | 1 | | |
| | 1.5kW | | | 200 | 300 | 1 | | |
| | 2.2kW | | | 200 | 200 | 1 | | |
| | 4.0kW | | | 400 | 150 | 1 | | |
| 5.5kW | 400 | | | 100 | 1 | | | |
| 7.5kW | 750 | | | 75 | 1 | | | |
| 11kW | 1000 | | | 60 | 1 | | | |
| 15kW | 1500 | | | 40 | 1 | | | |
| 18.5kW | 2500 | | | 30 | 1 | | | |
| 22kW | 3000 | | | 30 | 1 | | | |
| 30kW | 5000 | | | 25 | 1 | | | |
| 37kW | 7500 | | | 20 | 1 | | | |
| 45kW | DBU-4045 | | | 1 | 10000 | 13.6 | | 1 |
| 55kW | DBU-4030 | | | 2 | 5000*2 | 25 | | 1 |
| 75kW | DBU-4045 | 2 | 7500*2 | 15 | 1 | | | |
| 90kW | | 2 | 10000*2 | 13.6 | 1 | | | |
| 110kW | DBU-4160 | 1 | 20000 | 8 | 1 | | | |
| 132kW | | 1 | 25000 | 6 | 1 | | | |
| 160kW | | 1 | 30000 | 6 | 1 | | | |

Note:

- Please select the power number and resistance value recommended by our company
- The power numbers and resistance value recommended in the above table are calculated according to 100% braking torque and 10% utilization rate. When the load demand and system reliability are met, the resistance power and resistance value can be appropriately increased or decreased; When it is required to increase the braking torque or use a higher power, the power and resistance value of the braking resistor should be changed appropriately, or consult our company.
- When installing the braking resistor, be sure to consider the safety and non-flammability of the surrounding environment.

- Braking frequency $UD = t1 / t2 * 100\%$
 t1: braking time within one working cycle
 t2: one duty cycle

The braking usage rate doubles and the power of the corresponding braking unit and braking resistor is doubled.

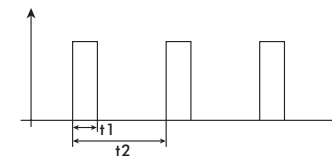

- In the above table, the resistance value and power greater than 2500W are the total resistance value and power, the power of the resistance based on 2500W as the base number, for example, if you need a 2500W 6Ω resistor, you need 10 250W 6Ω resistors in parallel. Calculation of braking resistor statistics show that when the braking current IB flowing through the energy-consuming circuit is equal to half of the rated current of the motor, the braking torque of the motor is approximately equal to its rated torque:

$$IB = IMN / 2 \quad TB \approx TMN \quad \text{or} \quad IB = 2UB / IMN$$

In the formula:

- IB—Braking current,A; IMN—Motor rated current,A;
- TB—Braking torque,N.m; TMN—Motor rated torque,N.m.

In general, the selection range of braking torque is

$$TMN < TB < 2TMN \quad \text{then:} \quad IMN < IB < 2IMN$$

The user can decide the braking current according to the specific situation of the production machinery.

After the braking current is determined, it is easy to calculate the braking resistance

$$RB = UB/IB \quad RB_{min} = UB/IMN$$

UB is the braking threshold voltage; RB is the resistance of the braking resistor, where UB is generally 1.1 times the rated bus voltage; Rbmin is the minimum value of the braking resistor

Common values of braking threshold voltage:

$$AC220V:DC380V \quad AC380V:DC680V \quad AC660V:DC1140V$$

Knowing IB and RB can determine the power of the resistor

$$\lambda : \text{Actual resistance value / calculated value first; } ED\% : \text{Braking utilization rate}$$

For example:

Suppose an existing 7.5KW motor has a rated current of 18A and a rated input voltage of 380V then there are: $RB = 680V/9A = 75\Omega$

$$RB_{min} = 680/18 = 38\Omega$$

75Ω according to experience

$$\text{Power of braking resistor} = 1 * 680^2 / 75 * 0.1 = 616W$$

In actual use, the power can be properly amplified.

12.2 Installation dimension drawing of braking resistor

| Rated power (w) | Size(mm) | | | | | | | | | |
|--------------------|----------|--------|--------|-------|-----|----|----|--------|----|-----|
| | L1(±2) | L2(±5) | L3(±3) | D(±2) | B | B1 | H | H1(±3) | N | φd |
| 80 | 152 | 174 | 196 | 28 | 6.5 | 28 | 28 | 61 | 10 | 4.5 |
| 150 | 195 | 217 | 239 | 40 | 8 | 40 | 41 | 81 | 12 | 5.5 |
| 200 | 195 | 217 | 239 | 40 | 8 | 40 | 41 | 81 | 12 | 5.5 |
| 300 | 282 | 304 | 326 | 40 | 8 | 40 | 41 | 81 | 12 | 5.5 |
| 400 | 282 | 304 | 326 | 40 | 8 | 40 | 41 | 81 | 12 | 5.5 |
| 750 | 316 | 338 | 360 | 50 | 8 | 50 | 45 | 101 | 16 | 6 |
| 1000 | 300 | 325 | 350 | 60 | 8.5 | 60 | 60 | 119 | 16 | 6 |
| 1500 | 415 | 440 | 465 | 60 | 8.5 | 60 | 60 | 119 | 16 | 6 |
| 2000 | 510 | 535 | 560 | 60 | 8.5 | 60 | 60 | 119 | 16 | 6 |
| 2500 | 600 | 625 | 650 | 60 | 8.5 | 60 | 60 | 119 | 16 | 6 |

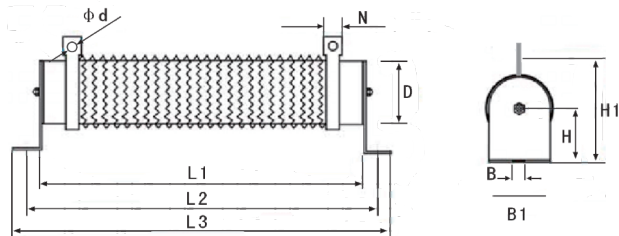

CHAPTER 13 - Dimensions

| Frame number | H1 Series structure size table | | | | | |
|--------------|--------------------------------|-----------|----------|------|-----|----|
| | Size(mm) | | | | | |
| | W(width) | H(height) | D(depth) | A | B | d |
| F1 | 85 | 170 | 124 | 67.3 | 158 | 5 |
| F2 | 97 | 194 | 133 | 85 | 184 | 5 |
| F3 | 126 | 237 | 147 | 112 | 223 | 5 |
| F4 | 168 | 298 | 160 | 154 | 283 | 6 |
| F5 | 198 | 355 | 177 | 183 | 338 | 6 |
| F6 | 250 | 400 | 208 | 230 | 380 | 7 |
| F7 | 280 | 545 | 292 | 200 | 526 | 9 |
| F8 | 380 | 648 | 299 | 300 | 626 | 11 |
| F9 | 450 | 798 | 318 | 340 | 773 | 11 |

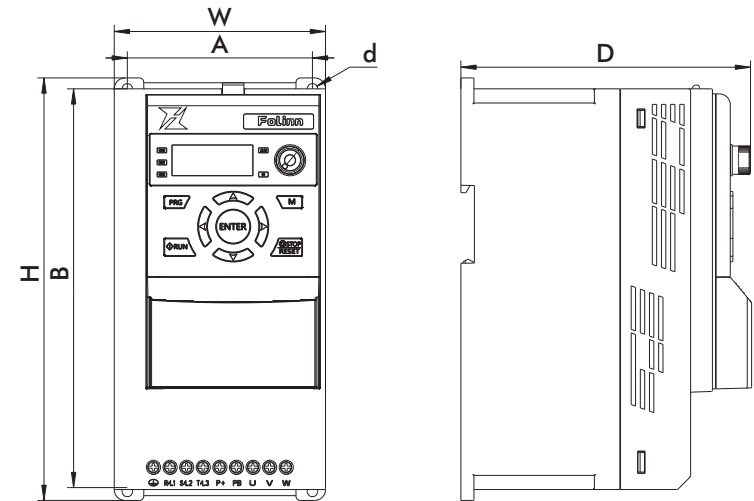

CHAPTER 14 - Quick parameter configuration table

| Quick parameters | Basic parameters | Function |
|------------------|------------------|------------------------------------|
| P00.09 | P01.11 | Parameter operation |
| P00.10 | P02.10 | Setting (frequency) source F1 |
| P00.11 | P02.11 | Setting (frequency) source F2 |
| P00.12 | P02.13 | Set relationship selection |
| P00.13 | P02.18 | Maximum setting |
| P00.14 | P05.08 | Motor output frequency upper limit |
| P00.15 | P02.00 | Multi-speed source |
| P00.16 | P02.30 | Multi-speed 0 |
| P00.17 | P02.31 | Multi-speed 1 |
| P00.18 | P02.32 | Multi-speed 2 |
| P00.19 | P02.33 | Multi-speed 3 |
| P00.20 | P02.34 | Multi-speed 4 |
| P00.21 | P02.35 | Multi-speed 5 |
| P00.22 | P02.36 | Multi-speed 6 |
| P00.23 | P02.37 | Multi-speed 7 |
| P00.24 | P02.50 | Acceleration time 0 |
| P00.25 | P02.70 | Deceleration time 0 |
| P00.26 | P02.24 | JOG frequency |
| P00.30 | P03.00 | Start command source |
| P00.31 | P03.01 | Reverse start command source |
| P00.32 | P03.02 | Reverse command source |
| P00.33 | P03.03 | JOG command source |
| P00.34 | P03.04 | Source of stop command |
| P00.35 | P03.05 | Free parking order source |
| P00.36 | P03.07 | Reset command source |
| P00.37 | P03.20 | S1 type |
| P00.38 | P03.21 | S2 type |
| P00.39 | P03.22 | S3 type |
| P00.40 | P03.30 | Y1 terminal source |
| P00.41 | P03.41 | All low-end voltage (current) |
| P00.42 | P03.42 | All high-end voltage (current) |
| P00.43 | P03.43 | All low-end settings |
| P00.44 | P03.44 | All high-end settings |
| P00.45 | P03.61 | AO1 signal source |
| P00.46 | P03.62 | AO1 low-end settings |
| P00.47 | P03.63 | AO1 high-end settings |
| P00.48 | P03.64 | AO1 low-end voltage (current) |
| P00.49 | P03.65 | AO1 high-end voltage (current) |
| P00.50 | P04.00 | PID proportional gain |
| P00.51 | P04.01 | PID integral gain |
| P00.52 | P04.05 | PID output upper limit |
| P00.53 | P04.06 | PID output lower limit |

| Quick parameters | Basic parameters | Function |
|------------------|------------------|------------------------|
| P00.53 | P04.06 | PID output lower limit |
| P00.54 | P04.09 | PID range |
| P00.55 | P04.11 | PID sleep frequency |
| P00.56 | P04.12 | PID enters sleep time |
| P00.57 | P04.13 | PID wakeup deviation |
| P00.58 | P04.14 | PID entry wake-up time |
| P00.59 | P04.15 | PID sleep action |
| P00.60 | P05.10 | Start function |
| P00.61 | P05.11 | Start Time |
| P00.62 | P05.12 | Start frequency |
| P00.63 | P05.19 | DC injection current |
| P00.64 | P05.20 | Stop function |
| P00.65 | P05.21 | Stop frequency |
| P00.66 | P05.22 | DC braking current |
| P00.67 | P05.23 | DC braking time |
| P00.68 | P05.30 | Brake resistance mode |
| P00.70 | P05.00 | Control method |
| P00.71 | P06.05 | Carrier frequency |
| P00.72 | P06.11 | Motor rated Power |
| P00.73 | P06.12 | Motor rated voltage |
| P00.74 | P06.13 | Motor rated frequency |
| P00.75 | P06.14 | Motor rated current |
| P00.76 | P06.15 | Motor rated speed |
| P00.78 | P07.71 | VF curve - F1 |
| P00.79 | P07.72 | VF curve - F2 |
| P00.80 | P07.73 | VF curve - F3 |
| P00.81 | P07.74 | VF curve - F4 |
| P00.82 | P07.75 | VF curve - V0 |
| P00.83 | P07.76 | VF curve - V1 |
| P00.84 | P07.77 | VF curve - V2 |
| P00.85 | P07.78 | VF curve - V3 |
| P00.86 | P07.79 | VF curve - V4 |

CHAPTER 15 - Standard card (H0101) instructions for use

15.1 Overview

The H10001 card is a multi-functional I / O standard card used for H1 series inverters. It can realize 4 digital inputs, 1 relay output and 1 analog input. It also has an RS-485 communication interface (integrated in Ethernet port), can be connected to the external keyboard.

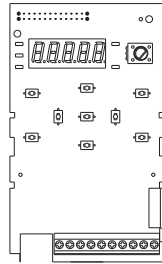

H0101 standard card Distribution diagram

15.2 Mechanical installation

Please install it when the inverter is completely powered off; align the pins(26 pins) on the H0101 card and the inverter power board plug tightly.

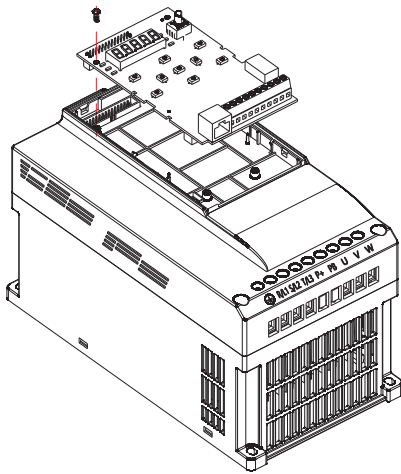

H0101 standard card Mechanical installation drawing

15.3 Wiring diagram

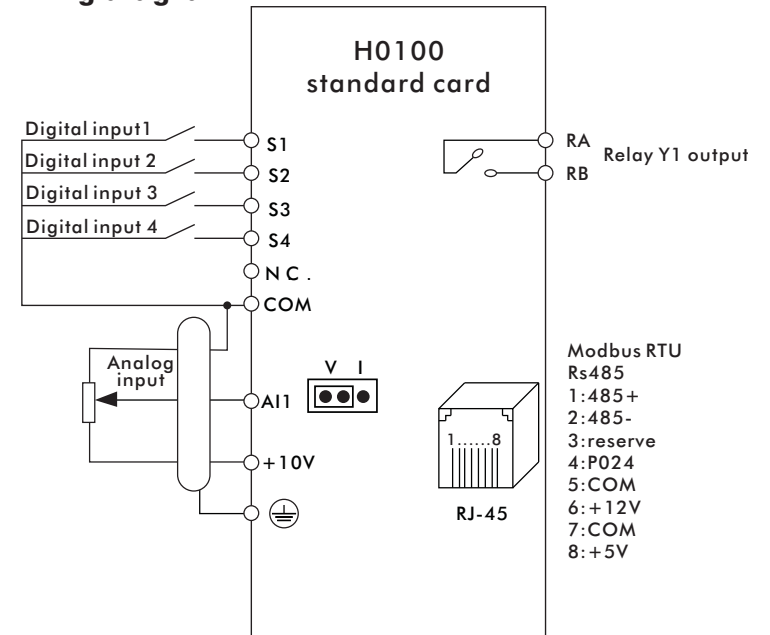

15.4 Control terminal

15.4.1 Terminal specifications

| Terminal symbol | Terminal name | Function Description |
|-----------------|------------------------|--|
| +10V | 10V power supply | Provide + 10V power to the outside, maximum output current 50mA |
| AI1 | Analog input terminal | 1. Input voltage range: DC 0V ~ 10V 2. Input current range: 0 ~ 20mA 3. Select voltage or current through AI1 jumper |
| COM | Digital, analog | Internally isolated from communication ground GND |
| S1~S4 | Digital input terminal | 1. Optocoupler isolation 2. Input impedance: 2.4kΩ 3. Voltage range during level input, 9V ~ 30V |
| N.C. | reserve | Reserved terminal |
| RA RB | Relay output | 1. Resistive load:250VAC 3A/30VDC 3A; 2. Inductive load:250VAC 0.2A/24VDC 0.1A(cos φ =0.4); |
| RJ45 | Network port | The keyboard can be externally connected or connected to the host computer |

15.4.2 Terminal wiring

A. Digital input terminal:

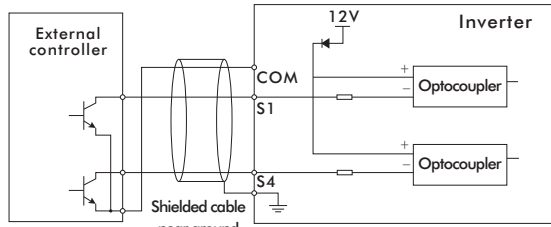

Digital input terminal wiring

Note: The wiring method of the digital input terminal of the standard configuration card is NPN type. If the user needs other wiring methods, please consult our technical staff.

B. Analog input terminal:

Because weak analog voltage signals are particularly susceptible to external interference, shielded cables are generally required, and the wiring distance should be as short as possible, not exceeding 20 meters. As shown below:

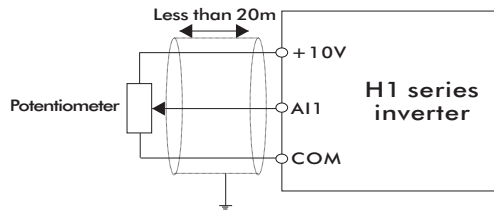

Schematic diagram of analog input terminal wiring

At some occasions where the analog signal is severely interfered, the analog signal source needs to add a filter capacitor or a ferrite core. As shown below:

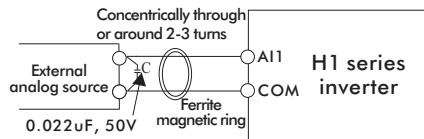

Analog input terminal plus filter processing wiring diagram

CHAPTER 16 - H0110 Card instructions for use

16.1 Overview

H0110 card is a multifunctional I/O card for H1 series inverter. It can realize 4 channels digital input, 2 channels of relay output, 1 channel of analog input and 2 channels of analog output, and also has RS-485 communication interface, can be connected to the external keyboard

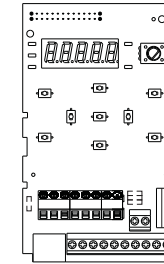

H0110 card Distribution diagram

16.2 Mechanical installation

Please install when the inverter is completely powered off; align the pins(26 pins) on the H0110 card and the inverter power board plug tightly. .

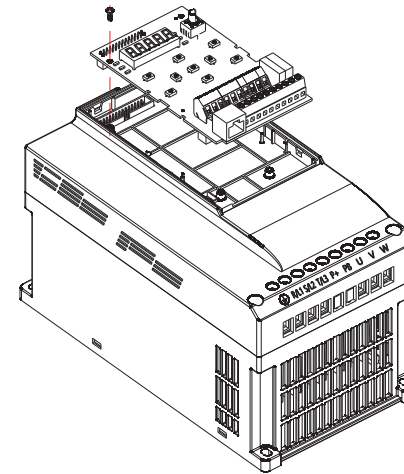

H0110 card mechanical installation drawing

16.3 Wiring diagram

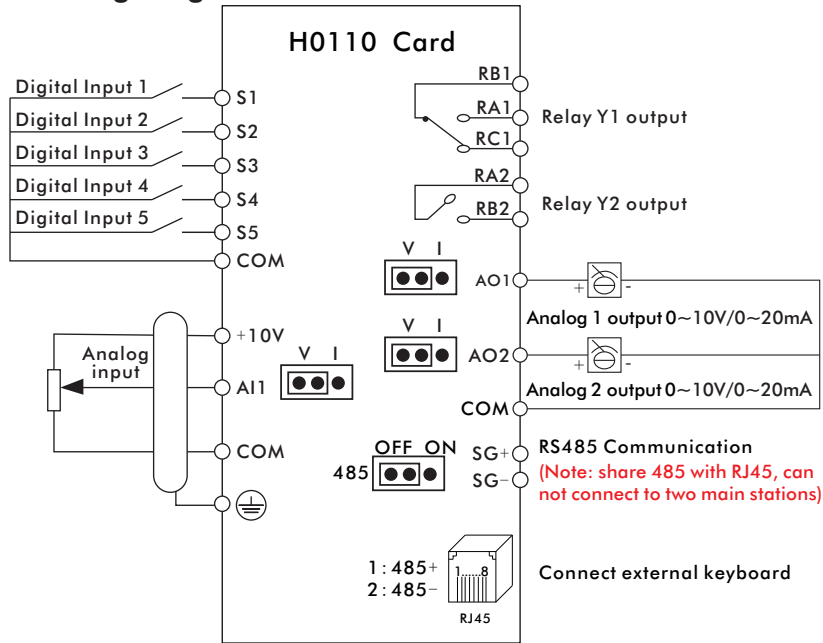

16.4 Control terminal

16.4.1 Terminal specifications

| Terminal symbol | Terminal name | Function Description |
|-----------------|---|--|
| +10V | 10V power supply | Provide +10 V power supply, maximum output current 50 mA |
| AI1 | Analog input terminal | 1. Input voltage range: DC 0V ~ 10V 2. Input current range: 0 ~ 20mA 3. Select voltage or current through AI1 jumper |
| AO1 | Analog output 1 | 1. Input voltage range: DC 0V ~ 10V 2. Input current range: 0 ~ 20mA 3. Select voltage or current through AO1 or AO2 jumper |
| AO2 | Analog output 2 | |
| COM | Digital, analog | Internal isolation from communication ground GND |
| S1~S5 | Digital input terminal | 1. Optocoupler isolation 2. Input impedance: 2.4kΩ 3. Voltage range during level input, 9V ~ 30V |
| RA1,RB1,RC1 | Relay output (one path is always open, one path is always closed) | Contact capacity: 250VAC 3A/30VDC 3A |
| RA2,RB2 | Relay output (Default open) | Contact capacity: 250VAC 5A/30VDC 5A |
| SG+,SG- | 485 Communication terminals | RJ45 network port can be connected to the external keypad. Note: The 485 communication terminal and the network port share one 485, cannot be connected to the master station of two stations at same time. |
| RJ45 | 485 Communications network | |

16.4.2 Terminal wiring

A. Digital input terminal:

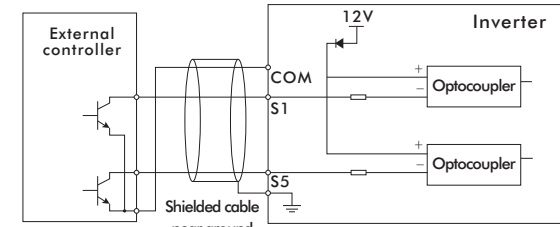

Digital input terminal wiring

Description: The wiring mode of the digital input terminal of the H0110 card is NPN type. If the user needs other wiring methods, please consult our technical staff.

B. Analog input terminal:

Because weak analog voltage signals are particularly susceptible to external interference, shielded cables are generally required, and the wiring distance should be as short as possible, not exceeding 20 meters. As shown below:

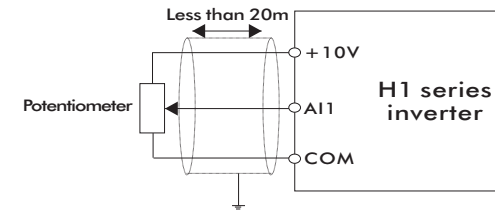

Analog input terminal wiring diagram

At some occasions where the analog signal is severely interfered, the analog signal source needs to add a filter capacitor or a ferrite core. As shown below:

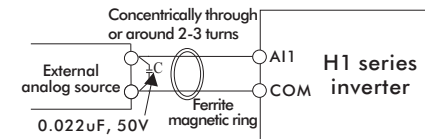

Analog input terminal acceleration filter wiring diagram

16.5 H0110 card application engraving machine instructions

16.5.1 Wiring diagram

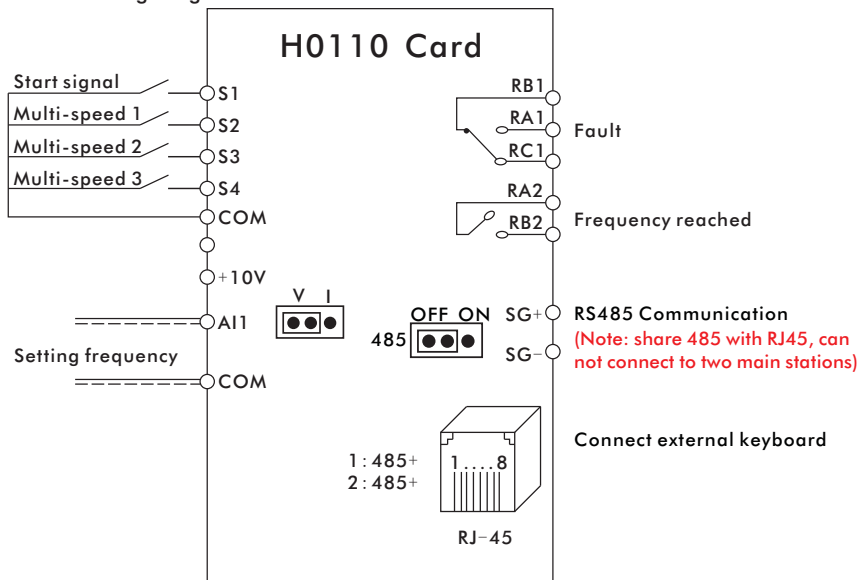

Engraving machine wiring diagram

16.5.2 Engraving machine debugging steps

- Connect according to the wiring diagram of the engraving machine, connect to S2, S3, S4 for multi-speed speed control; connect to AI1, COM for analog speed control.
- Power on, check the engraving machine application macro parameter P01.20=84 (set at the factory).
- Set the motor rated power, voltage, frequency, current, and speed according to the motor nameplate.
- If user parameters need to be adjusted, please refer to the user parameter table for setting.
- After the parameters are adjusted, the inverter can be started, stopped and speed adjusted through the system.
- The multi-speed table is as follows:

| S4 | S3 | S2 | Effective multi-speed | Application macro setting frequency |
|----|----|----|-----------------------|-------------------------------------|
| 0 | 0 | 1 | Multi-speed 1 | 100Hz |
| 0 | 1 | 0 | Multi-speed 2 | 150Hz |
| 0 | 1 | 1 | Multi-speed 3 | 200Hz |
| 1 | 0 | 0 | Multi-speed 4 | 250Hz |
| 1 | 0 | 1 | Multi-speed 5 | 300Hz |
| 1 | 1 | 0 | Multi-speed 6 | 350Hz |
| 1 | 1 | 1 | Multi-speed 7 | 400Hz |

0: No signal on S terminal; 1: Signal on S terminal
 Note: If the inverter cannot work after the user parameter is modified, first restore the factory value P01.11=2, then set the engraving machine application macro P01.20=84.

16.5.3 Engraving machine user parameter table

| Parameter number | Functions | Application macro setting value | Setting area |
|------------------|------------------------------------|--------------------------------------|--|
| P01.11 | Parameter operation | 0 | 0: Normal operation; 1: Initialize the parameters except P01.XX and application macro; 2: Initialize all parameters; |
| P01.20 | Macro program | 84 | 0~9999 84: Engraving machine macro |
| P02.00 | Multi-speed source | 1110 | 0~11111111 Bit: S1; Ten: S2; Hundred: S3; Thousand: S4; ... |
| P02.10 | Setting value source 1 | 1 | 0: Keyboard; 1: Multi-speed; 2: AI1; 3: AI2; 5: Communication; |
| P02.12 | Setting value source 3 | 2 | |
| P02.18 | Maximum setting value | 400Hz | 0.000~99999.000 |
| P02.31 | Multi-speed 1 | 25% | ~1000.000~1000.000 (Relative to the maximum set value percentage) |
| P02.32 | Multi-speed 2 | 37.5% | |
| P02.33 | Multi-speed 3 | 50% | |
| P02.34 | Multi-speed 4 | 62.5% | |
| P02.35 | Multi-speed 5 | 75% | |
| P02.36 | Multi-speed 6 | 87.5% | |
| P02.37 | Multi-speed 7 | 100% | |
| P02.50 | Acceleration time 0 | 5s | 0.000~3600.000 |
| P02.70 | Deceleration time 0 | 5s | |
| P03.00 | Start command source | 3 | 0: No effect; 1: Keyboard; 2: Communications; 3: S1; 4: S2; 5: S3; 6: S4; |
| P03.30 | Y1 Terminal Source (RA1, RB1, RC1) | 4 | 3: Running 4: Fault 5: Warning 6: Reversing 7: Ready 1350: Zero-speed operation 1351: Frequency reached Note: After setting the engraving machine application macro, then 1350 and 1351 will work |
| P03.32 | Y2 Terminal Source (RA2, RB2) | 1351 | |
| P06.11 | Motor rated power | Set according to the motor nameplate | 0.000~100000.000kW |
| P06.12 | Motor rated voltage | Set according to the motor nameplate | 0~1000V |
| P06.13 | Motor rated frequency | Set according to the motor nameplate | 1~3000Hz |
| P06.14 | Motor rated current | Set according to the motor nameplate | 0.00~1000.00A |
| P12.06 | Motor rated speed | Set according to the motor nameplate | 10~65535rpm |

16.6 H0110 card application constant pressure water supply instructions

16.6.1 Wiring diagram

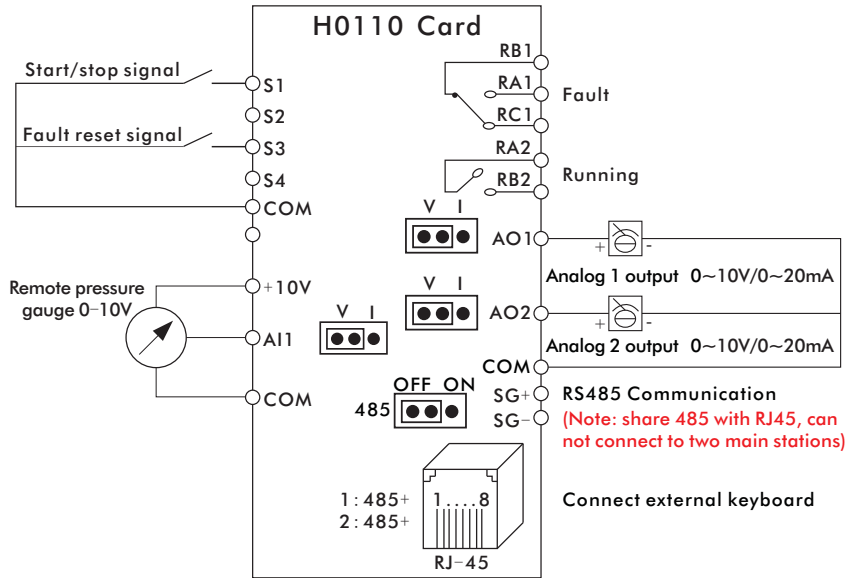

Constant pressure water supply wiring diagram

Note 1: Inverter start and stop control mode is divided into two lines (P03.20=0) and three lines (P03.20=2), wiring diagram as follows:

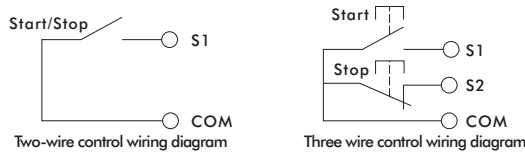

Note 2: The pressure feedback of the water pump is divided into a remote pressure gauge and a pressure sensor. The pressure sensor wiring is divided into two-wire and three-wire types. The wiring diagram is as follows

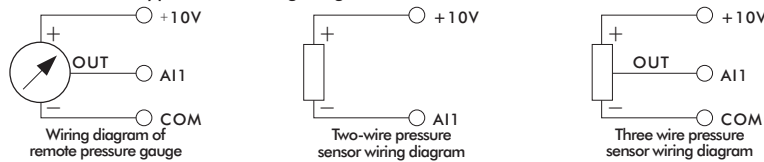

16.6.2 Constant pressure water supply debugging steps

- Wiring according to constant pressure water supply wiring diagram
- Power on, set constant pressure water supply application macro P01.20=86, the default pressure feedback signal is 0~10V corresponding to 0~16 kg.
- Set motor rated power, voltage, frequency and current according to motor nameplate.
- If user parameters need to be adjusted, please refer to the user parameter table settings.
- After adjusting the parameters, the inverter can be started and stopped by external switch

The keyboard displays the \bar{H} to show set pressure and the \bar{L} to show actual pressure

Note: If the inverter cannot work normally after the user parameters are modified, first restore the factory value P01.11=2, and then set the constant pressure water supply application macro P01.20=86.

16.6.3 Constant pressure water supply user parameter table

| Parameter number | Functions | Application macro setting value | Setting area |
|------------------|-------------------------------------|--------------------------------------|--|
| P01.11 | Parameter operation | 0 | 0: Normal operation; 1: Initialize the parameters except P01.XX and application macro; 2: Initialize all parameters; |
| P01.20 | Macro program | 86 | 0~9999 86: Constant pressure water supply macro |
| P02.03 | Source of incremental command(UP) | 1 | Bit: keyboard; Ten: communication; Hundred: S1; Thousand: S2; ... |
| P02.04 | Source of decremental command(DOWN) | 1 | |
| P02.11 | Feedback values | 2 | 0: keyboard; 1: Multi-speed; 2: AI1; |
| P02.13 | Setting relationship selection | 8 | 8: PID |
| P02.18 | Maximum set value | 50Hz | 0.000~99999.000 |
| P02.28 | Lift rate | 0% | -1000.000~1000.000 |
| P02.92 | Set value | 5kg | -1000.000~1000.000 |
| P03.00 | Start command source | 3 | 0: No effect; 1: keyboard; |
| P03.04 | Stop command source | 0 | 2: Communication; 3: S1; |
| P03.07 | Reset command source | 5 | 4: S2; 5: S3; 6: S4; |
| P03.20 | S1 type | 0 | 0: Positive logic; 1: Reverse logic; |
| P03.21 | S2 type | 1 | 2: Rising edge; 3: Falling edge |
| P03.30 | Y1 terminal source (RA1, RB1, RC1) | 4 | 0: Always 0; 1: Always 1; |
| P03.32 | Y2 terminal source (RA2, RB2) | 3 | 2: Stopped; 3: Running; |
| | | | 4: Fault; 5: Warning; |
| | | | 6: Reversing; 7: Ready |
| P03.41 | Ai1 low-end voltage (current) | 0V(mA) | -999999.000~999999.000 |
| P04.00 | PID proportional gain | 0.010% | 0.000~10.000 |
| P04.01 | PID integration time | 10.000s | 0.001~9999.000 |
| P04.02 | PID differential gain | 0.000% | 0.000~9999.000 |
| P04.05 | PID output upper limit | 100.000% | -1000.000~1000.000 |
| P04.06 | PID output lower limit | 0.000% | (100% relative maximum set value) |
| P04.09 | PID range | 16kg | 0.001~99999.000 |
| P04.11 | PID sleep frequency | 40% | 0.000~500.000 (100% relative maximum set value) |
| P04.12 | PID enter sleep time | 10s | 0.000~3600.000 |
| P04.13 | PID wake-up deviation | 20% | 0.000~100.000 (Relative setting pressure is 100 %) |
| P04.14 | PID enter wake-up time | 2s | 0.000~3600.000 |
| P04.15 | PID sleep action | 4 | 0: No sleep; 1: PID Stop; |
| | | | 2: Decelerate to stop; 3: Free parking; |
| | | | 4: Pause; |
| | | | 5: Minimum frequency operation |
| P05.00 | Control mode | 0 | 0: VF; 1: Open loop vector1 |
| P06.11 | Motor rated power | Set according to the motor nameplate | 0.000~100000.000 |
| P06.12 | Motor rated voltage | Set according to the motor nameplate | 0~1000 |
| P06.13 | Motor rated frequency | Set according to the motor nameplate | 1~3000 |
| P06.14 | Motor rated current | Set according to the motor nameplate | 0.00~1000.00 |
| P12.00 | Dry pump detection frequency | 25Hz | 0.000~999999.000 |
| P12.01 | Dry pump detection current | 0A | 0.000~999999.000 0: Dry pump test closed |
| P12.02 | Breakline detection voltage | 0V | 0.000~999999.000 0: Disconnection detection off |

CHAPTER 17 - Standard card (H0100) Instructions

17.1 Overview

H0100 card is a multifunction I/O card used in H1 series. It can realize two digital input, one relay output and one analog input, and also has RS-485 communication interface, can be connected to the external keyboard.

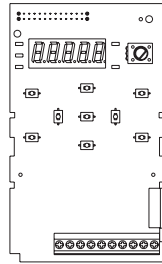

H0100 card distribution diagram

17.2 Mechanical installation

Please install when the inverter is completely powered off; align the pins(26 pins) on the H0100 card and the inverter power board plug tightly.

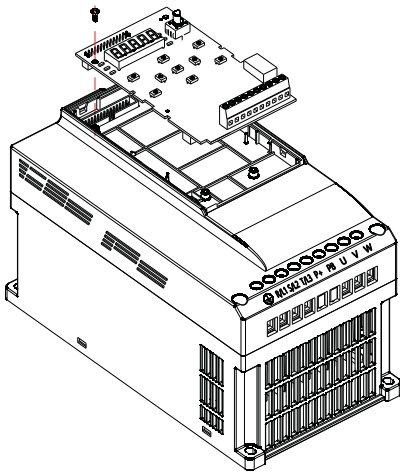

H0100 card mechanical installation drawing

17.3 Wiring diagram

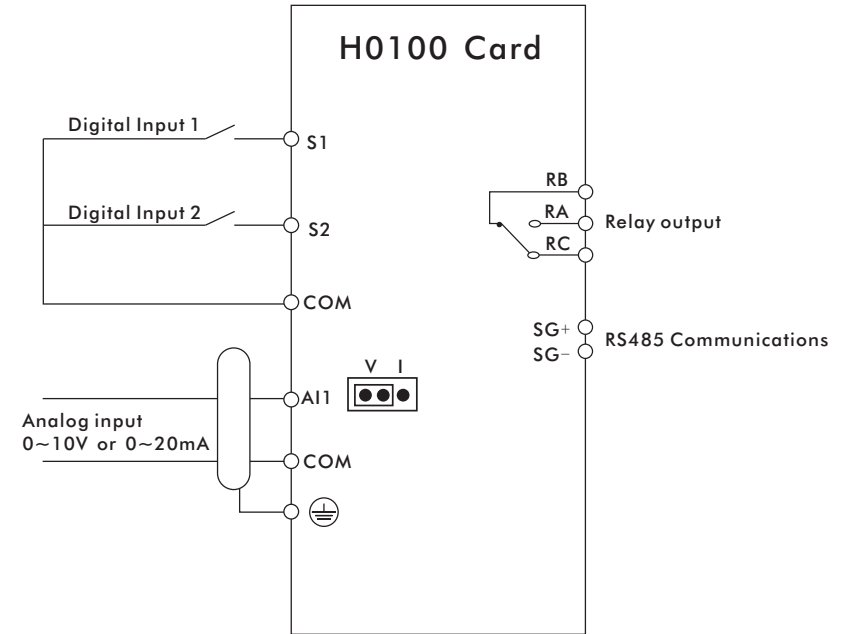

17.4 Control terminal

17.4.1 Terminal specifications

| Terminal symbol | Terminal name | Function Description |
|-----------------|---|--|
| +10V | Reserved terminals | No power output |
| AI1 | Analog input terminal | 1. Input voltage range: DC 0V ~ 10V 2. Input current range: 0 ~ 20mA 3. Select voltage or current through AI1 jumper |
| COM | Digital, analog | Internal isolation from communication ground GND |
| S1~S2 | Digital input terminal | 1. Optocoupler isolation 2. Input impedance: 2.4kΩ 3. Voltage range during level input, 9V ~ 30V |
| RA, RB, RC | Relay output (one path is always open , one path is always closed) | Contact capacity: 250VAC 3A/30VDC 3A |
| SG+,SG- | 485 Communication terminals | Connect to the upper computer |

17.4.2 Terminal wiring

A. Digital input terminal:

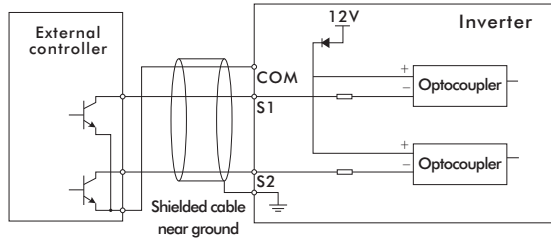

Digital input terminal wiring

Note: The wiring mode of the digital input terminal of the H0100 card is NPN type. If users need other wiring methods, please consult our technicians.

B. Analog input terminal:

Because the analog voltage signal is particularly susceptible to external interference, it is generally necessary to use a shielded cable, and the wiring distance should be as short as possible, not more than 20 meters. As shown below:

In some situations where analog signals are severely disturbed, a filter capacitor or ferrite core must be added to the analog signal source side. As shown below:

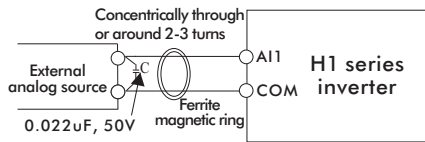

Analog input terminal plus filter processing wiring diagram

CHAPTER 18 - H0200 Card instructions for use

18.1 Overview

H0200 card is a multifunctional I/O card for H1 series inverters. It can realize 10 digital inputs, 3 relay outputs, 2 analog inputs, 2 analog outputs, STO input, and also has RS-485 communication interface, can be connected to the upper computer.

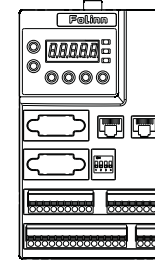

H0200 card distribution diagram

18.2 Mechanical installation

Please install when the inverter is completely powered off; align the pins(26 pins) on the H0200 card and the inverter power board plug tightly.

Warning: It is strictly forbidden to plug or unplug the H0200 card with power on!

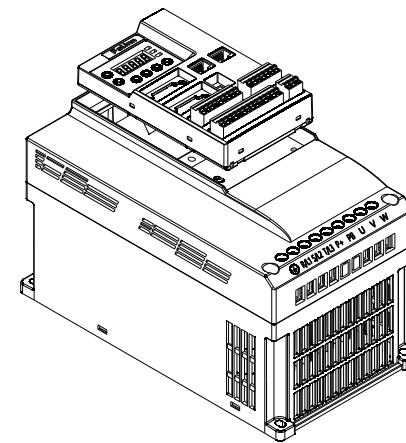

H0200 card mechanical installation drawing

18.3 Wiring diagram

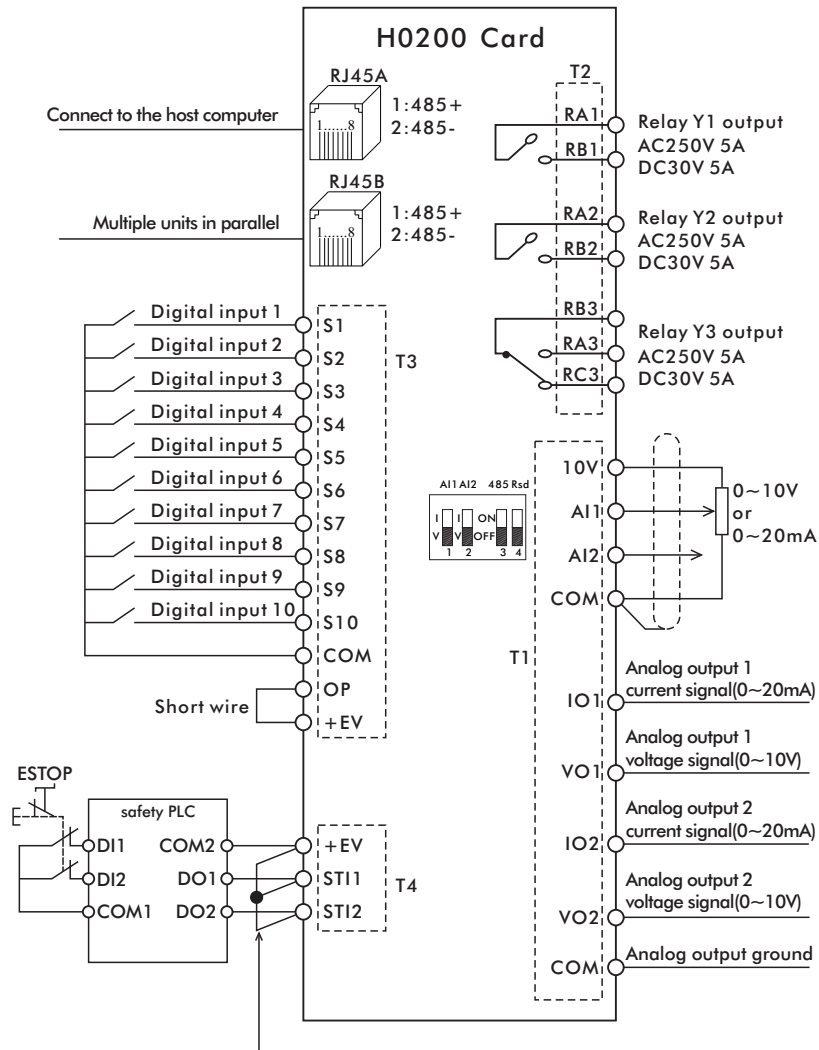

This is the factory short wiring between +EV,ST11 and ST12, To use safety function wiring, please remove this short wire.

H0200 Function Card

18.4 Control terminal

18.4.1 Terminal specifications

| Input and output signal description | | | | |
|-------------------------------------|---------------|-----|------|--|
| Port | Type | Pin | Name | Function |
| RJ45A | Communication | 1 | 485+ | 485 communication (MODBUS RTU), two network ports share one 485 interface, and cannot be connected to two master stations at the same time |
| RJ45B | | 2 | 485- | |
| T1 | Analog input | 1 | 10V | 10V power terminal |
| | | 2 | AI1 | Analog input 1 (0~10V or 0~20mA) |
| | | 3 | AI2 | Analog input 2 (0~10V or 0~20mA) |
| | | 4 | COM | COM |
| | Analog output | 5 | IO1 | Analog output 1 current signal (0~20mA) |
| | | 6 | VO1 | Analog output 1 voltage signal (0~10V) |
| | | 7 | IO2 | Analog output 2 current signal (0~20mA) |
| | | 8 | VO2 | Analog output 2 voltage signal (0~10V) |
| 9 | COM | COM | | |
| T2 | Relay output | 1 | RA1 | Relay Y1 output (1 normally open) |
| | | 2 | RB1 | |
| | | 3 | RA2 | Relay Y2 output (1 normally open) |
| | | 4 | RB2 | |
| | | 5 | RA3 | Relay Y3 output (1 normally open, 1 normally closed) |
| | | 6 | RB3 | |
| | | 7 | RC3 | |
| T3 | Digital input | 1 | COM | COM |
| | | 2 | S1 | Digital input 1 |
| | | 3 | S2 | Digital input 2 |
| | | 4 | S3 | Digital input 3 |
| | | 5 | S4 | Digital input 4 |
| | | 6 | S5 | Digital input 5 |
| | | 7 | S6 | Digital input 6 |
| | | 8 | S7 | Digital input 7 |
| | | 9 | S8 | Digital input 8 |
| | | 10 | S9 | Digital input 9 |
| | | 11 | S10 | Digital input 10 |
| T3 | Control power | 12 | COM | COM |
| | | 13 | OP | External power input terminal (short-circuit between OP and +EV) |
| | | 14 | +EV | 12V power terminal |
| | | | | |
| T4 | STO | 1 | +EV | 12V power terminal (from factory + EV,ST11 and ST12 are shorted) |
| | | 2 | ST11 | STO input 1 |
| | | 3 | ST12 | STO input 2 |

H0200 Function Card

18.4.2 Terminal wiring

A. Digital input terminal wiring:

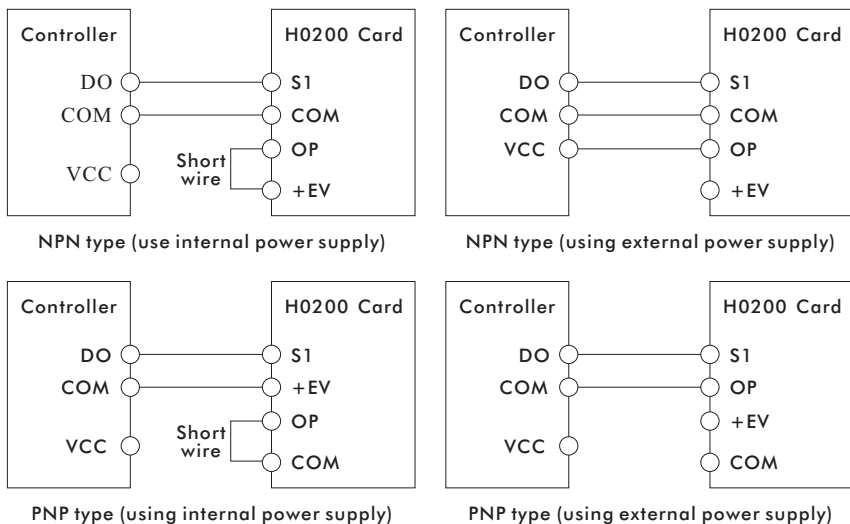

18.5 Operator description

18.5.1 Keyboard appearance and key description

| No. | Structure | Function Description |
|-----|------------|---|
| 1 | Display | Display |
| 2 | PRE | Programming/Exit key |
| 3 | Left Arrow | In the state display interface, it is the state switch key; in other interfaces, it is the left shift key, Long press 2S to confirm |
| 4 | Run | Run key |
| 5 | Up Arrow | In programming mode: the value change key, In non-programming mode: the UP/DOWN selection key, |
| 6 | Down Arrow | See parameters P01.63, P02.03, P02.04 |
| 7 | Stop/Reset | Stop/reset key |

Figure H0200 Keyboard

18.5.2 Indicator function description

| Indicator | Status | Function Description |
|-----------|-----------------|----------------------------------|
| RUN | Bright/flashing | Running/decelerating |
| ALM | Bright | Fault indication |
| M | Bright | Customer customized instructions |

18.5.3 Display description

| Monitoring item | Display item description | Monitoring item | Display item description |
|-----------------|--------------------------|-----------------|--------------------------------------|
| F | Output frequency | H | Display value 1 (selected by P01.68) |
| C | Output current | L | Display value 2 (selected by P01.69) |
| U | The output voltage | A | Current alarm |
| d | DC bus voltage | E | Current fault |

18.6 Inverter safety switch STO function

18.6.1 Function description

H1 series H0200 function card provides safe torque off (STO, Safe Torque Off) function, through STI1 and STI2 signal input to turn off IGBT, and then prevent the generation of motor torque, in order to achieve the purpose of safe stop.

18.6.2 Safety input terminal function detailed description

| Terminal name | Function Description |
|---------------|--|
| +EV | When the STO function is not used, STI1 and STI2 can be short wired by +EV |
| STI1 | STO function channel 1 signal input |
| STI2 | STO function channel 2 signal input |

Table 1 Terminal function description

The operation logic and keyboard display description after STI1/STI2 signal input is as follows:

| Signal | Status | | | |
|---------------------------|---------------------|------------------------------|------------------------------|-----------------------------|
| STI1 and +EV | ON | OFF | ON | OFF |
| STI2 and +EV | ON | ON | OFF | OFF |
| Inverter output | Ready to output | STI1 mode Torque output stop | STI2 mode Torque output stop | STO mode Torque output stop |
| Keyboard abnormal display | No abnormal display | E0034 | E0035 | E0033(P09.49=2) |

Table 2 Action logic and keyboard display description

E0033 indicates that STI1 and STI2 operate at the same time.

E0034 indicates STI1 operation.

E0035 indicates STI2 operation.

E0036 indicates that the internal STO circuit of STI1 is diagnosed as abnormal.

18.6.3 Wiring diagram

- A. The internal circuit diagram of the safety control loop is shown in Figure 1 below.
- B. When from factory, the terminals +EV, STI1, and STI2 in the safety control circuit are shorted together with short wires, as shown in the red box.
- C. The wiring of the safety control circuit using the inverter is as follows.
 - (1) Remove the +EV, STI1, and STI2 short wires.
 - (2) The wiring is shown in Figure 2 below. When normal, the ESTOP contact of the switch must be closed so that the inverter can output and not jump abnormally.
 - (3) In STO mode, the switch ESTOP opens. The inverter stops output and the panel displays E0033.

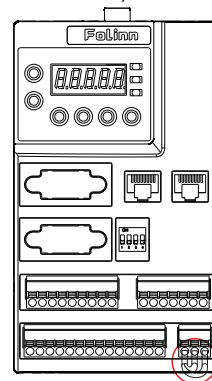

Figure 1

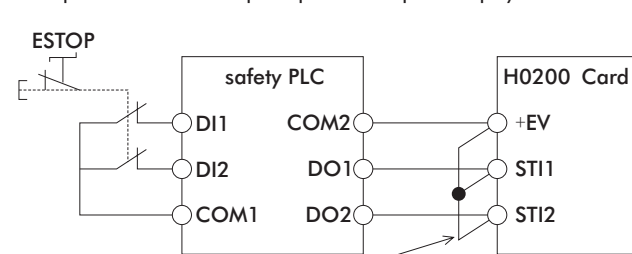

Figure 2

This is the factory short wiring between +EV and STI1 and STI2. To use the safety function wiring, please remove this short wiring. On the contrary, if the safety function is turned off, +EV must be shorted together with STI1 and STI2.

CHAPTER 19 - H0201 Card instructions for use

19.1 Overview

H0201 card is a multifunctional I/O card for H1 series inverters. It can realize 10 digital inputs, 3 relay outputs, 2 analog inputs, 2 analog outputs, and also has RS-485 communication interface, can be connected to the upper computer.

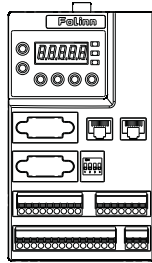

H0201 card distribution diagram

19.2 Mechanical installation

Please install when the inverter is completely powered off; align the pins(26 pins) on the H0201 card and the inverter power board plug tightly.

Warning: Do not to plug or unplug the H0201 card when powered!

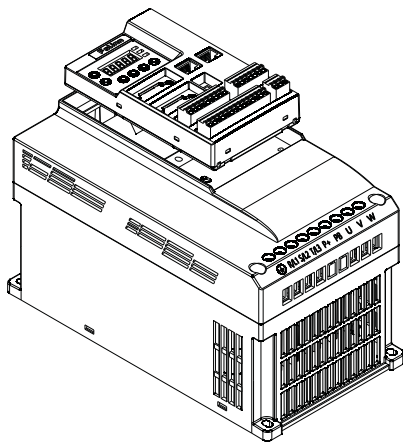

H0201 card mechanical installation drawing

19.3 Wiring diagram

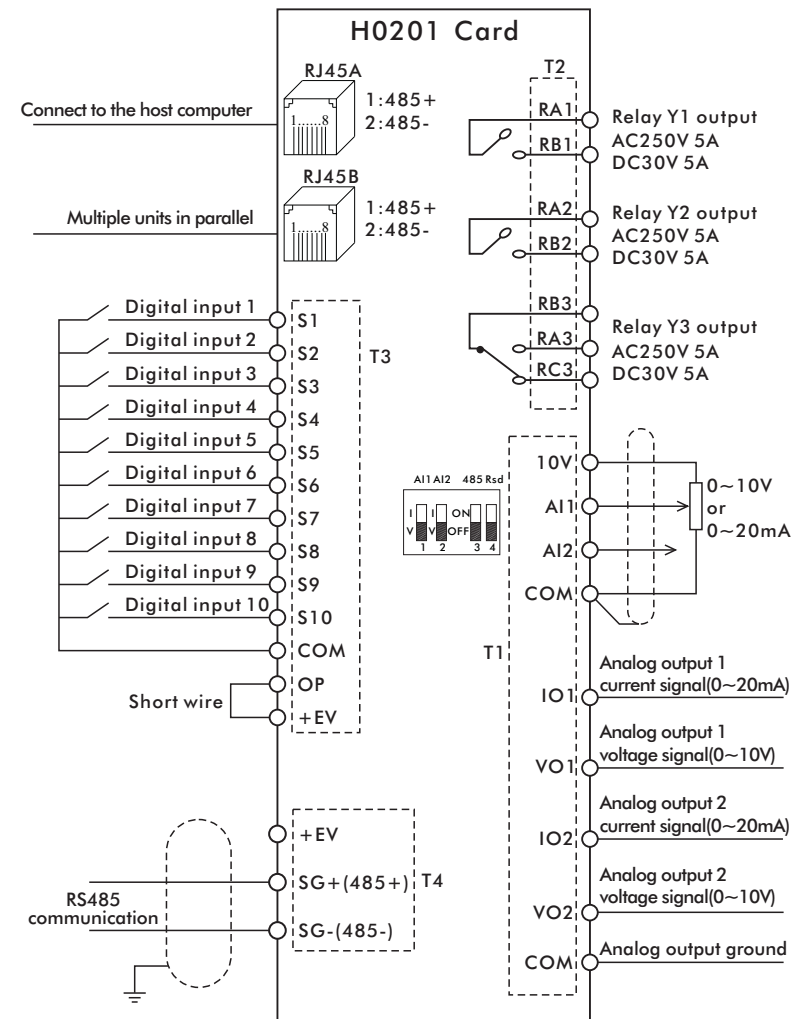

19.4 Control terminal

19.4.1 Terminal specifications

| Input and output signal description | | | | |
|-------------------------------------|---------------|-----|------|--|
| Port | Type | Pin | Name | Function |
| RJ45A | Communication | 1 | 485+ | 485 communication (MODBUS RTU), two network ports share one 485 interface, and cannot be connected to two master stations at the same time |
| RJ45B | | 2 | 485- | |
| T1 | Analog input | 1 | 10V | 10V power terminal |
| | | 2 | AI1 | Analog input 1 (0~10V or 0~20mA) |
| | | 3 | AI2 | Analog input 2 (0~10V or 0~20mA) |
| | | 4 | COM | COM |
| | Analog output | 5 | IO1 | Analog output 1 current signal (0~20mA) |
| | | 6 | VO1 | Analog output 1 voltage signal (0~10V) |
| | | 7 | IO2 | Analog output 2 current signal (0~20mA) |
| | | 8 | VO2 | Analog output 2 voltage signal (0~10V) |
| | | 9 | COM | COM |
| T2 | Relay output | 1 | RA1 | Relay Y1 output (1 normally open) |
| | | 2 | RB1 | |
| | | 3 | RA2 | Relay Y2 output (1 normally open) |
| | | 4 | RB2 | |
| | | 5 | RA3 | Relay Y3 output (1 normally open, 1 normally closed) |
| | | 6 | RB3 | |
| | | 7 | RC3 | |
| T3 | Digital input | 1 | COM | COM |
| | | 2 | S1 | Digital input 1 |
| | | 3 | S2 | Digital input 2 |
| | | 4 | S3 | Digital input 3 |
| | | 5 | S4 | Digital input 4 |
| | | 6 | S5 | Digital input 5 |
| | | 7 | S6 | Digital input 6 |
| | | 8 | S7 | Digital input 7 |
| | | 9 | S8 | Digital input 8 |
| | | 10 | S9 | Digital input 9 |
| | | 11 | S10 | Digital input 10 |
| | Control power | 12 | COM | COM |
| | | 13 | OP | External power input terminal (short-circuit between OP and +EV) |
| | | 14 | +EV | 12V power terminal |
| T4 | Communication | 1 | +EV | 12V power terminal |
| | | 2 | SG+ | It shares a 485 interface with RJ45A and RJ45B, and cannot connect to two master stations for communication at the same time |
| | | 3 | SG- | |

19.4.2 Terminal wiring

A. Digital input terminal wiring:

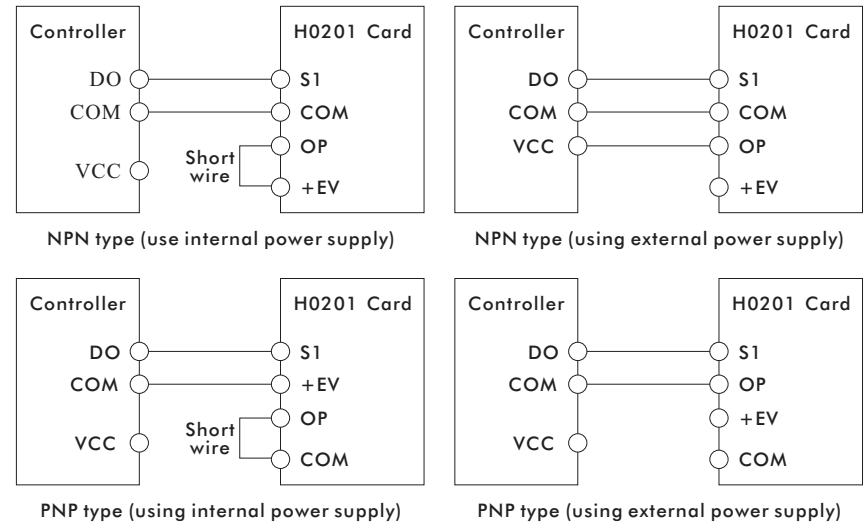

19.5 Operator description

19.5.1 Keyboard appearance and key description

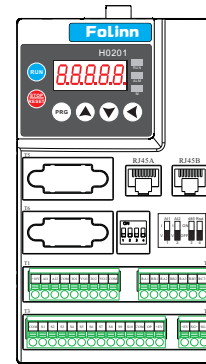

| No. | Structure | Function Description |
|-----|-----------|---|
| 1 | 8888.88 | Display |
| 2 | PRG | Programming/Exit key |
| 3 | ◀ | In the state display interface, it is the state switch key; in other interfaces, it is the left shift key, Long press 2S to confirm |
| 4 | ▶ | Run key |
| 5 | ▲ | In programming mode: the value change key, In non-programming mode: the UP/DOWN selection key, |
| 6 | ▼ | See parameters P01.63, P02.03, P02.04 |
| 7 | STOP | Stop/reset key |

Figure H0201 Keyboard

19.5.2 Indicator function description

| Indicator | Status | Function Description |
|-----------|------------------|----------------------------------|
| RUN | Bright/ flashing | Running/decelerating |
| ALM | Bright | Fault indication |
| M | Bright | Customer customized instructions |

19.5.3 Display description

| Monitoring item | Display item description | Monitoring item | Display item description |
|-----------------|--------------------------|-----------------|--------------------------------------|
| F | Output frequency | H | Display value 1 (selected by P01.68) |
| I | Output current | L | Display value 2 (selected by P01.69) |
| U | The output voltage | A | Current alarm |
| d | DC bus voltage | E | Current fault |

CHAPTER 20 - OP-H101 external keyboard simple instructions

20.1 Overview

OP-H101 is an optional external keyboard for H1 series inverters, and the RS485 communication with the local keyboard is connected through a straight-through twisted pair network cable.

20.2 Keyboard features

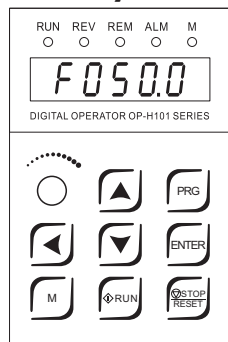

| No. | Structure | Function Description |
|-----|-----------------|---------------------------------|
| 1 | F0500 | Display |
| 2 | [Potentiometer] | Potentiometer |
| 3 | [Left Shift] | State switch key left shift key |
| 4 | [Up Arrow] | Increment key |
| 5 | [Down Arrow] | Decrement key |
| 6 | [PRG] | Programming/Exit key |
| 7 | [ENTER] | Enter |
| 8 | [RUN] | Run key |
| 9 | [STOP/RESET] | Stop/reset key |
| 10 | [M] | Customized keys |

| Indicator | Status | Function Description |
|------------|-----------------|---|
| RUN | Bright/flashing | Running/decelerating |
| REV | Bright | Reversing |
| REM | Bright | Remote start |
| ALM | Bright | Error indication |
| M | Bright | Customized instructions, default alarm instructions |

20.3 Parameter setting and description

| Code | Parameter Name | Value | Unit/Description | Description | |
|--------|-------------------------------|---------------------|--|--|--|
| P01.41 | Local address | 1 (Factory default) | Slave address | The communication parameter setting value of the inverter must be equal to the factory value, otherwise the inverter and the external keyboard cannot communicate, and the external keyboard will always display the version number U****. | |
| P01.42 | Baud rate | 3 (Factory default) | 19200bps | | |
| P01.43 | Parity check | 0 (Factory default) | No check | | |
| P01.45 | Stop bit | 1 (Factory default) | 1 bit | | |
| P01.63 | Keyboard setting source | 1 | Potentiometer speed | | |
| | | 0 | Increase and decrease keys for speed control | 1. When the keyboard setting source P01.63 setting value is changed, it needs to be re-powered to be effective. | |
| P02.10 | Set value source 1 | 5 | Speed control enable | | 2. After operating the M key to make the inverter stop freely, it needs to be re-powered to start. |
| P02.03 | Increase (UP) select source | 10 | Increment key to increase frequency | | |
| P02.04 | Decrease (DOWN) select source | 10 | Decrease key to decrease frequency | 3. Customized M key command priority: Free stop command > JOG command > Reverse command. | |
| P03.00 | Start command source | 2 | Start-stop enable | | |
| P03.07 | Reset command source | 2 | Reset enable | | |
| P03.02 | Reverse command | 2 | M key reverse | | |
| P03.03 | JOG command | 2 | M key jog | | |
| P03.05 | Free parking command | 2 | M key free stop | | |

Note: In addition to the communication parameters (P01.41~P01.45) that need to be determined for the above parameters, other parameters are modified according to the function of the external keyboard keys. The corresponding parameters of the keys that do not need to be operated do not need to be changed!

20.4 Installation method and related dimensions

The OP-H101 external keyboard supports embedded installation, no external panel frame is required. The following figure shows the outline and opening dimensions of the OP-H101 external keyboard.

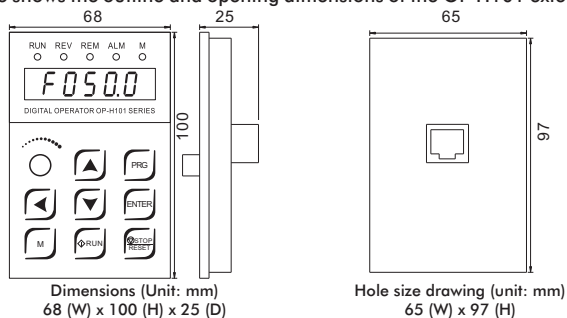

Dimensions (Unit: mm)
68 (W) x 100 (H) x 25 (D)

Hole size drawing (unit: mm)
65 (W) x 97 (H)

CHAPTER 21 - OP-H102 external keyboard simple instructions

21.1 Overview

OP-H102 is an optional external keyboard for H1 series inverters, and the RS485 communication with the local keyboard is connected through a straight-through twisted pair network cable.

21.2 Keyboard features

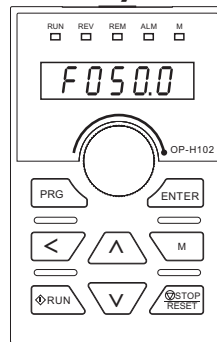

| No. | Structure | Function Description |
|-----|-----------------|---------------------------------|
| 1 | F0500 | Display |
| 2 | [Potentiometer] | Potentiometer |
| 3 | [Left Shift] | State switch key left shift key |
| 4 | [Up Arrow] | Increment key |
| 5 | [Down Arrow] | Decrement key |
| 6 | [PRG] | Programming/Exit key |
| 7 | [ENTER] | Enter |
| 8 | [RUN] | Run key |
| 9 | [STOP/RESET] | Stop/reset key |
| 10 | [M] | Customized keys |

| Indicator | Status | Function Description |
|------------|-----------------|---|
| RUN | Bright/flashing | Running/decelerating |
| REV | Bright | Reversing |
| REM | Bright | Remote start |
| ALM | Bright | Error indication |
| M | Bright | Customized instructions, default alarm instructions |

21.3 Parameter setting and description

| Code | Parameter Name | Value | Unit/Description | Description |
|--------|-------------------------------|---------------------|--|--|
| P01.41 | Local address | 1 (Factory default) | Slave address | The communication parameter setting value of the inverter must be equal to the factory value, otherwise the inverter and the external keyboard cannot communicate, and the external keyboard will always display the version number U****. |
| P01.42 | Baud rate | 3 (Factory default) | 19200bps | |
| P01.43 | Parity check | 0 (Factory default) | No check | |
| P01.45 | Stop bit | 1 (Factory default) | 1 bit | |
| P01.63 | Keyboard setting source | 1 | Potentiometer speed | |
| | | 0 | Increase and decrease keys for speed control | 1. When the keyboard setting source P01.63 setting value is changed, it needs to be re-powered to be effective. |
| P02.10 | Set value source 1 | 5 | Speed control enable | |
| P02.03 | Increase (UP) select source | 10 | Increment key to increase frequency | |
| P02.04 | Decrease (DOWN) select source | 10 | Decrease key to decrease frequency | 3. Customized M key command priority: Free stop command > JOG command > Reverse command. |
| P03.00 | Start command source | 2 | Start-stop enable | |
| P03.07 | Reset command source | 2 | Reset enable | |
| P03.02 | Reverse command | 2 | M key reverse | |
| P03.03 | JOG command | 2 | M key jog | |
| P03.05 | Free parking command | 2 | M key free stop | |

Note: In addition to the communication parameters (P01.41~P01.45) that need to be determined for the above parameters, other parameters are modified according to the function of the external keyboard keys. The corresponding parameters of the keys that do not need to be operated do not need to be changed!

21.4 Installation method and related dimensions

OP-H102 external keyboard installation requires the purchase panel frame to cooperate with the installation. The following figure shows the outline and opening dimensions of the panel frame.

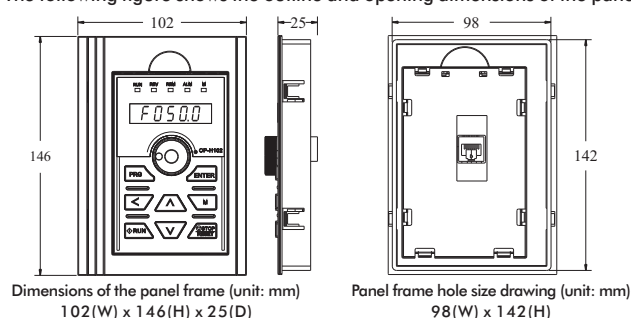

Dimensions of the panel frame (unit: mm)
102 (W) x 146 (H) x 25 (D)

Panel frame hole size drawing (unit: mm)
98 (W) x 142 (H)