

**User Manual**  
**For**  
**Worm Gear Speed Reducer**

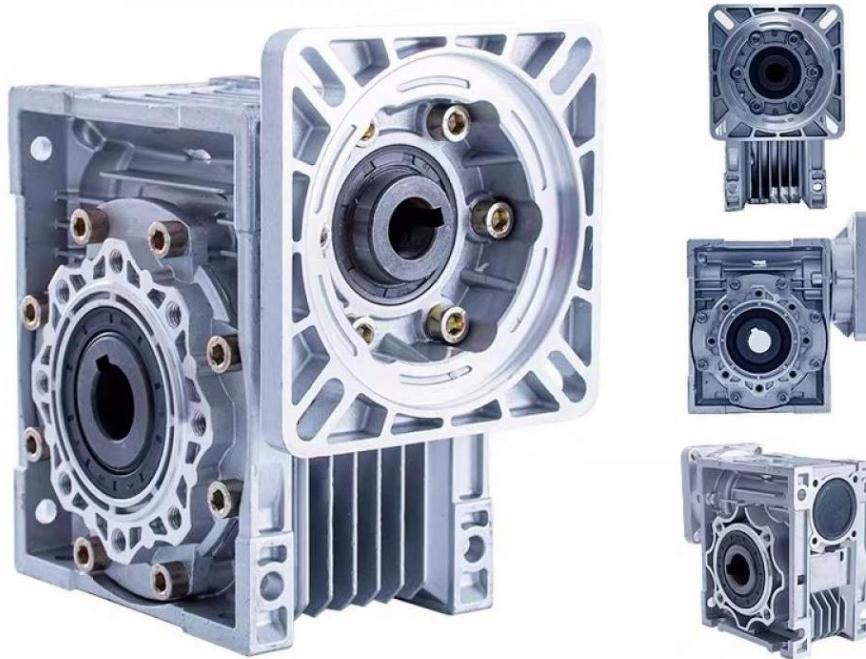

## Product summary

- Made of Aluminum alloy die-casting box, good looking in appearance, compact in structure rust proofing on Surface and small volume to save mounting space.
- Good radiating characteristic leads safe and high efficiency for using.
- The strong capacity of loading and overload ensure stable transmission, make less vibration and noise.
- Varies of connecting structure for power input and torque output meet different requirements; the design of box outline and the set of foot hole is apt to with many kinds of mounting.
- Besides big cases, no gap structure of box means a maintenance- free that is hermetically sealed. It prevents the lubricant from easily losing and going bad, and exchanging.

## Products Structure View



Model	Gear Ratio										
	5	7.5	10	15	20	25	30	40	50	60	80
<b>NMRV30</b>	Moment Permissible Torque(Nm)[lb-in]										
	18.00 [159.31]	18.00 [159.31]	18.00 [159.31]	18.00 [159.31]	18.00 [159.31]	20.00 [177.01]	20.00 [177.01]	17.00 [150.46]	17.00 [150.46]	17.00 [150.46]	12.00 [106.21]
	Efficiency										
	87%	85%	82%	76%	73%	67%	65%	58%	55%	52%	43%
	Shaft Maximum Radial Load(kN)										
	0.57	0.68	0.75	0.86	0.94	1.02	1.08	1.19	1.28	1.36	1.50
	Backlash@No-Load(°)										
1											

**Dimension**

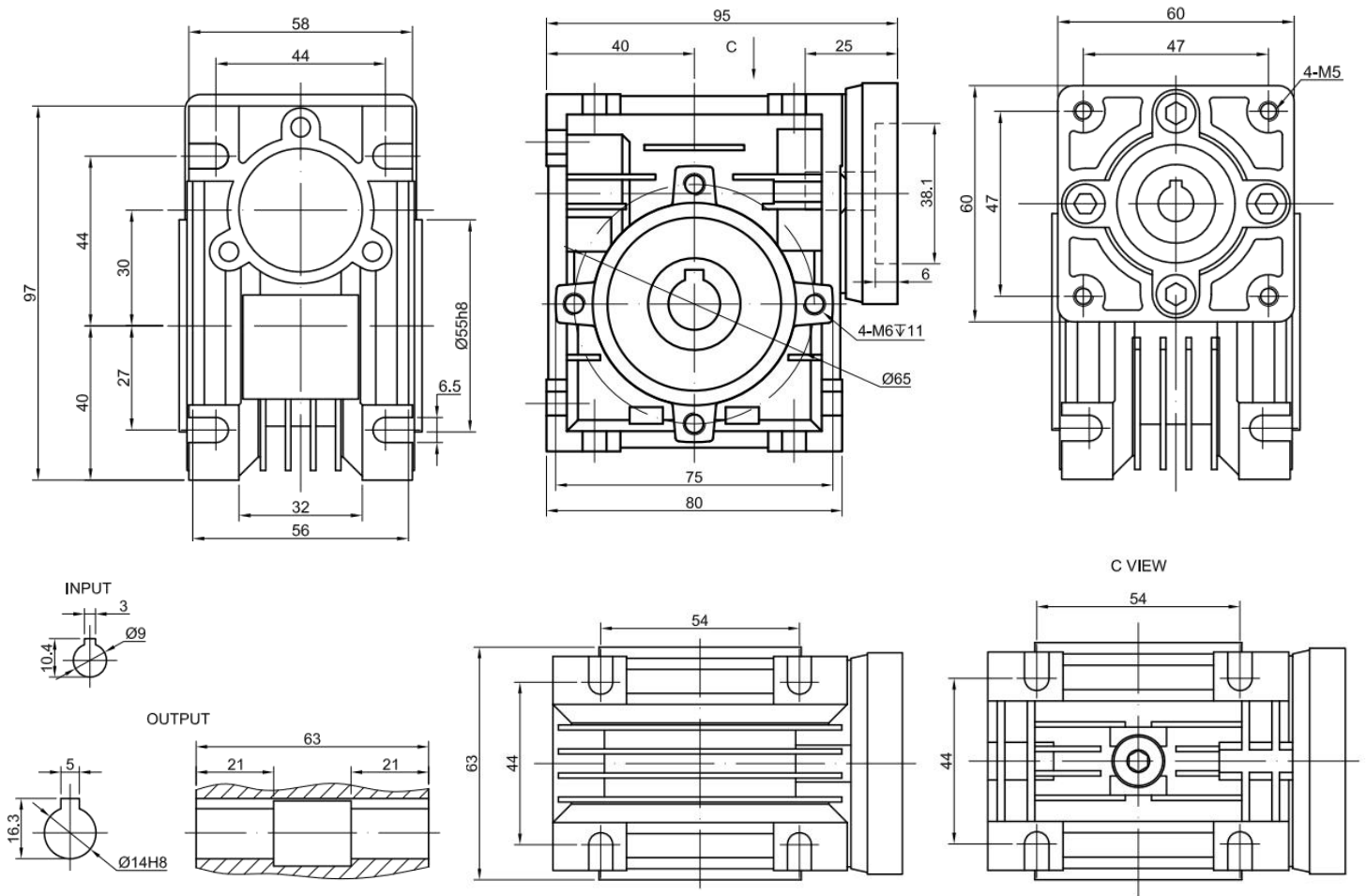

**Output Shaft**

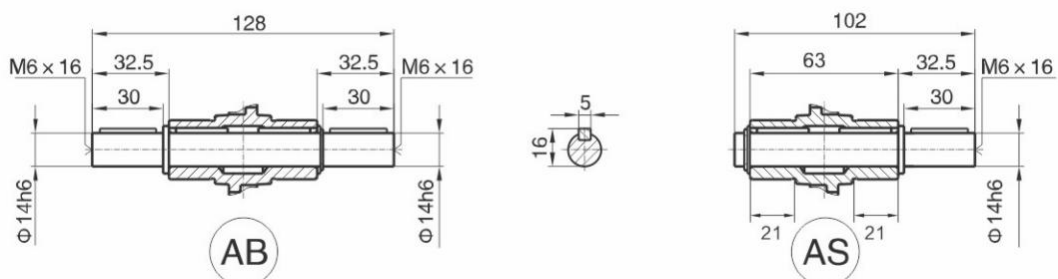

Model	Gear Ratio								
	5	7.5	10	15	20	25	30	40	50
<b>NMRV40</b>	Moment Permissible Torque(Nm)[lb-in]								
	40.00 [354.03]	40.00 [354.03]	40.00 [354.03]	40.00 [354.03]	40.00 [354.03]	40.00 [354.03]	45.00 [398.28]	40.00 [354.03]	38.00 [336.33]
	Efficiency								
	87%	85%	83%	82%	78%	75%	70%	65%	62%
	Shaft Maximum Radial Load(kN)								
	1.18	1.31	1.44	1.65	1.82	1.96	2.08	2.29	2.47
	Backlash@No-Load(°)								
1									

Dimension



Output Shaft



Model	Gear Ratio							
	5	7.5	10	15	20	25	30	50
<b>NMRV50</b>	Moment Permissible Torque(Nm)[lb-in]							
	73.00 [646.1]	72.00 [637.25]	70.00 [619.55]	75.00 [663.81]	70.00 [619.55]	70.00 [619.55]	85.00 [752.31]	74.00 [654.96]
	Efficiency							
	89%	88%	86%	82%	79%	76%	72%	63%
	Shaft Maximum Radial Load(kN)							
	1.57	1.80	1.98	2.27	2.5	2.69	2.86	3.39
	Backlash@No-Load(°)							
1								

Dimension

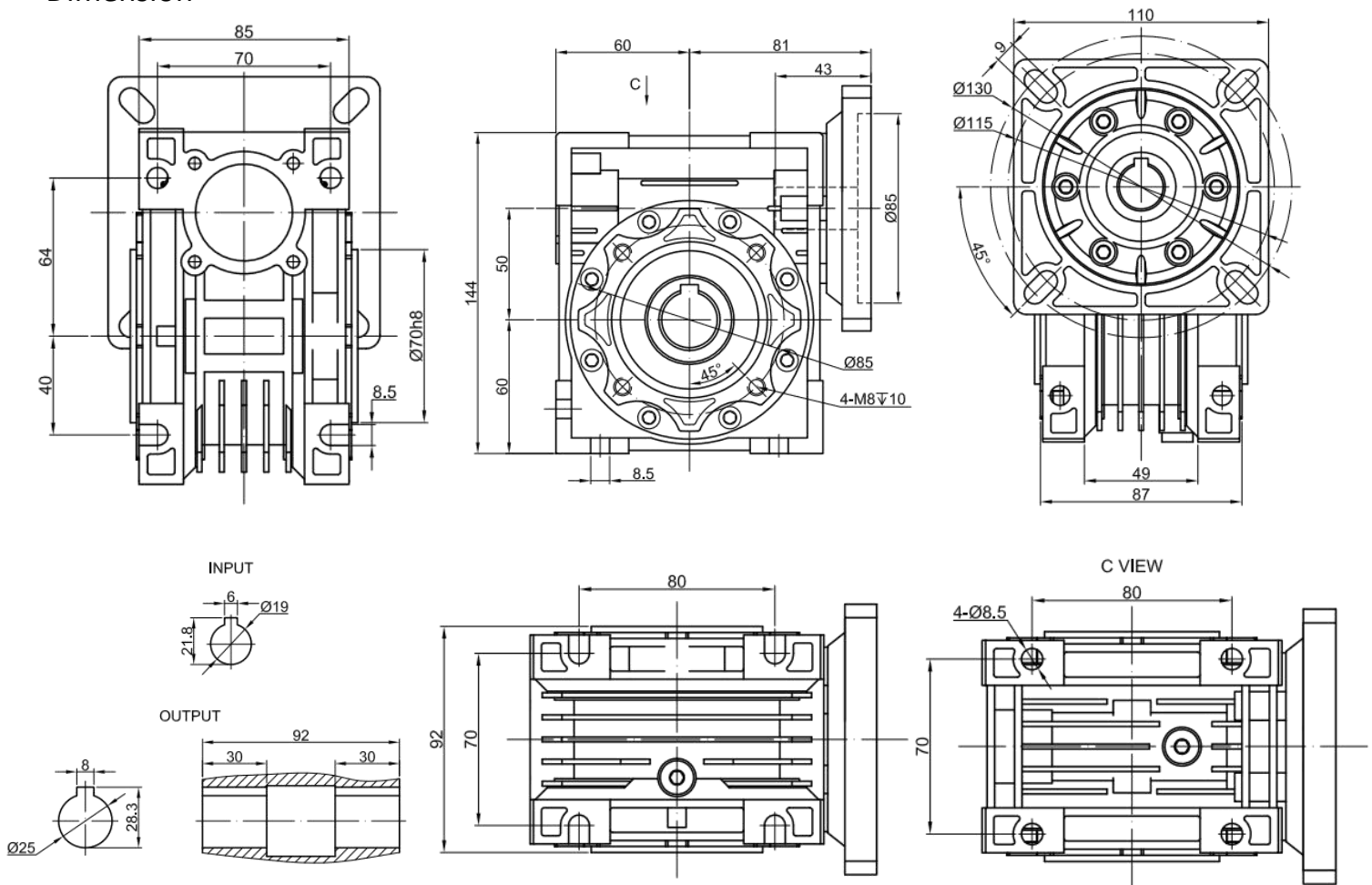

Output Shaft

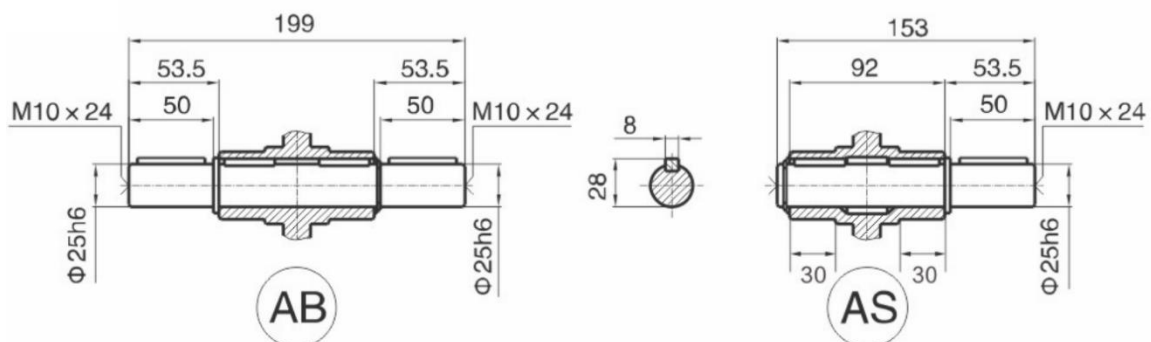



## Position of output shaft

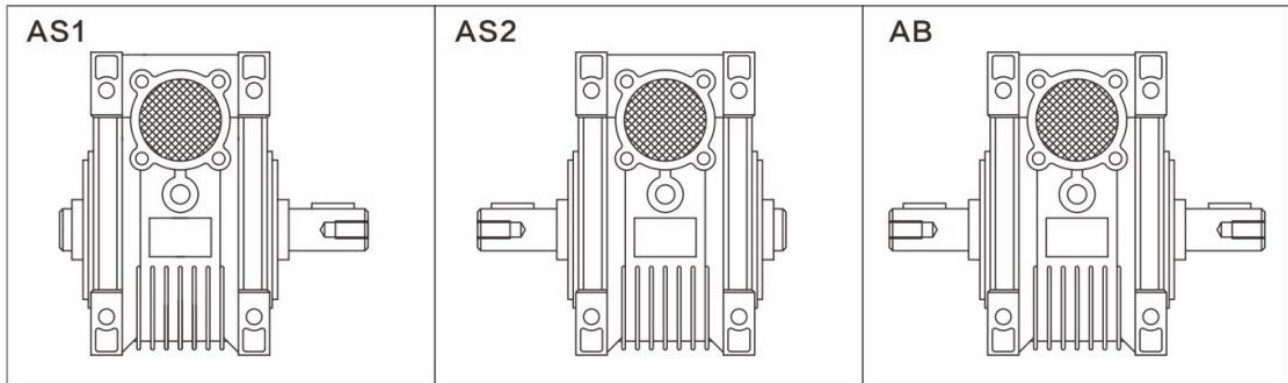

## Operating Instructions

### 1 Single-stage worm gear reducer

- 1.1 It adopts high quality aluminum alloy die-casting box. It has a beautiful appearance, compact structure, small volume, light weight, saving installation space, and not easy to rust and corrosion.
- 1.2 Good heat dissipation performance, safe and reliable, high efficiency.
- 1.3 High load capacity, smooth transmission, low vibration and low noise.
- 1.4 A variety connecting structures with power input and torque output to meet the needs of a variety of connections; box exterior design and the setting layout of the foot hole can adapt to a variety of installation methods, with strong versatility.

### 2 Installation precautions

- 2.1 The reducer must be installed on a flat and solid base, the foot bolt must be tight and anti-vibration.
- 2.2 The coupling shaft extension of the prime mover-reducer-working machine must be accurately aligned with each other's axis after installation.
- 2.3 The outer diameter tolerance of the reducer input end and output end shaft extension is made according to h6, and the matching couplings, pulleys, sprockets and other transmission parts need to be configured according to the appropriate tolerance size. In order to avoid assembly too tight to damage the bearings, avoid assembly too loose to affect the normal power transmission.
- 2.4 When shaft extension is installed on sprockets, gears and other transmission parts, it should be as close to the bearing as possible to reduce the bending stress of shaft extension.

### 3 Precautions for use

- 3.1 Before use, attention should be paid to check whether the reducer type structure, center distance specification, transmission ratio, input shaft connection, output shaft structure, axis pointing of input shaft output shaft and rotation direction are in line with the use requirements, and the worm input speed should not exceed 1500r/min.
- 3.2 When starting the machine, the load should be applied gradually and not start at full load.
- 3.3 The reducer is equipped with oil filling hole and oil drain hole, ISOVg320 lubricating oil has been added in the reducer at the factory, users do not need to refuel again. After 500 hours of continuous operation, the lubricant oil should be changed. After that, the oil change cycle is 6000 hours.

3.4 The maximum allowable oil temperature of the reducer is 85°C, and it should be stopped for inspection when it exceeds.

3.5 If the reducer has been placed for more than 4-6 months before use, while the oil seal is not immersed in lubricating oil, it is recommended to replace the oil seal.

3.6 If the use environment temperature of the reducer is more than or less than the use environment temperature specified in the table by more than 5°C, please contact our company personnel.

## Malfunctions Analysis

Fault Description	Reasons	Solutions
Overheating	Improper connection among prime mover, reducer and the operation device	Adjust to proper position
	Overloading	Adjust to proper load
	Over Friction of oil seals	Drop lubricant at oil seal
	Lubricant oil over much or shortage	Adjust to proper oil quantity as lubricant capacity table
	Much impurity in oil or inferior oil	Refill proper oil
Vibration	Prime mover, reducer and the operation device mount badly	Find out the bad place, tighten it
	Tooth surface of worm gear sets worm-out or damaged	Replace worm gear sets(we will cooperate with you when necessary)
	Bearing worn-out	Replace Bearing
	Bolt loose	Tighten Screw
Noise	Improper connection among prime mover, reducer and the operation device	Adjust to proper position
	Bearing damaged or too large clearance	Replace Bearing
	Worm gear sets mesh badly	Mend tooth surface or replace worm gear sets(please contact to us)
	Lubricant oil shortage	Fill in adequate oil as lubricant capacity table
Oil leakage	Oil seal lip worm- out	Replace oil seal
	Shalt of oil seal area worn-out	Replace input or output shall with worm gear
	Oil screw plug loose	Tighten oil screw plug
	Oil gauge damaged	Replace oil gauge
Tooth surface of worm gear sets abrade extra- quickly	Overload	Adjust to proper loading
	Lubricant oil not according with requirement	Replace proper lubricant oil
	Lubricant oil shortage	Fill adequate oil as indication
	Not replacing lubricant oil in time according to requirement, oil deteriorates	Replacing oil in time according to requirement
	Overheating while running	1. Deal with it as"Overheating" 2. Adopting proper measures to make environment temperature fall

Annotate:

1. Accored after the lubricant changed.
2. If other faults not listed above occur, Please contact with us at any moment, Our company will supply thorough consultation and service.